

Bureau's
HIGHER SECONDARY
PHYSICS
CLASS-XII

Prescribed by the Council of Higher Secondary Education, Odisha

Board of Writers

DR. N. N. PANIGRAHI

Director (Retd.)
Odisha State Bureau of Textbook Preparation
and Production, Bhubaneswar

MR. S. K. CHAKRABARTY

Reader in Physics (Retd.)
Ravenshaw Autonomous College
Cuttack

DR. N. K. RAO

Reader in Physics (Retd.)
V. Deb College, Jeypore

DR. S. C. MISHRA

Reader in Physics (Retd.)
N.C. College, Jajpur

DR. K. N. BISWAL

Principal, S. J. College (Retd.)
Naharakanta, Bhubaneswar

PROF. BHUBAN MOHAN SWAIN

Principal (Retd.)
Govt. College, Rourkela

SRI DEBASHISA MOHANTY

Lecturer in Physics
Model Degree College, Sonepur

Reviewer

PROF. (DR.) NIRANJAN BARIK

Prof. of Physics (Retd.)
Utkal University, Vanivihar
Bhubaneswar



Published by

Odisha State Bureau of Textbook Preparation and Production
Pustak Bhavan, Bhubaneswar

Bureau's

Higher Secondary Physics, Class-XII

(Prescribed by the Council of Higher Secondary Education, Odisha)

Published by :

The Odisha State Bureau of Textbook Preparation and Production,
Pustak Bhavan, Bhubaneswar, Odisha, India.

First Edition - 2004

Revised & Enlarged Edition - 2010/ 2000 copies

Revised Edition-2012/2000 copies

New Edition - 2017 / 5000 / 5000 Copies

Publication No. : OPT. 202

ISBN : 978 - 81 - 8005 - 396 - 2

© Reserved by the Odisha State Bureau of Textbook Preparation and Production, Bhubaneswar. No part of this publication may be reproduced in any form without the prior written permission of the publisher.

Type Setting, Designing : Sonali Prakashan, Bhubaneswar

Printing : Devi Graphics, Cuttack

Price : ₹ 220/- (Rupees Two hundred twenty only)

FOREWORD

(New Edition- 2017)

It is heartening to find that Bureau's Higher Secondary Physics (Class-XI & XII) are exhausted and very much appreciated by the students and teachers alike. This warm and positive response had led the Bureau to plan for a revised edition.

In the present edition, the books have been revised keeping in view the changes made in the CHSE Syllabus for Higher Secondary Students. This revision work was done by a team of experts consisting of Dr. Nikhilananda Panigrahi and Dr. Kedarnath Biswal. The untiring efforts made by these teachers-cum-writers of this book deserves our heartfelt thanks. I am very positive that this book will receive appreciation of the students as well as teachers. I am thankful to Dr. Kedarnath Biswal for taking pain of doing the arduous task of proof reading of both the books before final printing.

Improvement has no limit especially when one aims at excellence. Thus Bureau welcomes constructive suggestions from the students as well as teachers to make the book more purposeful.

Sri Umakanta Tripathy

DIRECTOR

Odisha State Bureau of Textbook Preparation and Production
Pustak Bhavan, Bhubaneswar

PREFACE

The "Bureau's Higher Secondary Physics" is intended to provide a proper motivation to the students and teachers at large in the study of physics. The basic concepts have been developed in a logical manner and utmost care has been taken to impart various nuances of physics with clarity of physical assumptions, mathematical formulation and approximations. Wherever necessary, better and appropriate alternative approaches have been adopted to overcome the conceptual inadequacies. S.I. units have been consistently used and whenever necessary C.G.S. and other useful practical units have been mentioned. Representative diagrams have been given to facilitate easy understanding. At the end of each section numerical examples have been worked out and at the end of each chapter model questions (multiple choice, very short answer, short answer, conceptual, unsolved numericals and long answer type) have been given to foster and boost the understanding and ability of readers for applying various concepts developed.

The authors are very much thankful to their colleagues and students for their valuable discussions, suggestions and advice. The authors can adequately express their gratitude to the Director Sri Umakanta Tripathy, Dy. Director Mr Biraja Bhusan Mohanty and all other personnels of "Odisha Textbook Bureau" for their constant support and encouragement. The authors are also thankful to Prof. (Dr.) N. Barik whose timely review and advice has streamlined the process of writing.

In spite of our sincere efforts typographical, conceptual, and factual errors might have crept in inadvertently. It is our sincere and humble request to all the readers to use the book with a receptive mind and point out our mistakes. Any suggestion for the improvement of the text book shall be highly appreciated with regards.

Authors

Syllabus [2016-2017]

Council of Higher Secondary Education, Odisha

PHYSICS THEORY

CLASS – XII

(Course to be covered in class XII , Higher Secondary Science of(2016-2017))

FULL MARK – 70 (160 Periods)

Unit-I Electrostatics (22 Periods)

1. Electric charges and fields: Electric charge and its quantization, conservation of charge, Coulomb's law, force between two point charges, force between multiple charges, superposition principle, Continuous charge distribution. **(See chapter – 1)**

Electric field due to a point charge, electric field lines, electric field due to a dipole at any point, torque on a dipole in uniform electric field.

Electric flux, Gauss's theorem (statement only) and its applications to find field due to uniformly charged infinite plane sheet, infinitely long straight wire and uniformly charged thin spherical shell (field inside and outside). **(See chapter – 2)**

2. Electrostatic potential and capacitance: Electric potential, potential difference, electric potential due to a point charge, potential due to a dipole, potential due to a system of charges. Equipotential surfaces, electrical potential energy of a system of two point charges and of electric dipole in an electrostatic field. **(See chapter – 2 & 3)**

Conductors, insulators, free charges and bound charges inside a conductor, Dielectrics and electric polarisation. **(See chapter – 2)**

Capacitors and capacitance, capacitance of a parallel plate capacitor with and without dielectric medium between the plates, combination of capacitors in series and in parallel, energy stored in a capacitor. **(See chapter – 3)**

Unit-II Current Electricity: (20 Periods)

Electric current, drift velocity, mobility and their relation with electric current, Ohm's law, electrical resistance, conductance, resistivity, conductivity, effect of temperature on resistance, V-I characteristics (linear and non-linear) electrical energy and power, carbon resistors, colour code of carbon resistors, combinations of resistors in series and parallel. **(See chapter – 5)**

EMF and potential difference, internal resistance of a cell, combination of cells in series and parallel, Kirchhoff's laws and simple applications: Wheatstone bridge and meter

bridge. Potentiometer- Principle and its applications to measure potential difference and for comparing EMF of two cells; measurement of internal resistance of a cell.

(See chapter – 6)

Unit-III Magnetic effect of Current and magnetism: (23 Periods)

1. Moving charges and magnetism: Concept of magnetic field, Oersted's experiment, Biot-Savart law and its application to find magnetic field on the axis and at the centre of a current carrying circular loop, Ampere's law and its application to infinitely long straight wire. Straight and toroidal solenoid (qualitative treatment only); Force on a moving charge in uniform magnetic and electric fields, (See chapter – 8) Cyclotron. (See chapter – 17)

Force on a current carrying conductor in a uniform magnetic field, force between two parallel current carrying conductors- definition of ampere, torque experienced by a current loop in uniform magnetic field, moving coil galvanometer- its current sensitivity and conversion to ammeter and voltmeter. (See chapter – 8)

2. Magnetism and matter: Current loop as a magnetic dipole and its magnetic dipole moment, magnetic dipole moment of a revolving electron, magnetic field intensity due to a magnetic dipole (bar magnet) along its axis and perpendicular to its axis, torque on a magnetic dipole (bar magnet) in a uniform magnetic field, bar magnet as an equivalent solenoid, magnetic field lines, earth's magnetic field and magnetic elements. (See chapter – 8)

Para-, dia- and ferro- magnetic substances with examples, Electromagnets and factors affecting their strengths, permanent magnets. (See chapter – 4)

Unit-IV Electromagnetic induction and Alternating current: (20 Periods)

1. Electromagnetic induction: Faraday's laws of electromagnetic induction, induced EMF and current, Lenz's law, Eddy currents, self and mutual induction. (See chapter – 9)
2. Alternating current: Alternating currents, peak and RMS value of alternating current/ voltage, reactance and impedance, LC oscillations (qualitative idea only), LCR series circuit, resonance, power in AC circuits, wattless current, A.C. generator and transformer. (See chapter – 10)

Unit- V Electromagnetic waves: (04 Periods)

Basic idea of displacement current, qualitative idea about characteristics of electromagnetic waves, their transverse nature. Electromagnetic spectrum (radio waves, microwaves, infrared, visible, X-ray and gamma rays), including elementary ideas about their uses. (See chapter – 14)

Unit-VI Optics**(25 Periods)**

1. Ray Optics and optical instruments: Reflection of light, spherical mirrors, mirror formula, lateral and longitudinal magnification, (See chapter – 11) refraction of light, refractive index, its relation with velocity of light (formula only) total internal reflection and its applications, optical fibre, Refraction at spherical surfaces, thin lens formula, lens makers formula, magnification, power of lenses, combination of two thin lenses in contact, combination of a lens and a mirror, refraction and dispersion of light through prism; Scattering of light: blue colour of sky and reddish appearance of sun at sunset and sunrise. (See chapter – 12)

Optical instruments: microscopes and telescopes (reflecting and refracting) and their magnifying powers. (See chapter – 13)

2. Wave Optics: Wave front, Huygen's principle, reflection and refraction of plane wave at a plane surface using wave fronts, proof of laws of reflection and refraction using Huygen's principle. Interference, Young's double slit experiment and expression for fringe width, coherent sources, sustained interference of light, diffraction due to a single slit, width of a central maximum, resolving power of microscope and astronomical telescope (qualitative idea) polarisation, plane polarised light, Brewster's law, uses of plane polarised light and polaroids. (See chapter – 14)

Unit-VII Dual nature of Radiation and matter:**(08 Periods)**

Dual nature of radiation, Photoelectric effect, Hertz and Lenard's observations, Einstein's photoelectric equation, particle nature of light.

Matter waves- wave nature of particles, de-Broglie relation, Davisson- Germer experiment, (only conclusions should be explained). (See chapter – 16)

Unit-VIII Atoms and Nuclei**(14 Periods)**

1. Atoms: Alpha-particle scattering experiment, Rutherford's model of atom, its limitations, Bohr model, energy levels, hydrogen spectrum. (See chapter – 16)
2. Nuclei: Atomic nucleus, its composition, size, nuclear mass, nature of nuclear force, mass defect, binding energy per nucleon and its variation with mass number, nuclear fission, fusion, Radioactivity, alpha, beta and gamma particles/ rays and their properties, radioactive decay law, half life and decay constant. (See chapter – 17)

Unit-IX Semiconductor electronics:**(10 Periods)**

Energy bands in conductors, semiconductors and insulators (qualitative idea only), p-type, n-type semiconductors, semiconductor diode, V-I characteristics in forward and reverse bias, diode as a half and full wave rectifier (centre tap), efficiency (no derivation). **(See chapter – 19)**

Special purpose p-n junction diodes: LED, photodiode, solar cell and Zener diode and their characteristics, Zener diode as a voltage regulator. **(See chapter – 19)**

Junction transistor, transistor action, Characteristics of a transistor, transistor as an amplifier (CE configuration), **(See chapter – 20)** basic idea of analog and digital signals, Logic gates (OR, AND, NOT, NAND, and NOR) **(See chapter – 22)**

Unit-X Communication System:**(10 Periods)**

Elements of a communication system (block diagram only), bandwidth of signals (speech, TV and digital data), bandwidth of transmission medium, propagation of electromagnetic waves in the atmosphere, sky and space wave propagation, satellite communication, Need for- modulation, qualitative idea about amplitude modulation and frequency modulation, advantages of frequency modulation over amplitude modulation, basic idea about internet, mobile telephony and global positioning system (GPS). **(See chapter – 21)**

CONTENTS

CHAPTER - 1

ELECTROSTATICS

1.0	Introduction	01
1.1	Electrostatics	01
1.2	Electric charge	01
1.3	Characteristics of electric charge	02
1.4	Unit of charge	03
1.5	Electrification	03
1.6	Point charge	05
1.7	Force between charged bodies	05
1.8	Coulomb's law and the force between two point charges	05
1.9	Coulomb's law and units of charge	06
1.10	Effect of medium on Coulomb interaction	07
1.11	Dimensions of permittivity	08
1.12	Principle of superposition of coulomb's forces	08
1.13	Force on a charge due to a multiple electric charges	08
1.14	Salient features of coulomb interaction	10
1.15	Continuous charge distribution	11
	MODEL QUESTIONS	16

CHAPTER - 2

ELECTRIC FIELD AND POTENTIAL

2.1	Electric field	22
2.2	Electric field intensity or electric field strength	22
2.3	Electric field intensity due to point charge	23
2.4	Electric field intensity due to a group of discrete charges	23
2.5	Electric field intensity due to a continuous charge distribution	24
2.6	Lines of force	24
2.7	Properties of electric lines of force	25
2.8	Electric dipole	25
2.9	Electric field due to an electric dipole	26
2.10	Electric dipole in a uniform electric field	31
2.11	Work done in rotating an electric dipole in a uniform electric field	31
2.12	Electric potential energy of an electric dipole in an electric field	31
2.13	Electric flux	32
2.14	Gauss's law and its proof	32
2.15	Gaussian surface	34
2.16	Applications of Gauss's law	34
2.17	Conservative nature of electric field	37
2.18	Electric potential energy	38
2.19	Electrostatic potential	39

2.20	Potential difference	39
2.21	Zero reference potential	39
2.22	Units of electric potential (V) and relation between them	40
2.23	Dimensions of electric potential	40
2.24	Electron volt	40
2.25	Electric potential due to a point charge	41
2.26	Principle of superposition of potentials	41
2.27	Potential due to a system of charges	41
2.28	Electrostatic potential due to an electric dipole	42
2.29	Conductor, Insulator and Dielectrics	43
2.30	Potential of a charged conductor	46
2.31	Electric potential energy of a group of point charges	47
2.32	Relation between electric field intensity and potential gradient	49
2.33	Equipotential lines and surfaces	50
	MODEL QUESTIONS	59

CHAPTER - 3

CAPACITANCE

3.1	Capacitor	68
3.2	Simple capacitor	68
3.3	Capacitance	68
3.4	Units of capacitance	69
3.5	Dimensions of capacitance	69
3.6	Capacitance of an isolated spherical conductor	69
3.7	Capacitance of a parallel plate capacitor	70
3.8	Parallel plate capacitor partly filled with a dielectric	71
3.9	Dielectric and its effects	72
3.10	Dielectric strength	74
3.11	Combinations of capacitors	74
3.12	Distinction between series and parallel combination of capacitors	76
3.13	Electrostatic potential energy stored in a charged capacitor	77
3.14	Energy density of an electric field	78
3.15	Force of attraction between two plates of a charged parallel plate capacitor	78
3.16	Capacitance of a spherical capacitor	79
3.17	Types of capacitors	81
	MODEL QUESTIONS	87

CHAPTER - 4

MAGNETOSTATICS

4.1	Magnets	93
4.2	Properties of a magnet	93
4.3	Bar magnet	94

4.4	Magnetic dipole	94
4.5	Magnetic field	94
4.6	Magnetic lines of force	95
4.7	Properties of magnetic lines of force	95
4.8	Coulomb's law of magnetism	95
4.9	Coulomb's law in different system of units	96
4.10	Magnetic induction	97
4.11	Magnetic induction or magnetic field due to an isolated magnetic pole	97
4.12	Magnetic intensity or magnetising field	98
4.13	Magnetic potential	98
4.14	Magnetic induction or magnetic field due to a bar magnet	99
4.15	Torque experienced by a bar magnet or magnetic dipole in a uniform magnetic field	102
4.16	Work done in rotating a bar magnet in a uniform magnetic field	103
4.17	Terrestrial magnetism	104
4.18	Some terms connected with geomagnetism	104
4.19	Magnetic elements of earth	105
4.20	Apparent dip	106
4.21	Neutral point	107
4.22	Magnetic properties of materials	108
4.23	Intensity of magnetization (I)	108
4.24	Magnetic intensity or Magnetizing field intensity \vec{H}	109
4.25	Magnetic induction or magnetic flux density \vec{B}	109
4.26	Magnetic susceptibility (χ)	110
4.27	Permeability	110
4.28	Curie's law	111
4.29	Classification of Magnetic Materials	111
4.30	Dimagnetic substances	111
4.31	Paramagnetic substances	113
4.32	Ferromagnetic substances	114
4.33	Hysteresis	115
4.34	Soft iron and steel	116
4.35	Tangent law	116
	MODEL QUESTIONS	124

CHAPTER - 5

ELECTRIC CURRENT

5.1	Electric current	132
5.2	The current density vector \vec{J}	135
5.3	Drift velocity of electrons in a conductor	136
5.4	Relation between \vec{J} and \vec{E} , Ohm's law	137
5.5	Resistance and Resistivity	139
5.6	Variation of Resistance and Resistivity with temperature	141
5.7	Resistors	143
	MODEL QUESTIONS	151

CHAPTER - 6

DIRECT CURRENT CIRCUITS

6.1	Electromotive force	158
6.2	The sources of e.m.f.	161
6.3	Electrical Circuit accessories	166
6.4	Grouping of resistors and cells	168
6.5	Grouping of cells	170
6.6	Kirchhoff's laws and their application to any network	173
6.7	Potentiometer	178
	MODEL QUESTIONS	185

CHAPTER - 7

THERMAL AND CHEMICAL EFFECTS OF ELECTRIC CURRENT

7.1	Electric energy and power	193
7.2	Heating effect of electric current	196
7.3	Heating effect in different conductors	198
7.4	Chemical effect of electric current, electrolysis	200
7.5	Faraday's laws of electrolysis	201
7.6	Some applications of electrolysis	203
	MODEL QUESTIONS	208

CHAPTER - 8

MAGNETIC EFFECT OF ELECTRIC CURRENT

8.1	Introduction	215
8.2	The magnetic field and magnetic induction	216
8.3	Magnetic flux	218
8.4	Biot - Savart law	219
8.5	Magnetic field due to a straight current	221
8.6	a) Magnetic field at the centre of a circular coil carrying current	223
	b) Magnetic field at any point on the axis of a circular coil carrying current	224
8.7	Magnetic dipole moment of the coil and B' due to it	226
8.8	Magnetic dipole moment of revolving electron	228
8.9	Magnetic field at any point on the axis of a solenoid	229
8.10	Bar magnet as an equivalent solenoid	230
8.11	Ampere's Circular Law	231
8.12	The Lorentz force	233
8.13	Motion of a charged particle in a uniform magnetic field	234

8.14	Magnetic force on a current carrying conductor	236
8.15	Torque on a current loop in a uniform magnetic field	239
8.16	The moving coil galvanometer	240
8.17	Conversion of galvanometer to ammeter	244
8.18	Conversion of galvanometer to voltmeter	245
	MODEL QUESTIONS	255

CHAPTER - 9 ELECTROMAGNETIC INDUCTION

9.1	Electromagnetic induction	266
9.2	Faraday's law of electromagnetic induction	268
9.3	Lenz's law	269
9.4	Motional emf	271
9.5	Induced electric field	274
9.6	Eddy current	275
9.7	Self induction	276
9.8	Mutual induction	279
9.9	E.m.f. induced in a rotating coil	282
	MODEL QUESTIONS	291

CHAPTER - 10 ALTERNATING CURRENTS

10.1	Alternating current	299
10.2	Average and effective values of alternating current	300
10.3	Simple a.c. circuits	303
10.4	More about a.c. circuit	311
10.5	Simple a.c. devices	318
10.6	Transformer	319
10.7	LC Oscillatrons	322
	MODEL QUESTIONS	330

CHAPTER - 11 REFLECTION AND SPHERICAL MIRROR

11.1	Light preliminaries	338
11.2	Spherical mirror	339
11.3	Procedure for object-image ray diagram : Spherical mirrors	341
11.4	Relation between focal length and Radius of curvature	342
11.5	Sign Convention : Spherical mirrors	343
11.6	u-v relation for spherical mirrors	343

11.7	Magnification	346
11.8	Nature, Position and Size of image	346
11.9	Summary of results	348
11.10	Conjugate points	349
11.11	Identification of mirrors	349
11.12	Uses of spherical mirrors	349
11.13	Spherical aberration	349
11.14	Hints for solving numerical problems	349
	MODEL QUESTIONS	353

CHAPTER - 12

REFRACTION, DISPERSION AND LENS

12.1	Refraction : Real depth and apparent depth	357
12.2	Total internal Reflection	359
12.3	Conditions for total internal reflection	360
12.4	Optical Fibre	360
12.5	Prism : Preliminaries	363
12.6	Refraction through prism	363
12.7	Deviation produced by a prism of small angle : Thin Prism	364
12.8	Application of total internal reflection to prism	365
12.9	Dispersion	366
12.10	Spectrum	366
12.11	Arrangement for pure spectrum	367
12.12	Classification of spectra	367
12.13	Dispersive power	368
12.14	Refraction at curved surface	368
12.15	Power : Spherical refracting surface	370
12.16	Refraction through a lens bounded	371
12.17	Lenses : Preliminaries	372
12.18	Graphical construction of image for lenses	374
12.19	Sign convention : Lenses	374
12.20	General formula for lenses	374
12.21	Magnification (=m)	376
12.22	Nature, size, position of image	376
12.23	Summary of results	378
12.24	Power of lens (P)	379
12.25	Diopetre	379
12.26	Power of two lenses in contact	379
12.27	Identification of lenses	379
12.28	Scattering of light	379
	MODEL QUESTIONS	389

CHAPTER - 13
EYE AND OPTICAL INSTRUMENTS

13.1	Eye	396
13.2	Power of accommodation	397
13.3	Persistence of vision	397
13.4	Far-point of the eye	397
13.5	Near-point of the eye	397
13.6	Defects of vision	397
13.7	Optical instruments	399
13.8	Microscope	400
13.9	Astronomical Telescope	404
	MODEL QUESTIONS	411

CHAPTER - 14
WAVE OPTICS AND INTERFERENCE

14.1	Theories of light	418
14.2	Huygen's wave theory	418
14.3	Wave front and ray	420
14.4	Success of wave theory	420
14.5	Application of wave theory	420
14.6	Interference	422
14.7	Coherent sources	422
14.8	Young's double slit experiment	422
14.9	Fringe width	425
14.10	Conditions for interference	426
14.11	Diffraction	430
14.11(a)	Faundhofer diffraction by a single slit	430
14.12	Revolving Power	433
14.13	Polarisation	435
14.14	Electromagnetic spectrum	438
	MODEL QUESTIONS	444

CHAPTER - 15
RELATIVITY

15.1	Some important terms and definitions	451
15.2	Classical Principle of relativity	452
15.3	Consequences of Galilean relativity	452
15.4	Michelson-Morley experiment (1881)	453
15.5	Einstein's special theory of Relativity	456
15.6	Lorentz transformation equations	457
15.7	Simultaneity	458

15.8	Lorentz (Fitzgeral) contraction	459
15.9	Time-dilation	460
15.10	Variation of mass and momentum with velocity	461
15.11	Expression for force	462
15.12	Mass-energy relation	463
15.13	Momentum of a photon	464
	MODEL QUESTIONS	470

CHAPTER - 16 ATOMIC PHYSICS

16.1	Atomic models	475
16.2	Alfa particles scattering experiment	475
16.3	Rutherford's model of the atom	477
16.4	Limitations of Rutherford's Atomic model	477
16.5	Bohr's model of atom (1913)	478
16.6	Bohr's theory of hydrogen atom	478
16.7	Origin of spectral lines	481
16.8	Some terms associated with hydrogen spectrum	484
16.9	Limitations of Bohr's atomic model	485
16.10	Photoelectric effect, Threshold frequency	485
16.11	Einstein's photo electric equation (1905) work function	486
16.12	Experimental study of photo-electric emission	487
16.13	Verification of Einstein's photo-electric equation	488
16.14	Photo-electric cell	490
16.15	Uses of photocells	491
16.16	Dual nature of light	491
16.17	Wave nature of matter De Broglie relations	492
16.18	Davission Germer Experiment	493
16.19	X-Rays	495
16.20	Bragg's law	497
16.21	Spectrum of X-rays	497
16.22	Moseley's law	498
16.23	Continuous x-rays	499
	MODEL QUESTIONS	506

CHAPTER - 17 NUCLEAR PHYSICS

17.1	Structure of nucleus	523
17.2	Size of nucleus	524
17.3	Nuclear dencity	524
17.4	Nuclear angular momentum and magnetic moment	524

17.5	Mass	524
17.6	Nuclear force	524
17.7	Isotope, Isotone, Isobar, Isomer and Mirror Nuclide	526
17.8	Mass-Energy conservation and nuclear energy : Mass-defect	526
17.9	Packing fraction	527
17.10	Binding energy	527
17.11	Biding energy per nucleon	528
17.12	Binding energy curve	528
17.13	Nuclear reaction	529
	a) Laws Governing Nuclear reaction	530
	b) Energetics of nuclear reaction	531
	c) Cross-section	532
	d) Discovery of Neutron	532
17.14	Nuclear Fission	534
17.15	Nuclear fusion	541
17.16	Radio activity	542
17.17	Cyclotron	552
	MODEL QUESTIONS	556

CHAPTER - 18

ELECTRON EMISSION

18.1	Electron emission	564
18.2	Type of electron emission	564
18.3	Richardson-Dushman equation	565
18.4	Thermoionic emitter	565
18.5	Vacuum tubes	566
18.6	Vacuum diode	566
18.7	Characteristics of vacuum diode	568
18.8	Plate resistance of a diode	569
18.9	Vacuum Triode	569
18.10	Characteristics of a triode	570
18.11	Static characteristics of a triode	571
18.12	Triode constants or parameters	573
18.13	Relation between the triode parameters	574
18.14	Determination of triode constants from its characteristics	575
18.15	Triode as an amplifier	576
18.16	Distinction between a triode and a step up transformer	578
18.17	Vacuum diode as a rectifier	578
	MODEL QUESTIONS	586

CHAPTER - 19 SOLIDS

19.1	Structure of solids	592
19.2	Binding in solids	592
19.3	Ionic or heteropolar bond	593
19.4	Covalent bond	593
19.5	Metallic bond	594
19.6	Van der Waals bond or molecular bond	594
19.7	Energy bands in solids	594
19.8	Classification of solids on the basis of band theory	596
19.9	Types of semiconductors	597
19.10	Types of Extrinsic semiconductors	598
19.11	Effect of temperature on extrinsic semiconductor	600
19.12	Electrical conductivity in semiconductors	601
19.13	Currents in semiconductors	601
19.14	P-n junction	602
19.15	Function of a p-n junction	602
19.16	P-n junction diode	603
19.17	Volt-amp characteristic of a p-n junction	604
19.18	Crystal diode versus vacuum diode	605
19.19	P-n junction as a rectifier	605
19.20	Ripple factor	608
19.21	Special purpose p-n junction diode	609
	MODEL QUESTIONS	622

CHAPTER - 20 TRANSISTORS

20.1	Junction transistor	630
20.2	Biasing of a transistor	631
20.3	Working of an n-p-n transistor	631
20.4	Working of a p-n-p transistor	631
20.5	Modes of operation of a transistor	632
20.6	A.C. current gains or Transistor parameters	632
20.7	Relation between transistor parameters	632
20.8	Transistor characteristics	633
20.9	Common base (CB) characteristics of a transistor	633
20.10	Common emitter (CE) characteristics of a transistor	635
20.11	Transistor as an amplifier	636
20.12(a)	Common base amplifier	636
20.12(b)	Common emitter amplifier	637
20.13	Comparison between CB and CE amplifiers	638
20.14	Advantages of a Transistor over a triode	638
	MODEL QUESTIONS	641

CHAPTER - 21 SPACE COMMUNICATION

21.1	Electromagnetic Wave	648
21.2	Hertzian-dipole	648
21.3	Radiation due to an oscillating dipole	649
21.4	Radiation due to a small current	650
21.5	Linear half-wave antenna	650
21.6	Electromagnetic spectrum	650
21.7	Properties of e.m. waves	651
21.8	Need for modulation	651
21.9	Modulation	651
	a) Types of modulation	651
21.10	Amplitude modulation (AM)	652
21.11	Frequency modulation (FM)	657
21.12	Phase modulation (PM)	660
21.13	Demodulation	661
21.14	Space communication	662
21.15	Satellite Communication	665
	MODEL QUESTIONS	669

CHAPTER - 22 DIGITAL ELECTRONICS

22.1	Introduction	674
22.2	Analog Signal	674
22.3	Digital Signal	675
22.4	Number system	677
22.5	Conversion of a number from one system to another system	678
22.6	Binary arithmetic operation	678
22.7	Disadvantages of binary system	681
22.8	Logic	681
22.8(i)	Gate	681
22.8(ii)	Logic gate	681
22.8(iii)	Types of logic gate	681
	MODEL QUESTIONS	694

1

Electrostatics

1.0 Introduction :

Physics is a rapidly advancing branch of science. Physicists are making consistent efforts to unravel the various forces that control the universe and unify them; and to explain how these forces manifest spontaneously in different forms at different energy levels. During this quest several predictions are made. One such prediction, the existence of "higg's bosons", predicted by Peter Higgs, has been very recently confirmed by the ATLAS and CMS experiments in Large hadron Collider at CERN by our eminent experimentalists. Thus when Physics is leaping to such heights so rapidly, our curriculum for students in Physics needs to be prepared to catch up with the advancement of Physics within a time frame. Keeping this in view, our academicians very carefully and thoughtfully prepare syllabus making a conscious compromise between the level of studies and the level of knowledge the students need to arrive at. In this regard the authors of text books and teachers teaching in the class room need to bear a greater responsibility. The authors should try to present materials so that it is comprehensive and up to the desired standard. The teachers should impart these materials to the students so that they grasp the materials properly and rightfully. Keeping in view these aspects this book has been revised with due care and sincerity.

1.1 Electrostatics :

The branch of physics which deals with the properties of electricity at rest i.e. stationary charge is called electrostatics or statical electricity.

Stationary charge can be produced in insulating substances like amber, ebonite, glass etc. rubbing with fur, silk cloth etc.

The important properties that are dealt with electrostatics are electric charge, electric field, electric potential, dielectric polarization, capacitance etc. While electrostatic studies usually concentrate on electricity at rest, it should be noted that some of the electrostatic properties of electric charges also exist when the charges are in motion.

Electric charges can be stored in devices called cells and capacitors. In a capacitor electric charges can be removed and replaced within a millionth of a second giving rise to a large number of applications in the radio, television, radar and communication industries etc.

1.2 Electric Charge :

The force of attraction between any two material bodies is gravitational in nature. Between an electron and a proton, besides gravitational force of attraction, there exists a much more stronger force of attraction, known as electric force. The electric force can be attractive or repulsive.

Material particles, like electrons, protons etc. which have an additional property, (apart from their masses) responsible for electrical forces are called charged particles. The charges cause electric field i.e. *the source of electric field is known as electric charge*. A material body can accept electrons or lose electrons. *A material body having an excess of electrons or a deficit in the number of electrons compared to the neutral body is called a charged body*. It is not possible to describe the charge in terms of simpler concepts like shape, colour, fluidity etc. It is best understood not by saying what it is, but what it does.

1.3 Characteristics of electric charge :

i) Two kinds of electric charge

The electric force between two electrons a distance apart is found to be repulsive and same as that due to two protons placed at the same distance of separation. However, if a proton and an electron are placed at the same distance of separation as above, the electric force between them is found to be same in magnitude but attractive. It suggests that the nature of charge in electron and proton is different but same in magnitude.

William Gilbert first gave the idea of electric charge. He derived the word electron from Greek meaning amber which has a strong charge acquiring property when rubbed with other substances like fur etc. Du Fay showed that there are two kinds of charge. Benjamin Franklin arbitrarily chose the charge of an electron as negative and that of a proton as positive. These assigned signs to charges greatly helped in the concise mathematical formulations of experimental facts such as *like charges repel and unlike charges attract*.

ii) Quantum nature of charge

Millikan's experiments showed that, in nature, electric charge exists in discrete packets rather than in continuous fashion. One packet

of charge is the basic charge and is equal to that of an electron having magnitude $e = 1.60218 \times 10^{-19}$ Coulomb. Fractional basic charge does not exist in nature. All the existing charges are integral multiples of this basic charge. Thus any physically existing charge Q can be expressed as ne i.e. $Q = ne$ where n is a positive or a negative integer. Charge is thus quantized. One quantum of charge, in magnitude, is that of an electron or proton. An α -particle has two quanta of positive charge.

Example 1.3.1 In Millikan's oil drop experiment, the charges on four different drops were found to be $1 \times 1.6 \times 10^{-19}$ Coul, $2 \times 1.6 \times 10^{-19}$ Coul, $5 \times 1.6 \times 10^{-19}$ Coul and $7 \times 1.6 \times 10^{-19}$ Coul. What do you infer from these results ?

Solution :

The given charges on the four drops are

$$q_1 = 1 \times 1.6 \times 10^{-19} \text{ Coul}$$

$$q_2 = 2 \times 1.6 \times 10^{-19} \text{ Coul}$$

$$q_3 = 5 \times 1.6 \times 10^{-19} \text{ Coul}$$

$$q_4 = 7 \times 1.6 \times 10^{-19} \text{ Coul}$$

The H.C.F. of the above charges is 1.6×10^{-19} Coul. This is the minimum possible charge. Therefore, basic charge is 1.6×10^{-19} Coul. All other charges are integral multiples of the basic charge. From the results we infer that (i) charge is quantized and (ii) one quantum of charge is 1.6×10^{-19} Coul.

iii) Conservation of charge

Net charge can neither be created nor destroyed. Net charge of this universe always remains constant. If a positive charge is produced, an equal amount of negative charge is also formed simultaneously so that net charge created in a process is zero. Consider, for example, the process of charging an amber rod

by rubbing with fur. Before rubbing they have no net charge. After rubbing, amber gets negatively charged while fur gets positively charged. These charges are produced due to transfer of electrons from fur to amber. Hence magnitude of charge in amber and fur is same but opposite in nature. Net combined charge in them is zero before and after rubbing. Let us consider another example : when a neutron decays, it does so into a proton, an electron and a neutral particle called antineutrino. Hence the net charge before and after the decay of a neutron is zero.

It is clear that there is a law conserving electric charge and no exceptions have been discovered so far. *The law of conservation of charge states that the algebraic sum of the electric charges in any closed system remains constant.*

iv) **Scalar nature of charge :**

Charges are added algebraically. If a body is given a positive charge Q_1 and a negative charge Q_2 , the total charge acquired by the body is $Q = Q_1 - Q_2$.

v) **Invariance of Charge :**

Einstein established that space, time and matter are relative. It means, their values vary and depend on the state of motion of the observer relative to them. But charge is relativistically invariant i.e. the value of a charge does not depend on relative motion between the charge and the observer.

$$Q_{\text{rest}} = Q_{\text{motion}}$$

1.4 Unit of Charge :

S.I. unit of charge is Coulomb, abbreviated as C. The charge on proton is $e = 1.60218 \times 10^{-19} \text{ C}$ and it is approximately written as $1.6 \times 10^{-19} \text{ C}$. The charge on electron is $-e$.

Coulomb :

The Coulomb is defined as the amount of charge that flows through the cross-section of a conductor in one second if there is a steady current of one ampere in it.

Example 1.4.1 What is the charge of a body, if it has a deficit of 2.5×10^{13} electrons over its neutral state.

Solution :

$$\begin{aligned} &\text{Charge of deficit of one electron in a body} \\ &= 1.6 \times 10^{-19} \text{ C} \end{aligned}$$

$$\begin{aligned} &\text{Charge deficit of } 2.5 \times 10^{13} \text{ electrons} \\ &= + 1.6 \times 10^{-19} \text{ C} \times 2.5 \times 10^{13} \\ &= 4.0 \text{ } \mu\text{C} \end{aligned}$$

1.5 Electrification :

The process of charging an uncharged body is called electrification. It can be achieved by the following three processes :

- i) By friction
 - ii) By conduction and
 - iii) By induction.
- i) **Electrification by friction or frictional electricity :**

As early as 600 B.C., Greeks knew that amber can be electrically charged by rubbing with fur. It is our common experience that a comb rubbed against dry hair becomes charged and can attract small pieces of paper. An automobile becomes charged when it travels through air.

The charge i.e. electricity produced in a body by rubbing with another body is called frictional electricity.

The explanation of production of frictional electricity is very simple. All material bodies in

their normal state are electrically neutral, containing equal number of protons and electrons. When one body is rubbed with another, some of the atomic electrons of one body go to the other. Thus, while the one loses electrons becomes positively charged, the other having an excess of them becomes negatively charged. As an example, let us consider a glass rod rubbed with a silk cloth. Some electrons from the glass rod are transferred to the silk cloth. The glass rod, having a deficit in the number of electrons, is positively charged while the silk cloth, having excess of electrons, is negatively charged.

Some of the substances have been arranged in a list (Table 1.1) such that when any two of those are rubbed together, the one occurring in the list earlier will be positively charged and the one occurring later will be negatively charged.

Table 1.1

1. Fur	2. Flannel	3. Glass
4. Mica	5. Catskin	6. Silk
7. Cotton	8. wood	9. Human body
10. Amber	11. Resin	12. Sulphur
13. Ebonite	14. Celluloid	

ii) Electification by Induction :

Consider a positively charged glass rod **G** brought near an insulated uncharged conductor as shown in the fig. (1.1).

Some of the free electrons of the conductor are attracted by the positive charge of the glass rod

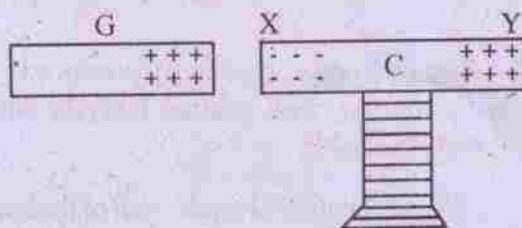

Fig. 1.1

thereby accumulating negative charge at the end **X**, nearer the glass rod, leaving a deficiency of electrons and producing a positive charge at the far end **Y**, of the conductor.

The process of accumulation of positive and negative charges at the two ends of an uncharged conductor when a charged body is brought near it is called electro-static induction.

This way of producing charges in a conductor is temporary because, if the glass rod is taken away from the conductor, the positive and negative charges accumulated at the two ends of the conductor redistribute themselves throughout the conductor and disappear.

However, a conductor can be charged positively or negatively by induction as follows :

Consider two uncharged metal spheres, supported on two insulating stands, touching each other as shown in the fig. 1.2(a).

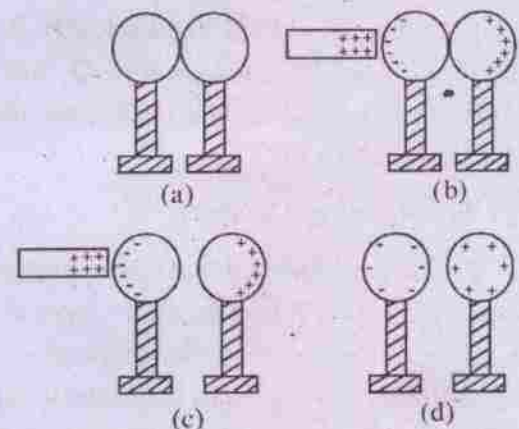

Fig. 1.2

When a positively charged glass rod is brought near one of the spheres but without touching it (Fig. 1.2.b), the free electrons of the metal sphere are attracted towards the positive charge of the rod, thereby accumulating negative charge on the left surface of the left sphere. This leaves a deficiency of electrons on the right surface of the right sphere, producing a positive charge there. Now, in the presence of charged rod, the charged spheres are separated from each

other (Fig. 1.2c). When the charged rod is taken away and the two spheres are well separated, the left sphere acquires negative charge while right sphere acquires positive charge (Fig. 1.2.d)

iii) *Electrification by conduction :*

When a charged conductor is kept in contact with an uncharged conductor, it acquires some charge from the former. Both of the conductors will have same type of charge but amount of charge on each conductor depends on their sizes and shapes.

The process of acquiring a similar charge by an uncharged conductor from a charged conductor, when they are in contact with each other, is called electrification by conduction.

1.6 Point Charge :

From a physical point of view, any charged body, having dimensions very small in comparison with its distance from a point where its effects are studied, is considered as a point charge. Thus even a charged body of dimensions as large as the earth can be considered as a point charge if its electrical effects at a point as far as the sun are considered.

1.7 Force between charged bodies :

Consider two charged bodies. The electrical interaction between them results in a mutual force i.e., each charge exert a force on the other. It is one of the fundamental forces between two charges similar to gravitational force between masses of the two bodies. One cannot think of a charge without mass. The force between two charged bodies is two-fold. One is gravitational force of attraction and the other is electrostatic force. The latter is much stronger than the former. The ratio of their strength is of the order of 10^{42} for a pair of electrons.

In 1784, French physicist, Charles Augustin de Coulomb, basing on experiments, was the first to estimate quantitatively, the force between two charged bodies. The electrical force between two charged bodies is often referred as Coulomb force.

1.8 Coulomb's law and the force between two point charges :

Coulomb's law states that the force of attraction or repulsion between two point charges at rest is directly proportional to the product of the two charges and inversely proportional to the square of the distance between them.

Let F be the coulomb force between two point charges Q_1 and Q_2 separated by a distance r . Then

$$F \propto Q_1 Q_2$$

$$\propto \frac{1}{r^2}$$

$$F = K \frac{Q_1 Q_2}{r^2} \quad \dots 1.8.1(a)$$

where K is a constant of proportionality. This constant K is a dimensional quantity and its value depends on the system of units and property of the medium. In empty space

$$F = K_0 \frac{Q_1 Q_2}{r^2} \quad \dots 1.8.1$$

Equation (1.8.1) gives us only the magnitude of the force of interaction between the two point charges.

Force being a vector quantity, the direction of force on each charge is determined taking the following into account.

- i) the direction of the force on each charge is always along the line joining the two charges.
- and ii) the force on each charge is repulsive
 - if the two charges are similar and attractive
 - if the two charges are dissimilar.

Coulomb's law in vector form is

$$\vec{F} = K_0 \frac{Q_1 Q_2}{r^2} \hat{r} \quad \dots 1.8.2$$

$$= K_0 \frac{Q_1 Q_2}{r^3} \vec{r} \quad \dots 1.8.3$$

where \vec{r} is the position vector of charge which experiences the force with respect to the charge which exerts the force (fig.1.3). \hat{r} is the unit vector of \vec{r} .

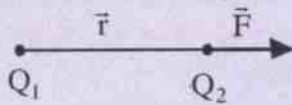

Fig.1.3

An alternative form, which incorporates attractive and repulsive nature of charge is

$$\vec{F}_{12} = K_0 \frac{Q_1 Q_2}{|\vec{r}_{12}|^3} \vec{r}_{12} \quad \dots 1.8.3(a)$$

Where \vec{r}_{12} is the vector directed from Q_1 to Q_2 , \vec{F}_{12} is the force exerted by charge Q_1 on Q_2 (see fig 1.3 (a))

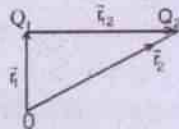

Fig.1.3(a)

1.9 Coulomb's law and units of charge :

Eqn. (1.8.1) expressing coulomb's law is the basis for defining unit of charge in different systems of units.

i) C.G.S electrostatic system (e.s.u) of unit of charge

In cgs (esu) K_0 is set equal to unity.

Recollecting eqn. (1.8.1)

$$F = K_0 \frac{Q_1 Q_2}{r^2}$$

and putting $r = 1 \text{ cm}$, $K_0 = 1$

$$F = 1 \text{ dyne}, Q_1 = Q_2 = Q \text{ (say)}$$

We have $Q^2 = 1$ or $Q = \pm 1$ statcoul.

Statcoulomb is the cgs-esu of charge which repels an identical charge in vacuum at a distance of one centimeter with a force of one dyne.

Charge of a proton is 4.8×10^{-10} statcoulomb.

In cgs-esu, mathematically, Coulomb's law can be expressed in a simple form in free space as

$$F = \frac{Q_1 Q_2}{r^2} \quad \dots 1.9.1$$

ii) S.I. system of unit of charge

In S.I. system, since F , Q and r - all are independently predefined quantities, the constant K_0 has to be determined experimentally so as to fit into the Coulomb's law. The measured value of K_0 is found to be $8.98755 \times 10^9 \text{ Nm}^2 \text{ C}^{-2}$ ($\approx 9 \times 10^9 \text{ Nm}^2 \text{ C}^{-2}$).

Let us now define unit of charge-Coulomb from Coulomb's law

$$F = K_0 \frac{Q_1 Q_2}{r^2}$$

If $Q_1 = Q_2 = 1 \text{ C}$, $r = 1 \text{ m}$

then $F = K_0 = 9 \times 10^9 \text{ N}$

Thus one Coulomb of charge is defined as that amount of charge which when placed in vacuum at a distance of one meter from an identical charge repels it with a force of 9×10^9 Newton.

In electrostatics it is found that most of the results derived using Coulomb's law contain a factor 4π . To avoid the factor 4π , a new constant ϵ_0 is introduced by the relation

$$K_0 = \frac{1}{4\pi \epsilon_0}$$

so that the eqn. (1.8.1) becomes

$$F = \frac{1}{4\pi \epsilon_0} \frac{Q_1 Q_2}{r^2} \quad \dots 1.9.2$$

The constant ϵ_0 is known as permittivity of free space and its value is

$$\begin{aligned} \epsilon_0 &= \frac{1}{4\pi K_0} = 8.85419 \times 10^{-12} \text{ C}^2 \text{ N}^{-1} \text{ m}^{-2} \\ &\approx 8.85 \times 10^{-12} \text{ C}^2 \text{ N}^{-1} \text{ m}^{-2}. \end{aligned}$$

Example 1.9.1 An electron and a proton are a distance one meter apart. Find the electrical force of attraction between them in mks and cgs systems. Hence find the relation between newton and dyne.

Solution :

$$\begin{aligned} \text{In mks, } F &= \frac{1}{4\pi \epsilon_0} \frac{Q_1 Q_2}{r^2} \\ &= 9 \times 10^9 \times 1.6 \times 10^{-19} \times 1.6 \times 10^{-19} \\ &= 23.04 \times 10^{-29} \text{ N} \end{aligned}$$

$$\begin{aligned} \text{In cgs, } F &= \frac{Q_1 Q_2}{r^2} \\ &= 4.8 \times 10^{-10} \times 4.8 \times 10^{-10} \\ &= 23.04 \times 10^{-24} \text{ dyne} \end{aligned}$$

$$\therefore 23.04 \times 10^{-29} \text{ N} = 23.04 \times 10^{-24} \text{ dyne}$$

$$\text{or } 1 \text{ N} = 10^5 \text{ dyne}$$

1.10 Effect of medium on Coulomb interaction :

It is important to recollect here that the eqn. (1.9.2) represents the force of interaction between two point charges in vacuum. It can easily be shown by an experiment that if a material medium is present between the two point charges, the force F between them will be reduced. The amount of reduction of force

depends on the influence of the medium and it is taken care of by replacing ϵ_0 in eqn. (1.9.2) by ϵ , known as permittivity of the medium.

Electric permittivity (ϵ):

Electric permittivity of a medium gives a measure of that characteristic property of the medium surrounding electric charge which determines the force between the charges. Permittivity is the ability of a dielectric to concentrate electric flux. It is usual to write $\epsilon = \epsilon_0 \epsilon_r$ where ϵ_r is known as relative permittivity and it is defined as follows :

$$\epsilon_r = \frac{\epsilon}{\epsilon_0} = \frac{\text{permittivity of the medium}}{\text{permittivity of free space}}$$

Also $\epsilon_r = K$ where K is known as dielectric constant of the medium.

The force of Coulomb interaction between two point charges Q_1 and Q_2 situated in a medium of permittivity ϵ and dielectric constant K , on using eqn. (1.9.2) can be written as

$$F' = \frac{1}{4\pi \epsilon} \frac{Q_1 Q_2}{r^2} \quad \dots 1.10.1$$

$$= \frac{1}{4\pi \epsilon_0 K} \frac{Q_1 Q_2}{r^2} \quad \dots 1.10.2$$

From eqn. (1.9.2), (1.10.1) and (1.10.2) it can easily be shown that

$$\frac{F}{F'} = \frac{\epsilon}{\epsilon_0} = \epsilon_r = K$$

$$\text{or } F' = \frac{F}{K}$$

The force between two point charges in a medium of dielectric constant K , is reduced by a factor of $\frac{1}{K}$ when compared with the force between the two charges situated in vacuum. Dielectric constant (K) of a dielectric medium

is the characteristic of the medium. It is dimensionless. Its value is same both in cgs and S.I. units. Its minimum value is unity for vacuum and maximum value is infinity for good conductors.

The values of dielectric constants for some dielectric media are given for reference in table (1.2)

Table 1.2 Dielectric constants

Gases :

Air	1.0006
Hydrogen	1.00026
Carbon dioxide	1.00097

Liquids :

Alcohol	25
Oil	2 - 2.2
Turpentine	2.2 - 2.3
Water	80 - 83

Solids :

Glass	6 - 10
Mica	5.6 - 6.6
Paraffin wax	2 - 2.6
Procelain	6 - 7

1.11 Dimensions of permittivity ϵ :

In the branch of electricity, besides the dimensions [M], [L] and [T], we have [A] for electric current or [Q] for electric charge. [Q] and [A] are related to each other by the relation

$$[Q] = [AT]$$

From eqn. (1.10.1), we have

$$\epsilon = \frac{Q_1 Q_2}{4\pi Fr^2}$$

$$[\epsilon] = \frac{[Q^2]}{[MLT^{-2}][L^2]}$$

$$[\epsilon] = [M^{-1}L^{-3}T^2Q^2] \text{ in } [MLTQ]$$

$$= [M^{-1}L^{-3}T^4A^2] \text{ in } [MLTA]$$

1.12 Principle of Superposition of Coulombs forces :

Coulomb's law is used to calculate the force between two point charges. Principle of superposition enables us to find the force on a point charge due to multiple point charges.

Principle of superposition states that when there are a group of point charges in a medium, the force between any two point charges is independent of the presence of all other point charges. The force on any point charge is the vector sum of individual forces due to all other point charges in accordance with coulomb's law.

1.13 Force on a charge due to a multiple electric charges :

Consider a set of point charges $Q_1, Q_2, Q_3, \dots, Q_n$. Their position vectors respectively are $\vec{r}_1, \vec{r}_2, \vec{r}_3, \dots, \vec{r}_n$ as shown in the fig. (1.3)

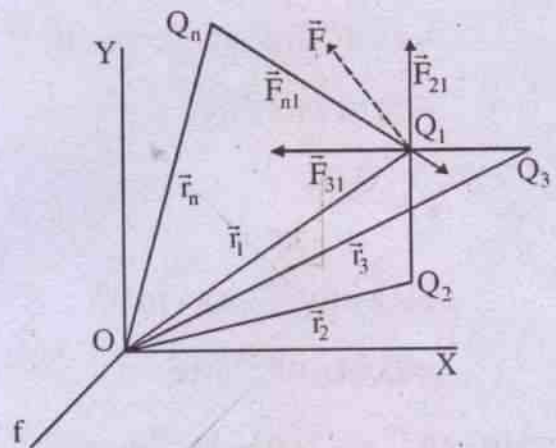

Fig. 1.3

In free space, the force on the charge Q_1 due to charge Q_2 is given by

$$\vec{F}_{21} = \frac{Q_1 Q_2}{4\pi \epsilon_0 r_{21}^2} \hat{r}_{21}$$

Similarly the force $\vec{F}_{31}, \dots, \vec{F}_{n1}$ are given by

$$\vec{F}_{31} = \frac{Q_1 Q_3}{4\pi \epsilon_0 r_{31}^2} \hat{r}_{31}$$

$$\vec{F}_{n1} = \frac{Q_1 Q_n}{4\pi \epsilon_0 r_{n1}^2} \hat{r}_{n1}$$

The total force on Q_1 due to all other charges Q_2, Q_3, \dots, Q_n in free space is

$$\begin{aligned} \vec{F} &= \vec{F}_{21} + \vec{F}_{31} + \dots + \vec{F}_{n1} \\ &= \frac{1}{4\pi \epsilon_0} \left[\frac{Q_1 Q_2}{r_{21}^2} \hat{r}_{21} + \frac{Q_1 Q_3}{r_{31}^2} \hat{r}_{31} + \dots + \frac{Q_1 Q_n}{r_{n1}^2} \hat{r}_{n1} \right] \end{aligned}$$

where $r_{21}, r_{31}, \dots, r_{n1}$ are the distances between Q_2 and Q_1, Q_3 and Q_1, \dots, Q_n and Q_1 respectively and $\hat{r}_{21}, \hat{r}_{31}, \dots, \hat{r}_{n1}$ are their respective unit vectors.

Example 1.13.1 Three identical charges each of charge q are placed on three vertices of an equilateral triangle of each side of length 'a'. Find force on any one of the charges due to other two charges.

Solution :

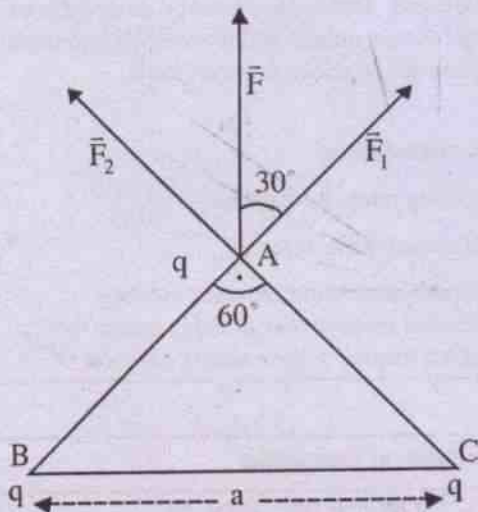

Fig. 1.4

Forces on the charge q at A due to charges at B and C are equal in magnitude :

$$|\vec{F}_1| = |\vec{F}_2| = \frac{q^2}{4\pi \epsilon_0 a^2}$$

Resultant $\vec{F} = \vec{F}_1 + \vec{F}_2$

$$|\vec{F}| = \sqrt{F_1^2 + F_2^2 + 2F_1 F_2 \cos 60^\circ}$$

$$= \frac{q^2}{4\pi \epsilon_0 a^2} \sqrt{1+1+1}$$

$$= \frac{\sqrt{3}q^2}{4\pi \epsilon_0 a^2}$$

Direction of \vec{F} :

\vec{F} bisects the angle between \vec{F}_1 and \vec{F}_2 as their magnitudes are equal. Hence \vec{F} makes 30° with \vec{F}_1 as shown in the fig. 1.4

Example 1.13.2 Two pith balls each weighing 19.6×10^{-5} kg are suspended from the same point A by two silk threads each 1.0 m long. The two pith balls have identical charge and repel each other making an angle 90° at the apex A. Calculate magnitude of each charge.

Solution :

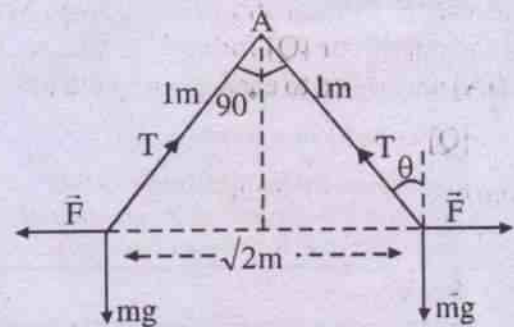

Fig. 1.5

It is clear from the fig (1.5) that, for equilibrium of the pith ball,

$$T \cos \theta = mg$$

$$T \sin \theta = F$$

$$F = mg \tan \theta = mg \quad (\because \theta = 45^\circ)$$

But $F = \frac{q^2}{4\pi \epsilon_0 r^2} = mg$

$$q^2 = 4\pi \epsilon_0 r^2 mg$$

$$= \frac{2 \times 19.6 \times 10^{-5} \times 9.8}{9 \times 10^9} \quad (\because r = \sqrt{2}m)$$

$$\therefore q = \frac{19.6}{3} \times 10^{-7} = 0.65 \mu\text{C}$$

1.14 Salient features of coulomb interaction

- Coulomb's law is an experimental law. (Coulomb first established this law on the basis of experiments).
- Coulomb's law is applicable to point charges or charges which are considered to be concentrated at points.
- Coulomb force between any two charges

a) Similarities :

Coulomb interaction	Gravitational interaction
i) Coulomb force is directly proportional to the product of two charges and inversely proportional to square of the distance between them.	Gravitational force is directly proportional to product of two masses and inversely proportional to square of the distance between them.
ii) It is a central force.	It is also central force.
It is a long range interaction.	It is also long range interaction.
iv) It is a conservative force.	It is also conservative force.
v) Coulomb interaction between any two charges is independent of the presence of other charges in their neighbourhood.	Gravitational interaction between any two masses is also independent of the presence of any other masses in their neighbourhood.

b) Dissimilarities :

Coulomb interaction	Gravitational interaction
i) Coulomb force is both attractive and repulsive.	Gravitational force is only attractive.
ii) Coulomb force between two charges depends on intervening medium.	Gravitational force between two masses is unaffected by intervening medium.
iii) Coulomb interaction is very much stronger and about 10^{42} times, that of gravitational interaction between a pair of electrons.	Gravitational interaction is a very weak interaction.

is unaffected by the presence of other charges in their neighbourhood.

- Coulomb force is a central force (as it acts along the line joining the two charges)
- Coulomb force is a conservative force (since work done in moving a charge from one point to another in an electric field is independent of path followed.)
- Coulomb force is an unsaturated force. (Since a single charge can interact with any number of other charges).
- Coulomb force is a long range force.

Coulomb's law has similar mathematical form as that of Newton's law of gravitation

$$(F = G \frac{m_1 m_2}{r^2})$$

but they are fundamentally different. Hence it is worthy of mentioning here the similarities and dissimilarities between these two types of interactions.

1.15 Continuous charge distribution :

Charge is discrete. We cannot think of a charge less than the basic charge i.e. charge of an electron or a proton. All charges are integral multiples of elementary or basic charge. Hence from a microscopic point of view, continuous charge distribution is not possible. However, macroscopic effects of a heavily charged body can be computed by assuming the charge to be continuously distributed in space. This concept is somewhat similar to treating a fluid as continuous in hydrodynamics even though the fluid is composed of molecules.

It is customary to define a continuous charge distribution in terms of a density function which is of three types :

i) Volume charge density (ρ) :

It is defined as the ratio of sum of all charges (Δq) inside a small volume (ΔV) and the small volume (ΔV).

$$\text{Thus } \rho = \frac{\Delta q}{\Delta V}$$

$$\text{or } \Delta q = \rho \Delta V$$

Mathematically, charge density at a point is defined as

$$\rho = \lim_{\Delta V \rightarrow 0} \frac{\Delta q}{\Delta V} = \frac{dq}{dv} \quad \dots 1.15.1$$

$$\text{Thus } q = \int_v \rho dv \quad \dots 1.15.2$$

where the integration is over the volume v .

ii) Surface density of charge (σ) :

In case of charge being distributed in a very thin layer on the surface of a body, we make use of surface density function. *Surface density of charge is defined as ratio of sum of charges (Δq) in a small surface element (ΔS) and the area of the surface element (ΔS).*

$$\text{Hence } \sigma = \frac{\Delta q}{\Delta S}$$

Surface density of charge at a point is defined

$$\text{as } \sigma = \lim_{\Delta S \rightarrow 0} \left(\frac{\Delta q}{\Delta S} \right) = \frac{dq}{dS} \quad \dots 1.15.3$$

$$\text{Thus } q = \int_s \sigma ds \quad \dots 1.15.4$$

where the integral is over the surface S .

iii) Linear density of charge (λ) :

When a charge is distributed along a linear body whose cross section is negligibly small compared to other dimensions, linear charge density is useful to derive electrostatic properties.

Linear charge density (λ) is defined as the ratio of sum of charges (Δq) in a small linear element ($\Delta \ell$) and the linear element ($\Delta \ell$).

$$\text{Thus } \lambda = \frac{\Delta q}{\Delta \ell}$$

Linear charge density at a point is defined

$$\text{as } \lambda = \lim_{\Delta \ell \rightarrow 0} \left(\frac{\Delta q}{\Delta \ell} \right) = \frac{dq}{d\ell}$$

$$\text{Hence } q = \int_{\ell} \lambda d\ell \quad \dots 1.15.6$$

where the integral is a line integral over the length ℓ .

SUMMARY

1. Electrostatics deals with properties of charges at rest.
2. Amber, ebonite, glass etc. on being rubbed with fur attract light objects. This property, acquired by the materials, is due to electrification by friction.

3. Characteristics of charge
- Two types of charge : Positive and Negative.
 - Like charges repel whereas unlike charges attract.
 - Charge is quantized, one quantum of charge is 1.6×10^{-19} C.
 - Charge is conserved.
 - Charge is a scalar quantity and hence they obey scalar addition.
 - Charge is relativistically invariant i.e. the value of a charge does not vary with relative motion with respect to an observer.

4. Coulomb's law

The force of interaction between two point charges q_1 and q_2 separated by a distance r is

$$F = K_0 \frac{q_1 q_2}{r^2}$$

- a) In free space,
- in cgs (esu) $K_0 = 1$

$$F = \frac{q_1 q_2}{r^2}$$

- in SI, $K_0 = \frac{1}{4\pi \epsilon_0}$

$$= 9 \times 10^9 \text{ Nm}^2 \text{ C}^{-2}$$

$$F = \frac{1}{4\pi \epsilon_0} \frac{q_1 q_2}{r^2}$$

- b) In a dielectric medium of dielectric constant K , the force between two charges varies inversely as the dielectric constant.

- in cgs (esu)

$$F = \frac{q_1 q_2}{Kr^2}$$

- in SI

$$F = \frac{1}{4\pi \epsilon_0} \frac{q_1 q_2}{Kr^2}$$

$$= \frac{1}{4\pi \epsilon} \frac{q_1 q_2}{r^2}$$

where ϵ is the permittivity of the medium present in between the two charges.

The dielectric constant K has same value both in cgs (esu) and SI systems.

5. Unit of Charge

- In c.g.s. (esu) system - stat-coulomb.

Stat-coulomb is the amount of charge which when placed at a distance of 1cm in free space from an identical charge, repels it with a force of one dyne.

- In S.I. system - Coulomb

Coulomb is the amount of charge which when placed at a distance of one meter, in free space, from an identical charge, repels it with a force of 9×10^9 Newton.

$$1 \text{ coulomb} = 3 \times 10^9 \text{ stat coulomb}$$

6. Principle of superposition of Coulomb forces

It states that the net force on any point charge, when more than two charges are present, is the vector sum of the individual Coulomb forces on the point charge due to the other charges.

- Coulomb force is a conservative, central, long range, unsaturated, depends on intervening medium and much stronger than gravitational force.

8. Continuous charge distribution is of three types :

- Linear charge distribution and the charge along the length l is

expressed in terms of linear charge density function (λ) as

$$q = \int \lambda dl$$

- ii) Surface charge distribution and the charge on the surface S is expressed in surface charge density (σ) as

$$q = \int \sigma ds$$

- iii) Volume charge distribution and the charge in the volume V is expressed in volume charge density (ρ) as

$$q = \int \rho dv$$

Solved numerical examples :

1. Two identical conducting spheres P and S with charge Q on each repel each other with a force F . A third identical uncharged conducting sphere R is successively brought in contact with the two spheres. What is the new force of repulsion between P and S?

Solution :

When R is brought in contact with P, charge Q is equally distributed between P and R.

$$\therefore \text{Charge on P} = Q/2$$

$$\text{and Charge on R} = Q/2$$

Now R is kept in contact with the sphere S.

Total charge $Q + \frac{Q}{2}$ is equally distributed between the conductors.

\therefore Charge on the conductor

$$S = \frac{Q + \frac{Q}{2}}{2} = \frac{3Q}{4}$$

Initial force of repulsion between P and S is

$$F = \frac{Q^2}{4\pi \epsilon_0 r^2}$$

Final force of repulsion between P and S is

$$\begin{aligned} F' &= \frac{1}{4\pi \epsilon_0} \frac{Q/2 \times 3Q/4}{r^2} \\ &= \frac{3}{8} \frac{1}{4\pi \epsilon_0} \frac{Q^2}{r^2} \\ &= \frac{3}{8} F. \end{aligned}$$

2. Compare the electrostatic and gravitational forces between the electron and the proton of a hydrogen atom.

(Given: $m_e = 9.1 \times 10^{-31}$ kg, $m_p = 1.67 \times 10^{-27}$ kg
 $e = 1.6 \times 10^{-19}$ Coulomb, $G = 6.67 \times 10^{-11}$ Nm²kg⁻²)

Solution :

Electrostatic force of attraction,

$$F_e = \frac{1}{4\pi \epsilon_0} \frac{Q_1 Q_2}{r^2}$$

Gravitational force of attraction,

$$F_g = G \frac{m_e m_p}{r^2}$$

$$\frac{F_e}{F_g} = \frac{1}{4\pi \epsilon_0} \frac{1}{G} \frac{Q_1 Q_2}{m_e m_p}$$

$$= \frac{9 \times 10^9}{6.67 \times 10^{-11}} \times \frac{1.6 \times 10^{-19} \times 1.6 \times 10^{-19}}{9.1 \times 10^{-31} \times 1.67 \times 10^{-27}}$$

$$= 2.3 \times 10^{39}$$

3. The distance between electron and proton in a hydrogen atom is 0.53 \AA . Find the electric force of attraction.

Solution :

Given $Q_1 = Q_2 = 1.6 \times 10^{-19}$ Coul,

$$r = 0.53 \times 10^{-10} \text{ m}$$

$$F = \frac{1}{4\pi \epsilon_0} \cdot \frac{Q_1 Q_2}{r^2}$$

$$= \frac{9 \times 10^9 \times 1.6 \times 10^{-19} \times 1.6 \times 10^{-19}}{(0.53 \times 10^{-10})^2}$$

$$= 8.2 \times 10^{-8} \text{ N}$$

4. Two point charges $4Q$ and Q are situated a distance d apart. Find the position of the third charge q , so that it will be in equilibrium. Discuss whether the charge q is in stable or unstable equilibrium.

Solution :

Consider the charge q at a distance x from $4Q$ on the line joining $4Q$ and Q . As the charge q is in equilibrium, net force on q is zero.

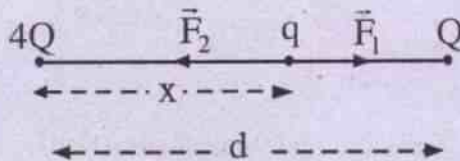

Fig. 1.6

$$\therefore |\vec{F}_1| = |\vec{F}_2|$$

$$\frac{4Qq}{4\pi \epsilon_0 x^2} = \frac{Qq}{4\pi \epsilon_0 (d-x)^2}$$

$$4(d-x)^2 = x^2$$

$$2(d-x) = \pm x$$

Solving $x = \frac{2d}{3}$ or $2d$

x cannot be equal to $2d$ in which case the forces exerted on q due to $4Q$ and Q will be in the same direction and it cannot be in equilibrium.

$$\therefore x = 2d/3$$

For equilibrium, q can be negative or positive.

- If the charge q is positive, it is in stable equilibrium, along the line joining the charges $4Q$ and Q but in unstable equilibrium in a direction perpendicular to the line joining $4Q$ and Q because a small displacement of charge q , will make the charge q to go away from them.
- If the charge q is negative, it is in unstable equilibrium along the line joining the charges $4Q$ and Q but in stable equilibrium in a direction perpendicular to the line joining $4Q$ and Q .

(A body is said to be in equilibrium, when the net force acting on it is zero. Imagine the body to be displaced by a small distance from its equilibrium position. If it comes back to the equilibrium position, the body is said to be in stable equilibrium. Otherwise the body is said to be in unstable equilibrium)

5. The force of attraction between two charges in free space is found to be same when they are kept in a dielectric medium and the separation between them is reduced to half the distance they were in free space. Find the dielectric constant of the medium.

Solution :

$$\text{In free space } F = \frac{1}{4\pi \epsilon_0} \cdot \frac{Q_1 Q_2}{r^2}$$

In a dielectric medium,

$$F_d = \frac{1}{4\pi \epsilon_0 K} \cdot \frac{Q_1 Q_2}{\left(\frac{r}{2}\right)^2}$$

$$\frac{F}{F_d} = 1 = \frac{K}{4}$$

$$\therefore K = 4.$$

6. Find the relation between coulomb and stat coulomb.

Suppose 1 coul = x stat coul.

Consider two point charges each of q coul separated by a distance of r meters in free space.

In S.I. the coulomb force between them

is
$$F = \frac{1}{4\pi\epsilon_0} \cdot \frac{q^2}{r^2} = 9 \times 10^9 \frac{q^2}{r^2} \text{ N}$$

In e.s.u.,

$$F = \frac{(xq)(xq)}{(100r)^2} \text{ dyne} = \frac{x^2 q^2}{10^4 r^2} \times 10^{-5} \text{ N}$$

$$\therefore 9 \times 10^9 \frac{q^2}{r^2} = \frac{x^2 q^2}{r^2} \times 10^{-9}$$

$$\text{or } x^2 = 9 \times 10^{18}$$

$$\text{or } x = 3 \times 10^9$$

Thus 1 coul = 3×10^9 stat-coul.

MODEL QUESTIONS

A. Multiple Choice Type Questions :

1. Which of the following is the unit of electric charge
 - a) Coulomb
 - b) Stat-coulomb
 - c) Abcoulomb
 - d) All the above
2. The electrostatic force between two charges Q_1 and Q_2 separated by a distance r is given by $F = K \frac{Q_1 Q_2}{r^2}$. The constant K
 - a) depends on the system of units only
 - b) depends on the medium between the charges only.
 - c) depends on both (a) and (b)
 - d) None of the above.
3. The force between Q_1 and Q_2 is F . If a third charge Q_3 is brought near Q_1 , the force between Q_1 and Q_2 is F' (Say). Then
 - a) $F' = F$
 - b) $F' > F$
 - c) $F' < F$
 - d) F' may be greater or less than F
4. The coulomb force of attraction between two charges separated by a distance is $4N$. If a dielectric medium of dielectric constant 2 is kept to fill the space between them, the force of attraction now becomes
 - a) $8N$
 - b) $4N$
 - c) $6N$
 - d) $2N$
5. A body is positively charged. It has
 - a) excess of positrons
 - b) excess of electrons
 - c) deficit of electrons
 - d) deficit of protons.
6. If F_e and F_g are the electric and gravitational forces respectively between an electron and proton situated at a distance apart, the ratio of F_e and F_g is of the order of
 - a) 10^{-39}
 - b) 10^{39}
 - c) 1
 - d) 10^{43}
7. An isolated conducting sphere is given a positive charge by rubbing. Its mass
 - a) increases
 - b) decreases
 - c) remains the same
8. The dimensions of ϵ_0 are
 - a) $[M^3 L^{-2} T^2 A^3]$
 - b) $[M^0 L^0 T^0 A^0]$
 - c) $[M^{-1} L^{-3} T^4 A^2]$
 - d) $[M^{-1} L^{-3} T^3 A^2]$
9. A body has a positive charge of $1\mu C$. It has
 - a) 6.25×10^{12} electrons in excess
 - b) 6.25×10^{12} electrons in deficit
 - c) 10^6 electrons in excess
 - d) 10^6 electrons in deficit.
10. A proton at rest has a charge e . When it moves with a high speed, its charge
 - a) $> e$
 - b) $< e$
 - c) $= e$
 - d) may increase or decrease.

B. Very Short Answer Type Questions :

1. What is electrostatics ?
2. Name the Scientist who first showed that two kinds of charges exist.
3. Name the Scientist who first assigned algebraic signs to the two charges.
4. What is the nature of charge present on an abonite rod when it is rubbed with fur?
5. State Coulomb's law of electric force between two charged bodies.
[CHSE 1989 (s)]
6. Does Coulomb's law of electric force obey Newtons third law of motion?
7. What is the value and dimensional formula for ϵ_0 ?
8. Define one Coulomb.
9. What is a point charge ?
10. A body can have a charge of 1.0×10^{-19} coulomb. True or false.
11. The force between two charges in free space is F . If a dielectric medium of dielectric constant K is placed, the force between two charges is _____.
12. Is coulomb force a central force ?
13. What is the minimum amount of charge that can be given to a body ?
14. Two charges $+1\mu\text{C}$ and $+5\mu\text{C}$ are placed 0.1 cm apart. What is the ratio of the coulomb force acting on each of the two charges. [CHSE 2002 A]
15. Which of the following forces is the strongest - gravitational, nuclear, electrostatic? [CHSE 2002 A]
16. Name to basic properties of electric charge. [CBSE AI 2005]
17. The force acting between two point charges q_1 & q_2 , kept at some distance apart in air is attractive or repulsive

(i) $q_1, q_2 > 0$ (ii) $q_1, q_2 < 0$ [CBSE(F) 2007]

18. What dose $q_1 + q_2 = 0$, signify in electrostatics ? [CBSE 2001]

C. Short Answer Type Questions :

1. What is quantisation of charge ?
2. How many electrons constitute a Coloumb?
3. What are the important properties of electric charge ?
4. Give two points of distinction between charge and mass.
5. What is the dimensional formula for K_0 in Coulomb's law.
6. Is Coulomb a very big unit of charge? Justify.
7. Is the Coulomb force between two electrons greater than gravitational force between them ? If so by what factor ?
8. Charge is additive. What do you mean by this ?
9. What do you understand by the principle of superposition of Coulomb forces ?
10. Why does a phonograph record attract dust particles just after it is cleaned ?
11. State whether the force between two charges will be changed when a third charge is brought near them ?
12. When a charged comb is brought near a small piece of paper, it attracts. Does the paper become charged before being attracted ?
13. A glass rod is rubbed with fur. After rubbing, the glass becomes slightly heavy. True or false.
14. A Polythene piece rubbed with wool is found to have a negative charge of $1\mu\text{C}$. Estimate the number of electrons

- transferred. Is there any transfer of a mass from wool to polythene?
15. A comb run through one's dry hair attracts small bits of paper, why? What happens if the hair is wet?
 16. Vehicles carrying inflammable material usually have metallic ropes touching the ground during motion, why?
 17. How can one ignore quantization of electric charge when dealing with macroscopic or large scale charge?

[CBSE Sample Paper]

D. Numerical Problems :

1. The distance between electron and proton in a hydrogen atom is 0.53 \AA . Find the speed and frequency of revolution of electron round the proton. ($m_e = 9.1 \times 10^{-31} \text{ kg}$)
2. A spherical conductor having a charge of $100 \mu\text{C}$ is brought near another metallic sphere (of mass 36 kg) resting on earth's surface. What minimum distance of separation should be maintained so as to lift up the metallic sphere with uniform speed. What happens if the separation is more or less than the calculated value. (assume $g = 10 \text{ mS}^{-2}$).
3. Two identical charges are placed at a separation of 1.0 m . What should be the magnitude of each charge, so that each one repels the other with a force of 36 kg wt . ($g = 10 \text{ mS}^{-2}$)
4. Find the coulomb force between two protons in a nucleus if the average distance between two protons in a nucleus is 6 fermi .
5. Two charged particles are a distance 1 mm apart. Find the minimum coulomb force between them.
6. Glass ball is rubbed with ebonite ball and kept at a separation of 1 cm . If the force of attraction between them is 10 N find charge on each ball.
7. Find the ratio of electric and gravitational forces between two protons when they are kept at a distance apart.
8. Three equal charges each of $1 \mu\text{C}$ are placed at the three corners of an equilateral triangle of sides 3 cm each. Find the force experienced by each charge due to the other two charges.
9. Four equal charges $1 \mu\text{C}$ each are placed at the four corners of a square of each side 3 cm . Find the force experienced by each charge due to the other three charges.
10. An infinite number of identically charged bodies are kept along the x axis at points $x = 0, 1 \text{ m}, 2 \text{ m}, 4 \text{ m}, 8 \text{ m}, 16 \text{ m}$ and so on. All other charges repel the charge at the origin with a force of 1.2 N . Find magnitude of each charge.
11. Four point charges each of charge $-4 \mu\text{C}$ are placed at the four corners of a square such that they are in equilibrium when a charge q is placed at its centre. Find q .
12. Two insulated charged metallic spheres A and B have their centres separated by a distance of 50 cm in air (a) calculate the force of repulsion between them if the charge on each is $+5.0 \times 10^{-8} \text{ C}$. (b) calculate the force of repulsion between them when the two spheres are placed in water. (dielectric constant of water is 81.0)
13. Two similar spheres each of mass m and carrying equal charges q are hung from a common point by means of two silk threads each of length ℓ . Show that the

separation x between them is given by

$$x = \left(\frac{q^2 \ell}{2\pi \epsilon_0 mg} \right)^{1/3}$$

when the angle θ between the threads is very small.

14. Four equal positive charges each of value Q are arranged at the four corners of a square of side 'a' each. A body of mass m and having a unit positive charge is in equilibrium at a height h above the centre of the square. Find Q .
15. Three charges of magnitude $100\mu\text{C}$ each are placed at the three corners A, B and C of an equilateral triangle measuring 4 meters on each side. If the charges at A and C are positive and the charge at B is negative, what is the direction and magnitude of total force on the charge at C.
16. A charge q is placed at the centre of the line joining two equal charges Q . show that the system of three charges will be in equilibrium if $q = -Q/4$. [CBSE AI 2005]
17. Three point charges $+2\mu\text{C}$, $-3\mu\text{C}$ and $-3\mu\text{C}$ are kept at the vertices A, B, C respectively of an equilateral triangle of side 20 cm. What should be the sign and magnitude of charge to be placed at the midpoint M of side BC so that the charge at A remains in equilibrium? [CBSE 2005]
18. Two identical metallic spheres, having unequal opposite charges are placed at a distance of 0.50 m apart in air. After bringing them in contact with each other, they are placed at the same distance apart. Now the force of repulsion between them is 0.108 N. Calculate the final charge on each of them. [CBSE 2002]

E. Long Answer Type Questions :

1. Discuss different characteristics of charge. What do you mean by conservation of charge?
2. What do you mean by electrification? Discuss various ways of electrifying a body. How can you charge a conductor positively by induction?
3. State Coulomb's law in electrostatics and hence define unit of charge in e.s.u and S.I. system.
4. State the principle of superposition in electrostatics. Obtain an expression for force on one charge due to all other charges present in its neighbourhood.

F. True - False Type Questions :

1. Two identical metallic spheres of exactly equal masses are taken. One is given a positive charge Q coulomb and the other an equal negative charge, Their masses after charging are different.
2. Coulomb's law holds good for all distances greater than distances of the order 10^{-15}m .
3. Force between two charges increases if a wooden slab is kept between them.
4. A charge q_1 exerts some force \vec{F}_1 on a second charge q_2 . If a third charge q_3 is brought near, the force of q_1 on q_2 changes.
5. A solid conducting sphere hold more charge than a hollow sphere of same radius.
6. When the distance between two charged particles is halved, the force between them becomes four times.
7. Force between two charges separated by a distance r varies as r^2 .
8. Force between two charges is governed by Ampere's law.

9. Coulomb is the unit of charge in S.I. system.
10. The ratio of gravitational force and electrostatic force between two electrons separated by a distance of 10 cm is of the order of 10^{42} .
- G. Fill in Blank Type Questions**
1. A soap bubble is given a negative charge. Its radius.....
 2. The positive charge which must be given to the earth and moon so that gravitational attractive force between them is nullified by electric repulsive force is.....
 3. The ratio of the forces between two small spheres with constant charges (a) in air (b) in a medium of dielectric constant K is respectively.
 4. In S.I. system of units $\frac{1}{4\pi\epsilon_0}$ is equal to...
 5. The force between two electrons separated by a distance r varies as
 6. The law governs the force between two static charges.
 7. An isolated conducting sphere is given a positive charge by rubbing. Its mass.....
8. A proton at rest has a charge e. When it moves with high speed $\cdot g \cdot$ its charge is
9. A body has a positive charge of $1\mu\text{c}$. It has electrons in deficit.
10. Dimension of ϵ_0 is
- H. Correct the following sentences :**
1. Chрге on a body can be any multiple of electron charge.
 2. A body is negatively charged if it loses electrons.
 3. In S.I system of units $1/4\pi\epsilon_0$ is equal to $6 \times 10^9 \text{Nm}^2/\text{C}^2$
 4. The charge on an electron is 1.6×10^{-9} coulomb.
 5. Gauss's law governs the force between two charges.
 6. Force between two charges increases if a wooden slab is kept between them.
 7. Force between two charges varies directly as the sqare of the distance between them.

2

Electric Field and Potential

2.1 Electric Field :

It is difficult to visualise the force between two charged bodies as there is no physical contact between them. To explain this, in the nineteenth century, Faraday introduced the concept of field which was subsequently developed by Maxwell. Accordingly electric force between two charged bodies is a two step process :

a) A charged body known as source charge creates an electric field around it.

b) This field acting on any other charge present in it produces a force but it cannot exert a force on the source itself.

The electric field thus plays an intermediary role to produce the force between two charges and its introduction is inevitable for understanding interactions between the charged bodies. Moreover, the region in which the electric field is present gets modified.

Now we are in a position to define an electric field. *Electric field is a region of space surrounding a charge, or a system of charges in which any other charge brought in, experiences a force. It is to be noted that electric field exists around a system of charges even if there is no charge to realise its effect.*

An electric field has two important characteristics : direction and magnitude. The direction of the electric field at a point is the direction of the force experienced by a positive charge placed at that point. Hence electric field at a point near a positive charge is directed away from it whereas it is directed towards a negative charge.

2.2 Electric field intensity or electric field strength :

The quantitative measure of the strength of an electric field is known as electric field intensity. *Electric field intensity at a point due to a charge or a configuration of charges is defined as the force experienced by a unit positive test charge placed at that point.*

$$\vec{E} = \frac{\vec{F}}{q_0} \quad \dots(2.2.1)$$

where \vec{E} is the electric field intensity. \vec{F} is the force experienced by positive test charge q_0 . (Test charge is a positive charge of such a small magnitude that, its presence at a point does not disturb the electric field to be measured at that point)

Electric field intensity is a vector quantity. Consequently electric fields, must be added vectorially. Its unit in SI is Newton per Coulomb and in esu is dyne per stat Coulomb.

Example 2.2.1 What is the force experienced by an α particle in a uniform electric field of intensity $5 \times 10^{-4} \text{ N/C}$.

Solution :

The force experienced by an α -particle is

$$\begin{aligned} F &= Eq \\ &= 5 \times 10^{-4} \times 2 \times 1.6 \times 10^{-19} \\ &= 1.6 \times 10^{-14} \text{ N} \end{aligned}$$

2.3 Electric field intensity due to point charge :

Consider a point charge Q . Let q_0 be the test charge placed at a distance r from it as shown in the fig. 2.1.

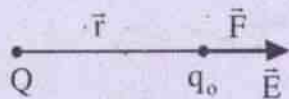

Fig. 2.1

In accordance with Coulomb's law the force experienced by test charge q_0 in free space is,

$$\vec{F} = \frac{Qq_0}{4\pi \epsilon_0 r^2} \hat{r} \quad \dots(2.3.1)$$

where \hat{r} is the unit vector in the direction from Q to q_0 . By definition, the electric field intensity \vec{E} due to a point charge Q at the position of test charge is given by

$$\vec{E} = \frac{\vec{F}}{q_0} = \frac{1}{4\pi \epsilon_0} \cdot \frac{Q}{r^2} \hat{r} \quad \dots(2.3.2)$$

The direction of \vec{E} is along the line joining the charge Q and q_0 pointing outward if Q is positive (fig. 2.1) and inward if Q is negative.

Example 2.3.1 Find the electric field intensity at the location of electron in hydrogen atom if the distance between proton and electron is 0.5 \AA .

Solution :

The electric field intensity at the location of the electron due to the proton is given by

$$E = \frac{1}{4\pi \epsilon_0} \cdot \frac{Q}{r^2}$$

Here $Q = 1.6 \times 10^{-19} \text{ coul}$, $r = 0.5 \times 10^{-10} \text{ m}$

$$\begin{aligned} \therefore E &= \frac{9 \times 10^9 \times 1.6 \times 10^{-19}}{(0.5 \times 10^{-10})^2} \\ &= 5.76 \times 10^{11} \text{ N/C} \end{aligned}$$

2.4 The Electric field intensity due to a group of discrete charges :

To find the electric field intensity due to a group of n point charges, Q_1, Q_2, \dots, Q_n , we calculate electric field intensities due to individual charges $\vec{E}_1, \vec{E}_2, \dots, \vec{E}_n$ at the given point and add them vectorially, i.e. :

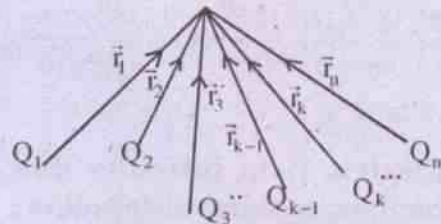

Fig.2.1(a)

$$\vec{E} = \vec{E}_1 + \vec{E}_2 + \dots + \vec{E}_n \quad \dots(2.4.1)$$

$$= \frac{1}{4\pi \epsilon_0} \left[\frac{Q_1}{r_1^2} \hat{r}_1 + \frac{Q_2}{r_2^2} \hat{r}_2 + \dots + \frac{Q_n}{r_n^2} \hat{r}_n \right]$$

$$= \frac{1}{4\pi \epsilon_0} \sum_{k=1}^n \frac{Q_k}{r_k^2} \hat{r}_k \quad \dots(2.4.2)$$

where r_k is the distance from the charge Q_k to the point where electric field intensity is to be calculated. \hat{r}_k is the unit vector and its direction is from K^{th} charge to the point.

Example 2.4.1 An electron and a proton are placed at a distance of 1.0 \AA in free space from each other. Calculate electric field intensity at the point midway between them.

Solution :

Electric field strength due to the proton (E_p) and due to electron (E_e) are in the same direction as shown in the fig. (2.2).

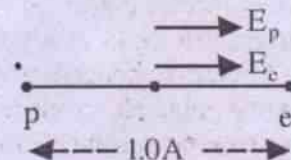

Fig. 2.2

$$\begin{aligned} \therefore E &= E_p + E_e \\ &= \frac{Q_1}{4\pi \epsilon_0 r_1^2} + \frac{Q_2}{4\pi \epsilon_0 r_2^2} \end{aligned}$$

Here $|Q_1| = |Q_2| = 1.6 \times 10^{-19}$ coul,

$$r_1 = r_2 = 0.5 \times 10^{-10} \text{ m}$$

$$\therefore E = \frac{9 \times 10^9 \times 1.6 \times 10^{-19}}{0.5 \times 10^{-10}} + \frac{9 \times 10^9 \times 1.6 \times 10^{-19}}{0.5 \times 10^{-10}}$$

$$E = 57.6 \text{ N/C}$$

2.5 Electric field intensity due to a continuous charge distribution :

Let dq be an infinitesimally small element of a continuous charge distribution. Electric

field intensity \vec{dE} at a point due to the element of charge dq is

$$\vec{dE} = \frac{1}{4\pi \epsilon_0} \cdot \frac{dq}{r^2} \hat{r} \quad \dots(2.5.1)$$

where r is the distance from the element of charge dq to the point where electric field strength is to be calculated. \hat{r} is the unit vector. The resultant field strength due to whole of the charge distribution is obtained by integration of the above eqn. (2.5.1).

$$\vec{E}(\vec{r}) = \int d\vec{E} = \frac{1}{4\pi \epsilon_0} \int \frac{dq}{r^2} \hat{r} \quad \dots(2.5.2)$$

The integral of eqn. (2.5.2) may be a line, surface or volume integral depending on whether the charge distribution is a linear, surface or volume distribution respectively.

i) For a linear charge distribution :

$$dq = \lambda d\ell$$

$$\vec{E}(\vec{r}) = \frac{1}{4\pi \epsilon_0} \int \frac{\lambda dq}{r^2} \hat{r}$$

where λ is the charge per unit length and $d\ell$ is the length of small element of linear charge. The integration is over entire length ℓ of the line charge.

ii) For a surface charge distribution :

$$dq = \sigma ds$$

$$\vec{E}(\vec{r}) = \frac{1}{4\pi \epsilon_0} \int \frac{\sigma dq}{r^2} \hat{r}$$

where σ is the surface charge density and ds is the small element of surface area s . Integration is over entire surface area s over which charge is distributed uniformly.

iii) For a volume charge distribution :

$$dq = \rho d\mathcal{V}$$

$$\vec{E}(\vec{r}) = \frac{1}{4\pi \epsilon_0} \int \frac{\rho d\mathcal{V}}{r^2} \hat{r}$$

where ρ is the volume charge density and $d\mathcal{V}$ is the small volume element of the volume \mathcal{V} . Integration is over entire volume \mathcal{V} in which charge is distributed continuously.

2.6 Lines of force :

A line of force in an electric field is a curve (line) so drawn that a tangent to it at any point gives the direction of the electric field at that point.

Faraday introduced the concept of lines of force. Accordingly, an electric field can be represented graphically by a number of lines of force. These lines help us to compare qualitatively the strengths of the electric field at different points and determine the direction of electric field at various points. Thus they give a picture of how \vec{E} varies in a given region of space. Fig (2.3) shows electric lines of force

near (a) a positive charge (b) a negative charge (c) two equal positive charges and (d) two equal and opposite charges.

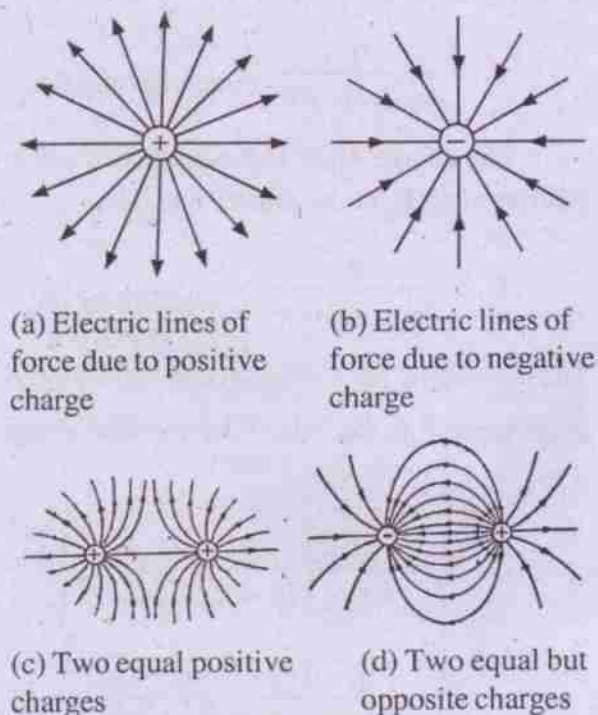

Fig. 2.3

Quantitative aspect can be associated with lines of force by defining electric field strength at a point in terms of electric lines of force as follows :

The magnitude of electric field intensity at a point is proportional to the number of lines of force per unit area, area being normal to the electric field, in the neighbourhood of the point. This clearly implies that in the region of closely packed lines, the field is stronger than the field in the region where the lines of force are wide apart.

2.7 Properties of electric lines of force :

- i) Lines of force are a purely imaginary geometrical construction aiding the visualisation of the pattern of variation of electric field in space.
- ii) Lines of force originate at a positive charge and are directed radially

away (fig. 2.3a). Lines of force are directed towards a negative charge (fig. 2.3b).

- iii) Lines of force originate at positive charge and terminate at negative charge if it is present in the neighbourhood of positive charge (Fig. 2.3d).
- iv) Lines of force never cross each other, otherwise there will be two directions of electric field at the point of intersection which is not possible because the electric field is a single valued vector point function.
- v) Closer are the lines of force, stronger is the electric field and farther apart are the lines of force, weaker is the electric field. For uniform electric field, lines of force are parallel and equidistant.
- vi) Lines of force from a charged conductor originate or terminate (depending on whether the conductor is positively or negatively charged respectively) normally to its surface.
- vii) Electric lines of force never pass through a conductor. Hence electric field intensify inside a charged conductor is zero.

2.8 Electric dipole :

Two equal and opposite charges separated by a small distance constitute an electric dipole. As its name implies, an electric dipole has two poles: its positive charge is known as positive pole while its negative charge is called negative pole. A line passing through these two poles is known as *dipole axis*. Perpendicular line to the dipole axis and passing through the mid point of the dipole is called *dipole equator*.

An important parameter of a dipole which determines the strength of its influence on a charge placed in its field is *dipole moment*.

Dipole moment (\vec{p}) of an electric dipole is defined as the product of magnitude of one of its charges (q) and distance between them (2ℓ).

$$\vec{p} = 2q\vec{\ell} \quad \dots(2.8.1)$$

(For convenience distance between the two poles of the dipole is taken as 2ℓ)

Dipole moment is a vector quantity. Its direction is from $-q$ to $+q$. $2\vec{\ell}$, thus represents the vector distance from $-q$ to $+q$ of the dipole.

Unit of dipole moment :

- i) In S.I.-Cm (Coulomb-meter)
- ii) In cgs (esu)-statcoul cm.

An ideal dipole :

An ideal dipole is one in which charge of each pole tends to infinity while separation between two poles tends to zero such that their product $P = 2q\ell$ is finite. An ideal dipole is just a point dipole having no size.

2.9 Electric field due to an electric dipole :

i) At a point on the dipole axis (End-on-position)

Consider an electric dipole AB, consisting of two poles, $-q$ at A and $+q$ at B, separated by a distance 2ℓ .

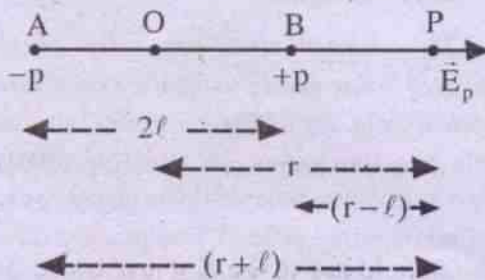

Fig 2.4

Let P be a point on the dipole axis at a distance 'r' from its mid point 'O'.

The charge $-q$ at A produces an electric field strength E_1 at the point P and it is,

$$E_1 = \frac{q}{4\pi\epsilon_0(r+\ell)^2} \text{ directed along PA.}$$

The charge $+q$ at B produces an electric field strength E_2 at the point P and it is,

$$E_2 = \frac{q}{4\pi\epsilon_0(r-\ell)^2} \text{ directed along AP.}$$

The net electric field strength due to the dipole at the point P is $E_p = E_2 - E_1$ directed along AP.

$$\therefore E_p = \frac{1}{4\pi\epsilon_0} \left[\frac{q}{(r-\ell)^2} - \frac{q}{(r+\ell)^2} \right]$$

$$= \frac{q}{4\pi\epsilon_0} \cdot \frac{(r+\ell)^2 - (r-\ell)^2}{(r-\ell)^2(r+\ell)^2}$$

$$= \frac{q}{4\pi\epsilon_0} \cdot \frac{4r\ell}{(r^2 - \ell)^2}$$

$$\vec{E}_p = \frac{1}{4\pi\epsilon_0} \cdot \frac{2Pr}{(r^2 - \ell)^2} \text{ directed along}$$

AP i.e. along the dipole moment

$$= \frac{1}{4\pi\epsilon_0} \cdot \frac{2r\vec{p}}{(r^2 - \ell)^2} \quad \dots(2.9.1)$$

In atomic, molecular and solid state physics we have to deal with fields due to atomic or molecular dipoles at distances very large compared to the dimensions of these dipoles. These are known as far-fields of a dipole. For such fields the point P lies at a distance quite large compared to the length of the dipole i.e.

$r \gg 2\ell$. Then ℓ^2 in eqn. (2.9.1) can be neglected in comparison with r^2 . For far field at end on position of a dipole

$$\vec{E}_p = \frac{1}{4\pi\epsilon_0} \frac{2\vec{p}}{r^3} \quad \dots(2.9.2)$$

ii) *At a point on the dipole equator (Broad-side-on position)*

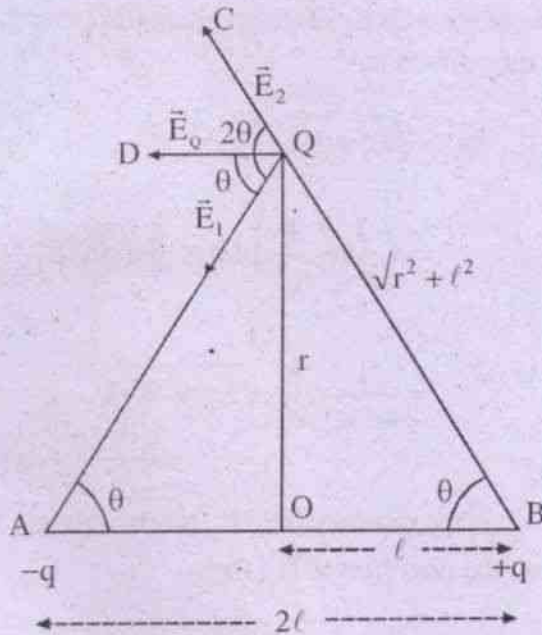

Fig. 2.5

Consider AB an electric dipole, consisting of two poles, -q at A and +q at B, separated by a distance 2l as shown in the fig. (2.5). Let Q be a point on the dipole equator at a distance r from its mid point 'O'.

The charge -q at A produces an electric field strength E_1 at the point Q and it is,

$$\vec{E}_1 = \frac{q}{4\pi\epsilon_0 (r^2 + l^2)} \text{ directed along QA.}$$

QA.

The charge +q at B produces an electric field strength E_2 at the point Q and it is,

$$\vec{E}_2 = \frac{q}{4\pi\epsilon_0 (r^2 + l^2)} \text{ directed along QC.}$$

$$\therefore |\vec{E}_1| = |\vec{E}_2| = \frac{q}{4\pi\epsilon_0 (r^2 + l^2)}$$

The ΔABQ is an isosceles triangle in which $\hat{A}BQ = \hat{B}AQ = \theta$. Hence the external angle $\hat{A}QC = 2\theta$. Since $|\vec{E}_1| = |\vec{E}_2|$, their resultant \vec{E}_Q bisects the angle between them. Therefore, $\hat{A}QD = \theta$ and \vec{E}_Q is antiparallel to dipole moment \vec{p} .

The magnitude of electric field, due to the dipole, at the point Q is (using parallelogram law of vector addition)

$$\begin{aligned} E_Q &= \sqrt{E_1^2 + E_2^2 + 2E_1E_2 \cos 2\theta} \\ &= E_1 \sqrt{2(1 + 2 \cos 2\theta)} \quad (\because E_1 = E_2) \\ &= \frac{1}{4\pi\epsilon_0} \cdot \frac{q}{(r^2 + l^2)} \sqrt{2 \times 2 \cos^2 \theta} \end{aligned}$$

$$= \frac{1}{4\pi\epsilon_0} \cdot \frac{q}{r^2 + l^2} \cdot 2 \cos \theta$$

$$= \frac{1}{4\pi\epsilon_0} \cdot \frac{q}{r^2 + l^2} \cdot \frac{2l}{\sqrt{r^2 + l^2}}$$

$$\therefore E_Q = \frac{1}{4\pi\epsilon_0} \cdot \frac{P}{(r^2 + l^2)^{3/2}} \quad \dots(2.9.3)$$

$$\therefore \vec{E}_Q = \frac{1}{4\pi\epsilon_0} \cdot \frac{(-\vec{P})}{(r^2 + l^2)^{3/2}}$$

$$\text{(-ve sign because } \vec{E}_Q \text{ is antiparallel to } \vec{P} \text{)} \quad \dots(2.9.4)$$

For far-field due to the dipole at broad side-on position, $l \ll r$, l^2 can be neglected in comparison with r^2 in eqn. (2.10.4)

$$\therefore \vec{E}_Q = \frac{1}{4\pi\epsilon_0} \cdot \frac{(-\vec{P})}{r^3} \quad \dots(2.9.5)$$

iii) *At a general point for far-field :*

To calculate far-field due an electric dipole at a general point, we can make use of eqn. (2.9.2) and eqn. (2.9.5) as follows :

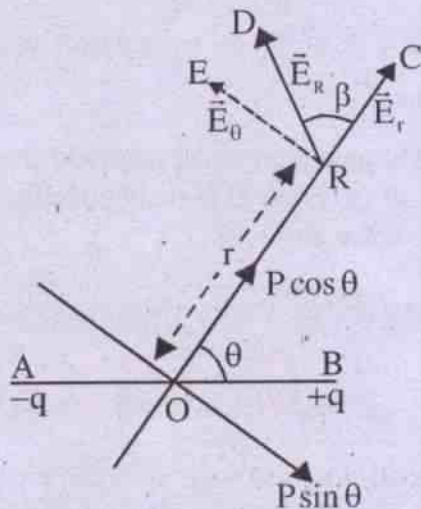

Fig. 2.6

Let R be a general point at a distance r from the mid point 'o' of the dipole AB. Let r make an angle θ with dipole moment \vec{P} as shown in the fig. 2.6. Let us resolve \vec{P} into two rectangular components; one along r (say \vec{P}_1) and another perpendicular to r (Say \vec{P}_2). The two field components E_r and E_θ are then given by eqns (2.9.2) and (2.9.5) respectively as

$$E_r = \frac{1}{4\pi\epsilon_0} \cdot \frac{2P_1}{r^3}$$

$$\text{and } E_\theta = \frac{1}{4\pi\epsilon_0} \cdot \frac{P_2}{r^3}$$

But $P_1 = P \cos \theta$ and $P_2 = P \sin \theta$

$$\text{Hence } E_r = \frac{1}{4\pi\epsilon_0} \cdot \frac{2P \cos \theta}{r^3} \text{ and}$$

$$E_\theta = \frac{1}{4\pi\epsilon_0} \cdot \frac{P \sin \theta}{r^3}$$

The magnitude E_R of the resultant field strength at the point R is,

$$\begin{aligned} E_R &= \sqrt{E_r^2 + E_\theta^2} \\ &= \frac{1}{4\pi\epsilon_0} \cdot \frac{P}{r^3} \cdot [4 \cos^2 \theta + \sin^2 \theta]^{1/2} \\ &= \frac{1}{4\pi\epsilon_0} \cdot \frac{P}{r^3} \cdot \sqrt{3 \cos^2 \theta + 1} \end{aligned} \quad \dots(2.9.6)$$

If the resultant field E_R makes an angle β with the direction of E_r , then

$$\tan \beta = \frac{E_\theta}{E_r} = \frac{1}{2} \tan \theta$$

$$\text{or } \beta = \tan^{-1} \left(\frac{1}{2} \tan \theta \right) \quad \dots(2.9.7)$$

The magnitude and direction of the far-field of a dipole at any point, defined by the polar coordinates (r, θ) are given by eqns. (2.9.6) and (2.9.7). These two eqns. can be used to get back the eqns. for electric field for two special cases as follows :

i) *Electric field strength at end-on position*

Putting $\theta = 0$ in eqn. (2.9.6) and (2.9.7) we have

$$E_R = \frac{1}{4\pi\epsilon_0} \cdot \frac{2P}{r^3}$$

and $\beta = \tan^{-1} 0 = 0^\circ$... (2.9.8)

The eqn. (2.9.8) is equivalent to \vec{E}_p of eqn. (2.9.2).

ii) **Electric field strength at broad side - on position**

Putting $\theta = 90^\circ$ in eqns. (2.9.6) and (2.9.7) we have

$$E_R = \frac{1}{4\pi \epsilon_0} \cdot \frac{P}{r^3}$$

and $\beta = \tan^{-1} \infty = 90^\circ$... (2.9.9)

The eqn. (2.9.9) is equivalent to \vec{E}_Q of eqn. (2.9.5).

An Alternative Method

(i) **End-on-Position :**

The electric field strength \vec{E} at a point P, is the vector sum of the electric field strengths due to charge -q at A and +q at B ; and is given

$$\begin{aligned} \text{as } \vec{E} &= \vec{E}_{-q} + \vec{E}_{+q} = \frac{1}{4\pi \epsilon_0} \left[\frac{(-q) \vec{AP}}{|\vec{AP}|^3} + \frac{(+q) \vec{BP}}{|\vec{BP}|^3} \right] \\ &= \frac{q}{4\pi \epsilon_0} \left[\frac{\vec{BP}}{|\vec{BP}|^3} - \frac{\vec{AP}}{|\vec{AP}|^3} \right] \end{aligned} \quad \dots (2.9.10)$$

Now (see fig. 2.4)

$$\vec{BP} = \vec{OP} - \vec{OB} = (r - \ell) \hat{x} \quad \dots (2.9.11)$$

$$\vec{AP} = \vec{OP} + \vec{AO} = (r + \ell) \hat{x} \quad \dots (2.9.12)$$

Giving $|\vec{BP}| = r - \ell, |\vec{AP}| = r + \ell$... (2.9.13)

Using eqns. 2.9.11, 2.9.12 and 2.9.13 in 2.9.10 we obtain.

$$\begin{aligned} \vec{E} &= \frac{q}{4\pi \epsilon_0} \left[\frac{1}{(r - \ell)^2} - \frac{1}{(r + \ell)^2} \right] \hat{x} \\ \vec{E} &= \frac{q}{4\pi \epsilon_0} \cdot \frac{4r\ell}{(r^2 - \ell^2)^2} \hat{x} = \frac{2r(2q\ell \hat{x})}{4\pi \epsilon_0 (r^2 - \ell^2)^2} \dots (2.9.14) \end{aligned}$$

Defining electric dipole moment $\vec{p} = 2q\ell \hat{x} = 2q\vec{\ell}$... (2.9.15)

We have

$$\vec{E} = \frac{2r\vec{p}}{4\pi \epsilon_0 (r^2 - \ell^2)^2} \quad \dots (2.9.16)$$

Since $r \gg \ell$, so $r^2 - \ell^2 \approx r^2$, and we have .

$$\vec{E} = \frac{1}{4\pi \epsilon_0} \cdot \frac{2\vec{p}}{r^3} \quad \dots (2.9.17)$$

ii) **Broad side-on-Position :**

Similarly we have (see fig. 2.5)

$$\vec{E} = \vec{E}_{-q} + \vec{E}_{+q} = \frac{q}{4\pi \epsilon_0} \left[\frac{\vec{BQ}}{|\vec{BQ}|^3} - \frac{\vec{AQ}}{|\vec{AQ}|^3} \right] \quad \dots (2.9.18)$$

Now $\vec{BQ} = \vec{BO} + \vec{OQ} = -\ell \hat{x} + r \hat{y}$... (2.9.19)

$$\vec{AQ} = \vec{AO} + \vec{OQ} = \ell \hat{x} + r \hat{y} \quad \dots (2.9.20)$$

Giving $|\vec{BQ}| = (r^2 + \ell^2)^{1/2} = |\vec{AQ}|$... (2.9.21)

Using 2.9.19, 2.9.20 and 2.9.21 in 2.9.18 we obtain.

$$\begin{aligned} \vec{E} &= \frac{q}{4\pi \epsilon_0} \left[\frac{-\ell \hat{x} + r \hat{y}}{(r^2 - \ell^2)^{3/2}} - \frac{\ell \hat{x} + r \hat{y}}{(r^2 + \ell^2)^{3/2}} \right] \\ &= \frac{q}{4\pi \epsilon_0} \cdot \frac{1}{(r^2 + \ell^2)^{3/2}} [-\ell \hat{x} + r \hat{y} - \ell \hat{x} - r \hat{y}] \end{aligned}$$

$$\vec{E} = \frac{q}{4\pi\epsilon_0} \frac{1}{(r^2 + \ell^2)^{3/2}} (-2\ell\hat{x}) \quad \dots(2.9.22)$$

Using (2.9.15) in 2.4.22, we obtain

$$\vec{E} = \frac{1}{4\pi\epsilon_0} \frac{(-\vec{p})}{(r^2 + \ell^2)^{3/2}} \quad \dots(2.9.23)$$

Since $r \gg \ell$, so $r^2 + \ell^2 \approx r^2$, and we have

$$\vec{E} = \frac{1}{4\pi\epsilon_0} \frac{(-\vec{p})}{r^3} \quad \dots(2.9.24)$$

iii) At a general point :

Similarly (see fig. 2.6) we have

$$\vec{E} = \vec{E}_{-q} + \vec{E}_{+q} = \frac{q}{4\pi\epsilon_0} \left[\frac{\vec{BR}}{|\vec{BR}|^3} - \frac{\vec{AR}}{|\vec{AR}|^3} \right] \quad \dots(2.9.25)$$

Now from fig. 2.6

$$\vec{BR} = \vec{BO} + \vec{OR} = -\ell\hat{x} + \vec{r} = \vec{r} - \vec{\ell} \quad \dots(2.9.26)$$

$$\vec{AR} = \vec{AO} + \vec{OR} = \ell\hat{x} + \vec{r} = \vec{r} + \vec{\ell} \quad \dots(2.9.27)$$

$$\text{Giving } |\vec{BR}| = (r^2 + \ell^2 - 2\vec{\ell}\cdot\vec{r})^{1/2} \quad \dots(2.9.28)$$

$$|\vec{AR}| = (r^2 + \ell^2 + 2\vec{\ell}\cdot\vec{r})^{1/2} \quad \dots(2.9.29)$$

Hence with $r \gg \ell$ and retaining upto order ℓ , we have

$$\frac{1}{|\vec{BR}|^3} = (r^2 + \ell^2 - 2\vec{\ell}\cdot\vec{r})^{-3/2} = r^{-3} \left(1 + \frac{3\vec{\ell}\cdot\vec{r}}{r^2} \right) \quad \dots(2.9.30)$$

$$\frac{1}{|\vec{AR}|^3} = (r^2 + \ell^2 + 2\vec{\ell}\cdot\vec{r})^{-3/2} = r^{-3} \left(1 - \frac{3\vec{\ell}\cdot\vec{r}}{r^2} \right) \quad \dots(2.9.31)$$

Using 2.9.26 to 3.9.31 in 2.9.25 we obtain.

$$\vec{E} = \frac{q}{4\pi\epsilon_0} \frac{1}{r^3} \left[(\vec{r} - \vec{\ell}) \left(1 + \frac{3\vec{\ell}\cdot\vec{r}}{r^2} \right) - (\vec{r} + \vec{\ell}) \left(1 - \frac{3\vec{\ell}\cdot\vec{r}}{r^2} \right) \right]$$

Giving (retaining up to order ℓ)

$$= \frac{q}{4\pi\epsilon_0} \frac{1}{r^3} \left[\frac{6(\vec{\ell}\cdot\vec{r})\vec{r}}{r^2} - 2\vec{\ell} \right] \quad \dots(2.9.32)$$

Now the component along \vec{r} is

$$E_r = \hat{r}\cdot\vec{E} = \frac{q}{4\pi\epsilon_0} \frac{1}{r^3} \frac{4\vec{\ell}\cdot\vec{r}}{r}$$

$$E_r = \frac{1}{4\pi\epsilon_0} \frac{1}{r^3} \frac{2\vec{p}\cdot\vec{r}}{r} = \frac{2p_r}{4\pi\epsilon_0 r^3} \quad \dots(2.9.33)$$

$$\text{Where } p_r = \vec{p}\cdot\frac{\vec{r}}{r} = \vec{p}\cdot\hat{r} = p \cos \theta \quad \dots(2.9.34)$$

$$\therefore E_r = \frac{2p \cos \theta}{4\pi\epsilon_0 r^3} \quad \dots(2.9.35)$$

The component along increasing θ -dir is

$$E_\theta = \hat{\theta}\cdot\vec{E} = \frac{q}{4\pi\epsilon_0} \frac{1}{r^3} (-2\vec{\ell}\cdot\hat{\theta})$$

$$E_\theta = \hat{\theta}\cdot\vec{E} = \frac{1}{4\pi\epsilon_0} \frac{(-\vec{p}\cdot\hat{\theta})}{r^3} = \frac{(-p_\theta)}{4\pi\epsilon_0 r^3} \quad \dots(2.9.36)$$

where $p_\theta = \vec{p}\cdot\hat{\theta} = p \cos(90+\theta) = p \sin \theta$

$$\therefore E_\theta = \frac{p \sin \theta}{4\pi\epsilon_0 r^3} \quad \dots(2.9.37)$$

From (2.9.35) and (2.9.37) we obtain

$$E_\theta = \sqrt{E_r^2 + E_\theta^2} = \frac{1}{4\pi\epsilon_0} \frac{p}{r^3} \sqrt{3\cos^2 \theta + 1} \quad \dots(2.9.38)$$

2.10 Electric dipole in a uniform electric field

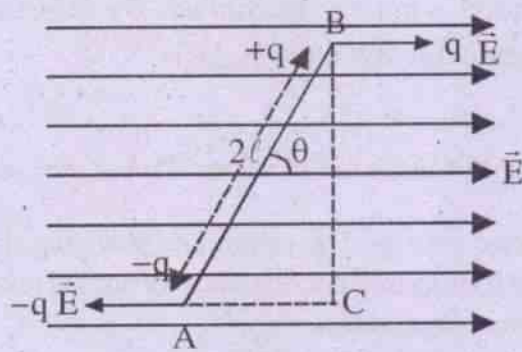

Fig. 2.7

Consider an electric dipole AB, of dipole moment \vec{P} , situated in a uniform electric field \vec{E} such that its dipole moment \vec{P} makes an angle θ with \vec{E} . +q charge of the dipole experiences a force $q\vec{E}$ while -q experiences a force $-q\vec{E}$. These two forces, equal in magnitude and opposite in directions produce a couple. The torque of the couple is

$$\begin{aligned} T &= BC \times qE \\ &= 2l \sin \theta \times qE \quad (\because BC = 2l \sin \theta) \\ &= PE \sin \theta \dots(2.10.1) \quad (\because P = 2ql) \end{aligned}$$

This torque has a tendency to rotate the dipole making it align parallel to the electric field \vec{E} . Eqn. (2.10.1) can be expressed in vector forms as

$$\vec{T} = \vec{P} \times \vec{E} \dots(2.10.2)$$

2.11 Work done in rotating an electric dipole in a uniform electric field :

The torque acting on an electric dipole in a uniform electric field E is given by eqn. (2.11.1) as

$$T = PE \sin \theta$$

where θ is the angle between \vec{E} and \vec{P} (refer fig. 2.7)

If the dipole is further rotated through an infinitesimal angle $d\theta$ from θ , the work done is

$$\begin{aligned} dw &= Td\theta \\ &= PE \sin \theta d\theta \end{aligned}$$

Hence work done (by an external agent) in rotating the electric dipole in the electric field through an angle θ from its equilibrium position is

$$\begin{aligned} \int_0^w dw &= \int_0^\theta PE \sin \theta \\ W &= PE(1 - \cos \theta) \dots(2.11.1) \end{aligned}$$

Work done in rotating the dipole from the angle θ_1 to θ_2 w.r.t equilibrium position is

$$\begin{aligned} W &= \int_{\theta_1}^{\theta_2} PE \sin \theta \\ &= PE(\cos \theta_1 - \cos \theta_2) \dots(2.11.2) \end{aligned}$$

2.12 Electric potential energy of an electric dipole in an electric field :

Electric potential energy of an electric dipole in an electric field when it is parallel to electric field is

$$U_0 = -PE \dots(2.13.1)$$

In this position the dipole is in stable equilibrium and it has minimum potential energy. Negative sign shows that the dipole forms a bound system in the electric field.

If the dipole is rotated through an angle θ from equilibrium position, work done on it is

$$W = PE(1 - \cos \theta) \quad (\text{Refer eqn. 2.12.1})$$

Hence electric potential energy of the dipole when it is oriented at an angle θ to the electric field is

$$\begin{aligned}
 U &= U_0 + PE(1 - \cos \theta) \\
 &= -PE + PE(1 - \cos \theta) \\
 &= -PE \cos \theta \\
 &= -\vec{P} \cdot \vec{E} \quad \dots(2.13.2)
 \end{aligned}$$

2.13 Electric flux :

Flux is the property of a vector field. The surface integral of a vector field over a given surface gives flux of the vector field through that surface.

The word flux means flow which is adopted from hydrodynamics. We cannot think of anything that is actually flowing in case of electric and magnetic fields. Still the term flux is used for these vector fields.

The electric flux associated with electric field is a measure of total number of electric lines of force passing normally through the surface held in the field. It is represented by ϕ .

The concept of electric flux ϕ , will lead us to the development of Gauss's theorem.

The electric flux through an elementary area ΔS is defined as the product of the area and the component of electric field strength normal to that area. In this definition, electric field must be uniform over the entire elementary area ΔS .

Let \vec{E} be the electric field strength over the elementary area ΔS . Component of electric field strength in the direction of the normal to the area is $E_n = E \cos \theta = \vec{E} \cdot \hat{n}$

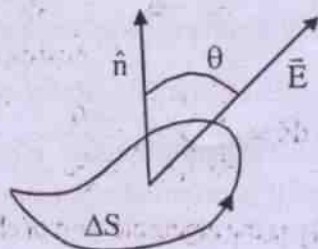

Fig. 2.8

where \hat{n} is the unit vector in the direction of positive normal to the surface. By definition electric flux $\Delta\phi$ through ΔS is

$$\Delta\phi = \vec{E} \cdot \hat{n} \Delta S \quad \dots(2.13.1)$$

To make use of vector algebra, consider

vector area $\vec{\Delta S}$. Its magnitude gives the area and its direction is along positive normal to the area of the surface.

For closed surfaces, conventionally, normal directed outward is taken as positive.

For open surfaces, direction of positive normal and tracing of the boundary enclosing the surface are related by right-handed screw rule as illustrated in the fig. 2.8.

We can now write the eqn. (2.13.1) as

$$\Delta\phi = \vec{E} \cdot \vec{\Delta S} \quad \dots(2.13.2)$$

Electric flux through a closed surface can be expressed in integral form as

$$\phi = \oint \vec{E} \cdot d\vec{S} \quad \dots(2.13.3)$$

The circle over the integral sign represents an integration over a closed surface.

2.14 Gauss's law and its proof :

The flux through a surface is measured by the lines of force that cut through it. Number of lines of force originating from a charge depends on its net amount. The law relates the flux through any closed surface and the net charge enclosed by the surface.

Gauss's law states that the flux of electric field \vec{E} through any closed surface is equal to the net charge q enclosed by the surface divided by ϵ_0 .

Mathematically, Gauss's law can be expressed as

$$\oint \vec{E} \cdot d\vec{S} = \frac{q}{\epsilon_0} \quad \dots(2.14.1)$$

It is interesting to note that electric field on the left hand side of the eqn. (2.14.1) is the resultant electric field due to all the charges existing in the space, whereas the charge appearing on the right hand side includes only those which are inside the closed surface.

i) Flux due to an internal charge :

Consider a point charge q at 'O' inside a hypothetical closed surface S of an arbitrary shape.

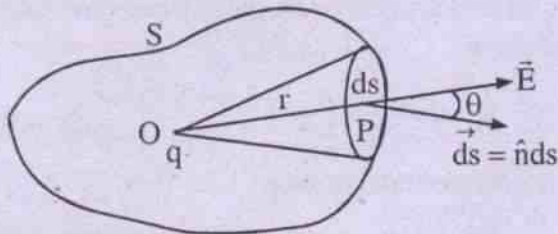

Fig. 2.9

Let P be a point on the surface at a distance r from the point 'O' and ds be an infinitesimal element of the surface S around the point P.

Electric field intensity at the point P due to the charge q is

$$E = \frac{1}{4\pi \epsilon_0} \cdot \frac{q}{r^2} \text{ directed along the line OP.}$$

Let extended line OP make an angle θ with the outward normal to dS . The flux of the electric field $d\phi$ through dS is

$$\begin{aligned} d\phi &= \vec{E} \cdot d\vec{S} = E \cdot \hat{n} ds \\ &= E ds \cos \theta \\ &= \frac{1}{4\pi \epsilon_0} \cdot \frac{q}{r^2} ds \cos \theta \\ &= \frac{q}{4\pi \epsilon_0} \cdot \frac{ds \cos \theta}{r^2} \\ &= \frac{q}{4\pi \epsilon_0} d\Omega \end{aligned} \quad \dots(2.14.2)$$

where $\frac{ds \cos \theta}{r^2} = d\Omega$ is the solid angle

subtended by the area ds at the internal point 'O'. The total flux through the entire closed surface is

$$\begin{aligned} \phi &= \oint \frac{q}{4\pi \epsilon_0} d\Omega \\ &= \frac{q}{4\pi \epsilon_0} \oint d\Omega \\ &= \frac{q}{4\pi \epsilon_0} \Omega \quad \dots(2.14.3) \\ &= \frac{q}{4\pi \epsilon_0} \cdot 4\pi \end{aligned}$$

$$\text{Hence } \phi = \oint \vec{E} \cdot d\vec{s} = \frac{q}{\epsilon_0} \quad \dots(2.14.4)$$

where Ω is the total solid angle subtended by the closed surface S at an internal point 'O' and it is equal to 4π .

Derivation of eqn. (2.14.4) is the proof of Gauss's law for a single point charge q . However, the law holds good even if there are n point charges enclosed by the surface S . This is because, we know from the principle of superposition that the electric field due to a number of charges is the vector sum of their individual fields. Hence the flux through the surface S when the electric field \vec{E} produced by n point charges q_1, q_2, \dots, q_n enclosed by it is given by

$$\begin{aligned} \oint \vec{E} \cdot d\vec{s} &= \oint (\vec{E}_1 + \vec{E}_2 + \dots + \vec{E}_n) \cdot d\vec{s} \\ &= \oint \vec{E}_1 \cdot d\vec{s} + \oint \vec{E}_2 \cdot d\vec{s} + \dots + \oint \vec{E}_n \cdot d\vec{s} \\ &= \frac{q_1}{\epsilon_0} + \frac{q_2}{\epsilon_0} + \dots + \frac{q_n}{\epsilon_0} \end{aligned} \quad \text{(using eqn.2.14.4)}$$

$$\oint \vec{E} \cdot d\vec{s} = \frac{1}{\epsilon_0} \sum_{j=1}^n q_j = \frac{q}{\epsilon_0} \quad \dots(2.14.5)$$

where $\sum q_j$ is the algebraic sum of charges and is equal to net charge q enclosed by the surface S .

ii) **Flux due to an external charge :**

Let the point charge q be placed at the point 'O' outside the closed surface S . Let us cut the surface by a cone subtending a very small solid angle $d\Omega$ at o by the cut areas ds_1 , ds_2 , ds_3 and ds_4 , surrounding the points P, Q, R and T respectively as shown in the fig. (2.10). Electric flux along an outward drawn normal is positive,

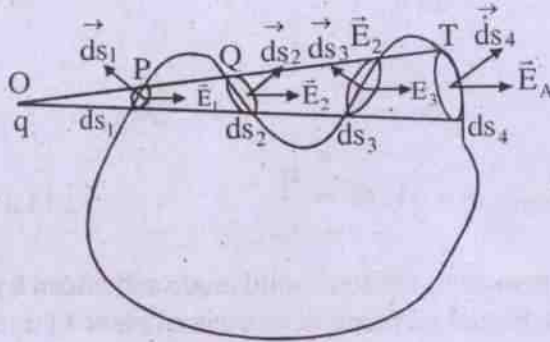

Fig. 2.10

while for an inward drawn normal it is negative. Hence the electric flux through the small areas ds_2 and ds_4 is positive while it is negative through the areas ds_1 and ds_3 . Thus

electric flux at P through the area $ds_1 =$

$$-\frac{q}{4\pi\epsilon_0}d\Omega$$

electric flux at Q through the area $ds_2 =$

$$\frac{q}{4\pi\epsilon_0}d\Omega$$

electric flux at R through the area $ds_3 =$

$$-\frac{q}{4\pi\epsilon_0}d\Omega$$

and electric flux at T through the area $ds_4 =$

$$\frac{q}{4\pi\epsilon_0}d\Omega$$

Therefore, the total electric flux

$$= -\frac{q}{4\pi\epsilon_0}d\Omega + \frac{q}{4\pi\epsilon_0}d\Omega - \frac{q}{4\pi\epsilon_0}d\Omega + \frac{q}{4\pi\epsilon_0}d\Omega = 0$$

The above reasoning is true for all the cones drawn from 'O' through any shape of the surface. Hence, the total electric flux through the whole surface due to an external charge is zero. As there is no charge within the surface, according to Gauss's law also, the total electric flux through the whole surface is zero.

Thus Gauss's law, in general, is proved.

If the closed surface encloses a continuous charge distribution of volume density ρ and volume of the charge \mathcal{V} , then Gauss's law takes the form,

$$\oint \vec{E} \cdot d\vec{s} = \frac{1}{\epsilon_0} \int \rho d\mathcal{V} \quad \dots(2.14.6)$$

2.15 Gaussian surface :

It is an imaginary surface so constructed that at every point of it the direction of electric field vector is known in advance so that Gauss's law can readily be applied. For example Gaussian surface considered for :

- i) a point charge is spherical surface of any radius with the point charge as centre.
- ii) a line charge is cylindrical surface of any radius coaxial with the line charge and so on.

2.16 Applications of Gauss's law :

a) **Field due to point charge : Derivation of coulomb's law :**

Consider a point charge at the point 'O'. Applying Gauss's law, let us calculate electric field at a point p at a distance r from the point charge q . Suitable Gaussian surface to be chosen here is a spherical surface of radius r centred on the charge q . (fig. 2.10 a)

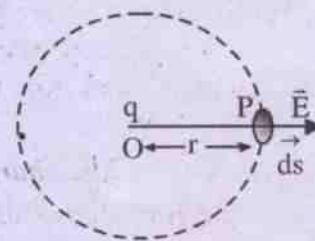

Fig. 2.10 (a)

It is obvious that at every point of the surface, \vec{E} is normal to the surface and has same magnitude. \vec{E} and $d\vec{s}$ are in the same direction as they are radially outward at every point of the Gaussian surface.

Applying Gauss's law, we have

$$\oint \vec{E} \cdot d\vec{s} = \frac{q}{\epsilon_0}$$

$$\oint E ds \cos \theta = \frac{q}{\epsilon_0}$$

Since $\theta = 0^\circ$ and magnitude of E is constant at all points of the surface,

$$E \oint ds = \frac{q}{\epsilon_0}$$

or
$$E \cdot 4\pi r^2 = \frac{q}{\epsilon_0}$$

because $\oint ds = 4\pi r^2$ is the total surface area of the sphere of radius r .

Hence
$$E = \frac{1}{4\pi \epsilon_0} \cdot \frac{q}{r^2} \quad \dots(2.16.1)$$

Now consider another point charge q' at P in the electric field E due to the charge q which is calculated above (eqn. 2.16.1). The force F that acts on the charge q' is

$$F = q' E = \frac{1}{4\pi \epsilon_0} \cdot \frac{qq'}{r^2}$$

The direction of the force F is in the direction of \vec{E} which is along the radius vector drawn from q to q' if both q and q' are positive charges, i.e., the force F is a repulsive force. Thus Coulomb's law is derived from Gauss's law.

b) Electric field due to a line charge :

Consider a long line charge having a uniform linear charge density λ (charge per unit

length). We have to calculate the electric field at a point P which is at a distance r from the line charge.

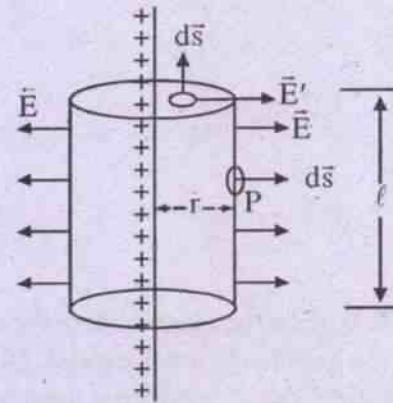

Fig. 2.11

Let us choose a cylinder of radius r and length l passing through the point P coaxial with the line charge as the closed Gaussian surface as shown in fig (2.11)

For flat circular caps of the cylinder, the electric field vector \vec{E} and area vector $d\vec{s}$ are at right angles to each other. Hence $\int \vec{E} \cdot d\vec{s} = 0$ over the two flat circular caps. Total electric flux through the closed gaussian surface is, therefore, due to curved surface of the cylinder only. On this surface, at all points, \vec{E} is perpendicular to it and parallel to $d\vec{s}$. Again magnitude of \vec{E} at all points of the curved surface is same.

Hence using Gauss's law, we have

$$\oint \vec{E} \cdot d\vec{s} = \frac{q}{\epsilon_0}$$

$$\int_{\text{curved surface}} \vec{E} \cdot d\vec{s} + \int_{\text{flat surfaces}=0} \vec{E} \cdot d\vec{s} = \frac{q}{\epsilon_0}$$

$$\therefore \int_{\text{curved surface}} E \cdot ds \cos \theta = \frac{q}{\epsilon_0}$$

$$E \int ds = \frac{q}{\epsilon_0}$$

Since area of the curved surface of the cylinder is $2\pi r\ell$ and charge enclosed by the cylinder is $q = \lambda\ell$,

$$E \cdot 2\pi r\ell = \frac{\lambda\ell}{\epsilon_0}$$

$$\text{or } E = \frac{\lambda}{2\pi\epsilon_0 r} \quad \dots(2.16.2)$$

Eqn. (2.16.2) gives the magnitude of the electric field due to a line charge at a distance r . Direction of electric field due to a positive line charge is radially outward whereas due to a negative line charge it is radially inwards i.e. towards the line charge.

c) **Electric field due to an infinite plane sheet of charge :**

Consider a thin infinite plane sheet of charge, having a uniform surface charge density σ on both sides (in a thin sheet of charge same charge shows up on both sides). Symmetry of the problem indicates that the electric field is uniform and must be perpendicular to the plane sheet of charge. Further, electric fields at the points lying on opposite sides of the sheet and equidistant from it, must be equal and opposite.

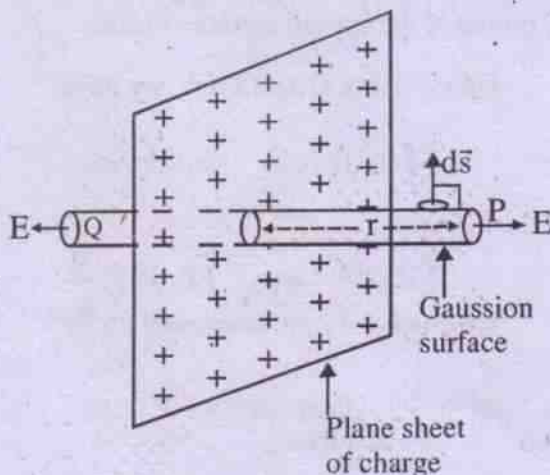

Fig. 2.12

To calculate electric field due to the plane sheet of charge at any point P at a distance r from it, let us choose a cylinder of area of cross section A and length $2r$ through the point P piercing the plane sheet of charge as the Gaussian surface as shown in the fig. (2.12).

Electric flux through the curved surface of the Gaussian surface is zero since area vector $d\vec{s}$ is perpendicular to the curved surface while electric field \vec{E} is parallel to it. The electric flux is only due to two flat circular caps of the cylinder. The charge enclosed by the Gaussian surface is σA . Now applying Gauss's law, we have

$$\oint \vec{E} \cdot d\vec{s} = \frac{q}{\epsilon_0}$$

$$\int_{\text{curved surface}} \vec{E} \cdot d\vec{s} + \int_{\text{first cap}} \vec{E} \cdot d\vec{s} + \int_{\text{second cap}} \vec{E} \cdot d\vec{s} = \frac{\sigma A}{\epsilon_0}$$

(=0)

$$\text{or } E \int ds + E \int ds = \frac{\sigma A}{\epsilon_0}$$

$$\text{or } EA + EA = \frac{\sigma A}{\epsilon_0}$$

$$\text{or } E = \frac{\sigma}{2\epsilon_0} \quad \dots(2.16.3)$$

It is important to note here, in case of an infinite plane thin charged conductor, the Gaussian surface will enclose a charge $2\sigma A$ (σA on each side of the conductor)

Using the eqn. (2.16.3), the electric field due to an infinite plane, thin charged conductor is

$$E = \frac{2\sigma}{2\epsilon_0} = \frac{\sigma}{\epsilon_0} \quad \dots(2.16.4)$$

d) **Electric field between two oppositely charged parallel plates (parallel plate capacitor) :**

Consider two parallel infinite plates, uniformly charged with surface charge densities $+\sigma$ and $-\sigma$ respectively. The electric field

between such oppositely charged parallel plates is uniform as shown in the fig. 2.13.

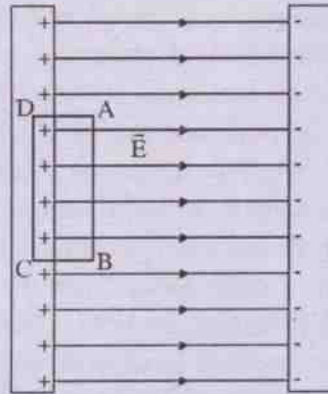

Fig. 2.13

Here the Gaussian surface is a rectangular box. Only one of the faces AB of the rectangular box ABCD, inside the electric field contributes to the flux. Flux over the other faces is zero. Since charge enclosed by the rectangular box is σA , we have from Gauss's law

$$\oint \vec{E} \cdot d\vec{s} = \frac{q}{\epsilon_0}$$

$$\int_{AB} \vec{E} \cdot d\vec{s} + \int_{BC} \vec{E} \cdot d\vec{s} + \int_{CD} \vec{E} \cdot d\vec{s} + \int_{DA} \vec{E} \cdot d\vec{s} = \frac{\sigma A}{\epsilon_0}$$

$$E \int_{AB} ds = \frac{\sigma A}{\epsilon_0}$$

$$EA = \frac{\sigma A}{\epsilon_0}$$

$$E = \frac{\sigma}{\epsilon_0} \quad \dots(2.16.5)$$

where A is the area of the face AB. $\int_{CD} \vec{E} \cdot d\vec{s} = 0$

because electric field E is zero inside a charged conductor.

Electric Potential :

We have seen that in order to calculate Coulomb interaction between a number of charges, one has to use the principle of

superposition. This approach poses a mathematical difficulty since it involves addition of a large number of vector quantities. One desires to have a scalar function in terms of which electric field can be expressed. Such an approach becomes very simple because the scalar function is much easier to compute than vector fields. Fortunately, the concept of electric potential provides us with such a scalar which is also related to the electric field. Let us now proceed to develop the concept of electric potential and its relation with electric field.

2.17 Conservative nature of electric field :

The conservative nature of electric field is the basis for the development of the concept of electric potential. A charge can be moved from one point to another in an electric field in a number of paths. But the work done is same in all paths. This path independent nature of the work done is known as conservative nature of electric field. It is expressed mathematically as

$$\oint \vec{E} \cdot d\vec{r} = 0 \quad \dots(2.17.1)$$

i.e. the work done in a closed path is zero. Here

\vec{E} is the electric field intensity at a point and $d\vec{r}$ is the infinitesimal displacement at the point. The relation is further explained as follows :

Let us consider an electric field due to a positive charge q as shown in the fig. (2.14). If a

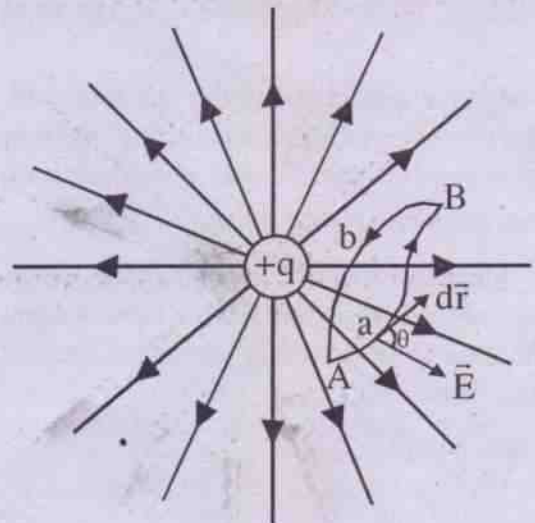

Fig. 2.14

test charge q_0 is displaced from A to B along the path AaB and is displaced back from B to A along the path BbA, no work is done. Mathematically

$$\int_A^B \vec{E} \cdot d\vec{r} + \int_B^A \vec{E} \cdot d\vec{r} = 0$$

(along the path AaB) (along the path Bba)

or

$$\int_A^B \vec{E} \cdot d\vec{r} = - \int_B^A \vec{E} \cdot d\vec{r}$$

or

$$\int_A^B \vec{E} \cdot d\vec{r} = \int_A^B \vec{E} \cdot d\vec{r}$$

(along the path AaB) (along the path AbB)

That is to say if the test charge is displaced from A to B, through the path AaB or AbB work done is same. In general, we can say, in displacing a charge from one point to another in an electric field in all possible paths work done is same. This concept is similar to conservative nature of gravitational field.

2.18 Electric potential energy :

Let an external agent be used to do work in moving a positive test charge q_0 from A to B in an arbitrary electric field against the field. The work done in the process is

$$W = - \int_A^B q_0 (\vec{E} \cdot d\vec{r}) \quad \dots(2.18.1)$$

The negative sign is due to the fact that work done by the external agent is equal and opposite to the work of electrical forces when there is no change in kinetic energy of q_0 .

Since there is no change in kinetic energy of a test charge, the external work done is equal to the change in potential energy of the test charge. Thus

$$(P.E)_B - (P.E)_A = - \int_A^B q_0 (\vec{E} \cdot d\vec{r}) \quad \dots(2.18.2)$$

Eqn. (2.18.2) is the general expression for the difference between the potential energies of the test charge q_0 at points A and B in an electric field. To define potential energy of a charge at a point in an electric field, rather than potential energy difference, we have to choose a reference point where the potential energy is arbitrarily considered as zero. For mathematical simplicity, this reference point is chosen at infinity. Thus a test charge is considered to have zero potential energy when it is far away from the source charge which produces the field. Thus in eqn. (2.18.2) if the point A is considered to be at infinity so that $(P.E)_A = 0$ and hence we have

$$(P.E)_B = - \int_{\infty}^B q_0 (\vec{E} \cdot d\vec{r}) \quad \dots(2.18.3)$$

Since B can be any point in the electric field, we can replace the subscripts in the integral to have a general expression for potential energy of a test charge q_0 in an electric field as

$$P.E = - \int_{\infty}^r q_0 (\vec{E} \cdot d\vec{r}) \quad \dots(2.18.4)$$

where it is automatically understood that the integral is a line integral along a line from infinity to the point in question. The potential energy as defined in eqn. (2.18.4) has a unique value at a given point because of the conservative nature of electric field.

It is worth mentioning here that the potential energy is really a property of a system of charges (test charge and charges setting up the field). Customarily we talk of potential energy of a test charge assuming the presence of source charges.

Now we are in a position to define the potential energy of a charge and a system of charges.

The potential energy of a charge at a point in an electric field is defined as the work done by an external agent in bringing the charge

from infinity to that point against the electric field.

- The potential energy of a system of charges is defined as the work done by an external agent (against the electric field) to assemble them by bringing from infinity to form the system.

2.19 Electrostatic Potential :

We have defined that in an electric field, the potential energy of a charge at a point has a unique value if we choose the potential energy to be zero at infinity. Obviously potential energy per unit charge at a point has also a unique value and it is a scalar. This scalar point function is called as electrostatic potential or simply electric potential.

The electrostatic potential at a point in an electric field is defined as the work per unit charge required to bring a positive charge from infinity to that point against the electric field. Thus potential is a scalar quantity and it can be positive or negative.

Mathematical expression for the potential (V) at a point using eqn. (2.18.4) can be written as

$$V = \frac{W}{q_0} = - \int_{\infty}^{\vec{r}} \vec{E} \cdot d\vec{r} \quad \dots(2.19.1)$$

In terms of line integral, electrostatic potential at any point in an electric field is defined as negative of line integral of the electric field intensity from infinity to that point along any path.

If r is the distance of a point from a point source field, the potential at that point can explicitly be written in line integral form as

$$V(r) = - \int_{\infty}^{\vec{r}} \vec{E} \cdot d\vec{r} \quad \dots(2.19.2)$$

2.20 Potential difference :

The potential difference between two points in an electric field is defined as the

potential energy difference between these points per unit charge.

From eqn. (2.18.2), we have the potential difference as

$$\frac{(P.E)_B - (P.E)_A}{q_0} = - \int_A^B \vec{E} \cdot d\vec{r} \quad \dots(2.20.1)$$

$$\text{But } \frac{(P.E)_B}{q_0} = V_B \text{ and } \frac{(P.E)_A}{q_0} = V_A$$

where V_B and V_A are the potentials at points B and A respectively. Hence potential difference between the points B and A is

$$V_B - V_A = - \int_A^B \vec{E} \cdot d\vec{r} \quad \dots(2.21.2)$$

The potential difference between two points B and A is defined as the negative line integral of electric field intensity from the point A to the point B.

Alternatively, the potential difference between any two points in an electric field is defined as the work done in taking a unit positive charge from one point to other against the electric field.

2.21 Zero reference potential :

For mathematical convenience, a point at infinity with respect to source charge is considered to be at zero potential. This choice is suitable for electrostatics. For electrical circuits, the above reference point for zero potential is inconvenient and potential of the earth is chosen as the zero potential. This choice is made because the potential of the earth remains constant even though it may gain or lose electricity.

Positive potential :

A conductor is said to be at positive potential if when it is connected to earth, positive charge flows from the conductor to earth i.e. electrons flow from earth to the conductor.

Negative potential :

A conductor is said to be at negative potential if when it is connected to earth, positive charge flows from earth to conductor i.e. electrons flow from conductor to earth.

Zero potential :

A conductor is said to be at zero potential if when it is connected to earth, no charge flows from conductor to earth or vice versa i.e. earth connected conductor is at zero potential.

2.22 Units of electric potential (V) and relation between them :

In SI system

$$V = \frac{W}{q} = \frac{\text{Joule}}{\text{Coulomb}} = \text{Volt}$$

In c.g.s. (esu)

$$V = \frac{W}{q} = \frac{\text{erg}}{\text{Stat-Coulomb}} = \text{statvolt}$$

In c.g.s. (emu)

$$V = \frac{W}{q} = \frac{\text{erg}}{\text{ab-Coulomb}} = \text{ab-volt}$$

Relation between volt, stat volt and ab-volt

$$1 \text{ volt} = \frac{1 \text{ Joule}}{1 \text{ Coulomb}} = \frac{10^7 \text{ erg}}{3 \times 10^9 \text{ Coulomb}} = \frac{1}{300} \text{ stat-volt}$$

Again

$$1 \text{ volt} = \frac{1 \text{ Joule}}{1 \text{ Coulomb}} = \frac{10^7 \text{ erg}}{\frac{1}{10} \text{ ab-Coulomb}} = 10^8 \text{ ab-volt}$$

Hence stat volt = 300 volt = 3×10^{10} ab-volt.

Volt :

Potential at any point in an electric field is said to be one volt if one Joule of work is done in bringing 1 Coulomb of charge from infinity to that point.

It is also defined as follows :

P.d. between two points in an electric field is said to be one volt if one Joule of work is done in taking one Coulomb of charge from

one point to the other. Similarly we can define for stat-volt and ab-volt.

2.23 Dimensions of electric potential :

$$[V] = \frac{[\text{Joule}]}{[\text{Coulomb}]}$$

$$= \frac{[\text{ML}^2\text{T}^{-2}]}{[Q]} = [\text{ML}^2\text{T}^{-2}\text{Q}^{-1}]$$

$$= \frac{[\text{ML}^2\text{T}^{-2}]}{[\text{AT}]} = [\text{ML}^2\text{T}^{-3}\text{A}^{-1}]$$

Dimensions of electric potential are

$$[\text{ML}^2\text{T}^{-2}\text{Q}^{-1}] \text{ or } [\text{ML}^2\text{T}^{-3}\text{A}^{-1}]$$

2.24 Electron Volt :

It is a unit of energy, frequently used in modern physics and electronics. *An electron volt (eV) is defined as the energy acquired by an electron or a proton in a potential difference of one volt.*

In general, energy acquired by a charge q in a potential difference of V is given by

$$\text{electric energy} = Vq$$

$$\therefore 1 \text{ ev} = 1 \times 1.6 \times 10^{-19} \text{ volt.Coulomb}$$

$$1 \text{ ev} = 1.6 \times 10^{-19} \text{ Joule} \quad \dots(2.24.1)$$

Electron volt being a very small unit, million-electron-volt (Mev) is used

$$1 \text{ Mev} = 10^6 \text{ ev} = 1.6 \times 10^{-13} \text{ Joule} \quad \dots(2.24.2)$$

Velocity (ϑ) acquired by an electron or a proton, initially at rest, in a p.d. of V is given by

$$\frac{1}{2} m \vartheta^2 = eV$$

$$\text{or } \vartheta = \sqrt{\frac{2eV}{m}} \quad \dots(2.24.3)$$

where m is the mass of the electron.

Example 2.24.1 Find the velocity acquired by an electron in a p.d. of 1 volt if it starts from rest. ($m_e = 9.1 \times 10^{-31}$ kg)

Solution :

Velocity acquired by an electron in a p.d. of V volts is

$$q = \sqrt{\frac{2ev}{m}} = \sqrt{\frac{2 \times 1.6 \times 10^{-19} \times 1}{9.1 \times 10^{-31}}} = 5.93 \times 10^5 \text{ ms}^{-1}$$

Example 2.24.2 What is the energy acquired by an α -particle in a potential difference of 5 volts in eV and Joule.

Solution :

$$\begin{aligned} \text{Energy acquired} &= Vq \\ &= 5 \times 2e = 10 \text{ eV} \\ &= 10 \times 1.6 \times 10^{-19} \\ &= 16 \times 10^{-19} \text{ J} \end{aligned}$$

α -particle acquires an energy of 10 eV or 16×10^{-19} J in a p.d. of 5 volt.

2.25 Electric potential due to a point charge:

Let q be a point charge placed at the point O. We want to find the potential V_p at a point P which is at a distance r from the charge q . Consider another point Q very close to P at a distance dr from P.

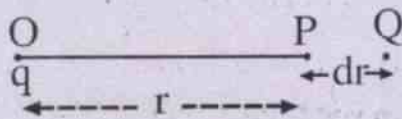

Fig. 2.15

By definition $V_p = -\int_{\infty}^r \vec{E} \cdot d\vec{r}$

where \vec{E} is the electric field at P due to the point charge q and

$$\vec{E} = \frac{1}{4\pi \epsilon_0} \cdot \frac{q}{r^2} \hat{r}$$

$$\begin{aligned} \therefore V_p &= -\int_{\infty}^r \frac{1}{4\pi \epsilon_0} \cdot \frac{q}{r^2} \cdot d\vec{r} \\ &= -\frac{q}{4\pi \epsilon_0} \int_{\infty}^r \frac{dr}{r^2} \quad (\because \hat{r} \cdot d\vec{r} = dr) \\ &= -\frac{q}{4\pi \epsilon_0} \left[-\frac{1}{r} \right]_{\infty}^r \\ &= \frac{q}{4\pi \epsilon_0} \cdot \frac{1}{r} \quad \dots(2.25.1) \end{aligned}$$

If the point charge q and the point P are in a dielectric medium of dielectric constant K , the potential is

$$V_p = \frac{1}{4\pi \epsilon_0 K} \cdot \frac{q}{r} \quad \dots(2.25.2)$$

2.26 Principle of superposition of potentials:

It states that potential at a point due to a group of charges is equal to scalar sum of potentials due to all individual charges constituting the group. The potential due to each charge is calculated as if other charges were not present.

Let us apply the principle to calculate electrostatic potential due to a system of charges.

2.27 Potential due to a system of charges :

Consider a system consisting of a group of point charges q_1, q_2, \dots, q_n . Potential at a point, which is at distances r_1, r_2, \dots, r_n from q_1, q_2, \dots, q_n respectively is given by the principle of superposition of potentials as

$$\begin{aligned} V &= V_1 + V_2 + \dots + V_n \\ &= \frac{1}{4\pi \epsilon_0} \left[\frac{q_1}{r_1} + \frac{q_2}{r_2} + \dots + \frac{q_n}{r_n} \right] \\ &= \frac{1}{4\pi \epsilon_0} \sum_{i=1}^n \frac{q_i}{r_i} \quad \dots(2.27.1) \end{aligned}$$

Eqn. (2.27.1) is written for a continuous distribution of charge by replacing the sum by an integral as :

$$V = \int dV = \frac{1}{4\pi\epsilon_0} \int \frac{dq}{r} \quad \dots(2.27.2)$$

where dq is a differential element of the charge distribution and r is the distance of the point at which the potential V is to be calculated from the charge distribution.

If the charge is distributed linearly, this

eqn. (2.27.2) takes the form
$$V = \frac{1}{4\pi\epsilon_0} \int \frac{\lambda d\ell}{r}$$

where λ is the charge per unit length or linear density of charge and $d\ell$ is the small element of length. For surface and volume distribution of charges the eqn. (2.27.2) takes form respectively as

$$V = \frac{1}{4\pi\epsilon_0} \int_{\text{surface}} \frac{\sigma ds}{r}$$

and
$$V = \frac{1}{4\pi\epsilon_0} \int_{\text{volume}} \frac{\rho dv}{r}$$

where σ and ρ are surface and volume charge densities, ds and dv are small elements of surface and volume respectively.

If the potential is to be calculated by a set of point charges and by volume, surface and line charge distributions, then using the principle of superposition, we can write

$$V = \frac{1}{4\pi\epsilon_0} \sum_{i=1}^n \frac{q_i}{r_i} + \frac{1}{4\pi\epsilon_0} \int_{\text{volume}} \frac{\rho dv}{r} + \frac{1}{4\pi\epsilon_0} \int_{\text{surface}} \frac{\sigma ds}{r} + \frac{1}{4\pi\epsilon_0} \int_{\text{line}} \frac{\lambda d\ell}{r} \quad \dots(2.27.3)$$

2.28 Electrostatic potential due to an electric dipole :

i) At a point in the end on position :

Consider AB an electric dipole consisting of two charges $-q$ and $+q$ at A and B respectively separated by a distance 2ℓ . Let P be a point on the dipole axis at a distance r from the mid point 'O' of the dipole. Using the principle of superposition of potentials leading to eqn. (2.27.1), for the dipole, the potential

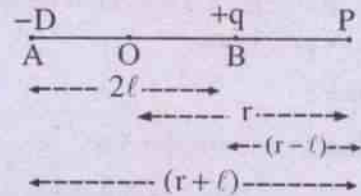

Fig. 2.20

at P in the end on position is

$$\begin{aligned} V_p &= \frac{1}{4\pi\epsilon_0} \sum_{i=1}^n \frac{q_i}{r_i} \\ &= \frac{1}{4\pi\epsilon_0} \left[\frac{q}{r-l} + \frac{-q}{r+l} \right] \\ &= \frac{1}{4\pi\epsilon_0} \cdot \frac{2q\ell}{(r^2 - \ell^2)} \\ &= \frac{1}{4\pi\epsilon_0} \cdot \frac{P}{(r^2 - \ell^2)} \quad \dots(2.28.1) \end{aligned}$$

where $P = 2q\ell$ is the magnitude of the dipole moment. For a dipole $\ell \ll r$, ℓ^2 can be neglected in comparison with r^2 and the eqn. (2.28.1) reduces to

$$V_p = \frac{1}{4\pi\epsilon_0} \cdot \frac{P}{r^2} \quad \dots(2.28.2)$$

ii) At a point in the broad side on position

Consider a point Q, on the perpendicular bisector of the dipole, at a distance r from the mid point O of the dipole. The potential at Q (broad side on position of the dipole) is

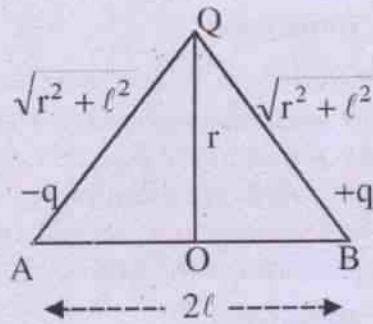

Fig. 2.21

$$V_Q = \frac{1}{4\pi \epsilon_0} \left[\frac{q}{\sqrt{r^2 + l^2}} + \frac{-q}{\sqrt{r^2 + l^2}} \right] = 0$$

Electrostatic potential at any point on the perpendicular bisector of electric dipole is zero.

iii) At any point due to an electric dipole

Let R be any point at a distance r from the mid point 'O' of the dipole. Let OR make an angle θ with dipole axis. The potential at R due to the dipole (fig. 2.22) is

$$V_R = \frac{1}{4\pi \epsilon_0} \left[\frac{q}{BR} + \frac{-q}{AR} \right]$$

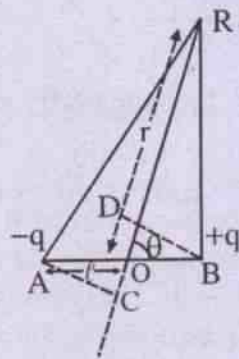

Fig. 2.22

Let BD and AC be perpendiculars drawn respectively from B and A on RO and extended RO. Then $OC = OD = l \cos \theta$ since $r \gg l$,

$BR = DR = (r - l \cos \theta)$ and $AR = CR = (r + l \cos \theta)$

$$\begin{aligned} \text{Hence } V_R &= \frac{1}{4\pi \epsilon_0} \left[\frac{q}{r - l \cos \theta} - \frac{q}{r + l \cos \theta} \right] \\ &= \frac{1}{4\pi \epsilon_0} \cdot \frac{2ql \cos \theta}{r^2 - l^2 \cos^2 \theta} \\ &= \frac{1}{4\pi \epsilon_0} \cdot \frac{P \cos \theta}{r^2 - l^2 \cos^2 \theta} \dots (2.28.3) \end{aligned}$$

$\therefore l \ll r, l^2 \cos^2 \theta$ can be neglected in comparison with r^2 .

$$\therefore V_R = \frac{1}{4\pi \epsilon_0} \cdot \frac{P \cos \theta}{r^2} \dots (2.28.4)$$

a) Potential at a point on the dipole axis is obtained by putting $\theta = 0$ in eqn. (2.28.3)

$$V_R = \frac{1}{4\pi \epsilon_0} \cdot \frac{P}{r^2 - l^2}$$

which is same as eqn. (2.28.1)

b) Potential due to dipole at a point on the dipole equator is obtained by putting $\theta = 90^\circ$ in eqn. (2.28.3)

$$\therefore V = 0$$

2.29 Conductor, Insulator and Dielectrics :

Any piece of matter of moderate size contains a large numbers of atoms or molecules. Each atom consists of a positively charged nucleus and several electrons revolve around it. In gases, the atoms or molecules almost do not interact with each other. But in case solids and liquids, the interaction is comparatively stronger. It turns out that the materials may be broadly divided into conductor, insulator and semiconductor. However we shall briefly discuss about conductors and insulators and leave the discussion on semiconductors to

chapter-19.

2.29.1 Conductors :

In case of conductors the outer electrons of each atom or molecule are very weakly bound to it. These electrons are almost free (so called free electrons) to move throughout the material, but cannot leave the material. These free electrons are also called conduction electrons but they carry the charge. When such a material is placed in an electric field, the free electrons move in a direction opposite to the field. *In case of electrolytic conductors, the charge carries are both positive and negative ions. But their motion is affected by external field as well as by chemical forces.*

The following characteristics are associated with a metallic conductor.

1. The net electrostatic field inside a conductor is zero.

The free electrons move randomly inside a conductor, so the net electrostatic field is zero inside a conductor.

2. The electrostatic field must be normal to the surface of a conductor.

If electrostatic field were not normal to the surface, it would have some non-zero components along the surface. This will force electrons to move on the surface and this will constitute a current. But this does not happen.

3. Electrostatic potential is constant throughout the volume of the conductor and has same value on its surface.

4. Electrostatic field on the surface of a

charged conductor is $\vec{E} = \frac{\sigma}{\epsilon_0} \hat{n}$

5. If a conductor is connected to the earth, the potential of the conductor becomes equal to that of earth i.e., zero; charges will either move to the earth or from earth to the conductor.

2.29.2 Insulators :

Materials in which there are no free electrons are called insulators. When such a material is placed in an electric field, the electrons may slightly shift opposite to the field but cannot leave their parent atoms or molecules. Such materials are also called dielectrics.

2.29.3 Dielectrics:

There are no free electrons in a dielectric material. The monatomic materials are made of atoms. Each atom consists of a positively charged nucleus surrounded by revolving electrons. In general, the centre of the positive charges coincides with the centre of the negative charges. Polyatomic materials are made of molecules. the centre of negative charge distribution may or may not coincide with the centre of positive charge distribution. If these charge centres do not coincide, then each molecule possesses a permanent dipole moment \vec{p} . Such materials are called polar materials (Ex. HCl, H₂O see fig. 2.29.1).

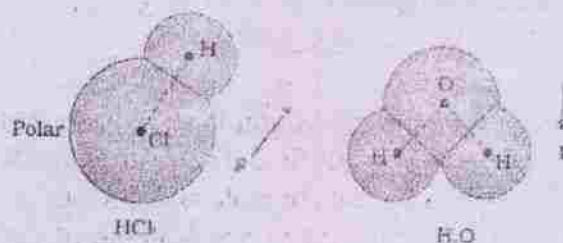

Fig.2.29.1

However due to thermal agitation the dipole moments of different molecules are randomly oriented leading to zero net dipole moment. If such a material is placed in an electric field the individual dipoles experience torque due to the field and try to align themselves along electric field direction. Due to the interplay of thermal agitation and torque due to electric field there is a partial alignment. As a result we obtain a net dipole moment in any volume of the material (see fig. 2.29.2(a)).

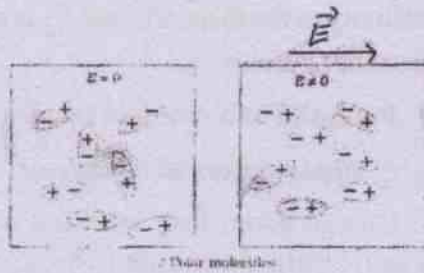

Fig. 2.29.2

In case of non-polar materials (Ex. H_2 , CO_2), the centre of positive charge distribution in an atom or a molecule coincides with the centre of negative charge distribution as shown in fig.2.29.3. Such atoms or molecules do not possess any permanent dipole moment. when such a material is placed in an electric field, the

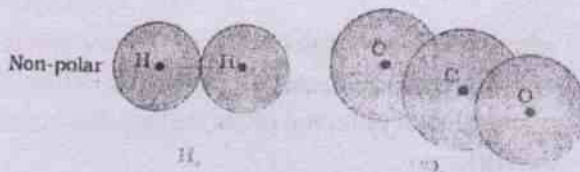

Fig. 2.29.3

electric charge distribution is slightly shifted opposite to the electric field. This induces dipole moment in each atom or molecule and thus we get a dipole moment in any volume of the material (see fig. 2.29.4).

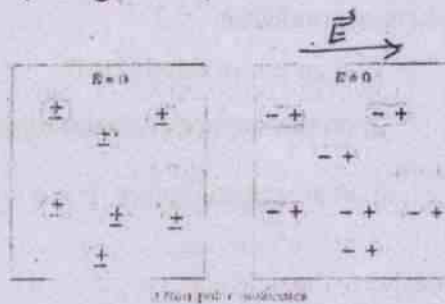

Fig.2.29.4

From the above discussion and figures we find that the interior is still charge free but the left surface of the slab gets negative charge and the

right surface gets positive charge. This situation may be seen in fig. 2.29.5 below. This charge is called induced charge. As the induced charge appears due to shift in the electrons bound to

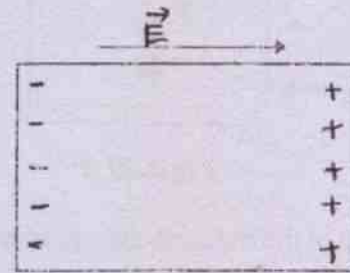

Fig.2.29.5

the nuclei, this charge is also call **bound charge**. Thus, the above discussion shows that whenever a dielectric is placed in an electric field, dipole moment appears in any volume within it. **This phenomenon of development of dipole moment in any volume of the material of a dielectric when the dielectric is placed in an external electric field is known as polarisation. The polarisation vector \vec{p} is defined as dipole moment per unit volume.** Now considering a rectangular slab as shown above we find

$$P = \frac{(\sigma pA)l}{Al} = \frac{\sigma p(Al)}{Al} = \sigma P \quad \text{---(2.29.1)}$$

$$\text{or } \sigma p = P \cdot \hat{n} \quad \text{---(2.29.2)}$$

Where \hat{n} is a unit vector along the outward drawn normal to the surface. For the slab \vec{p} is along \hat{n} at the right surface and opposite to \hat{n} at the left surface.

Although we have deduced this for a rectangular slab but this result is true in general. Thus the induced surface charge density σ_p is numerically equal to the polarisation P . For linear isotropic dielectrics

$$P = \vec{P} = \epsilon_0 \chi_e E = \epsilon_0 \chi_e E$$

Dielectric constant:

Fig.2.29.6

Because of the induced charge, an extra electric field \vec{E}_p is developed inside the dielectric material. If \vec{E}_0 be the external electric field, then the resultant electric field inside the dielectric is $\vec{E} = \vec{E}_0 + \vec{E}_p$. For homogeneous and isotropic dielectrics the field \vec{E}_p and \vec{E}_0 are oppositely directed but the resultant electric field \vec{E} is in the direction of \vec{E}_0 with a reduced magnitude.

We can put $\vec{E} = \vec{E}_0 + \vec{E}_p$ -----.....(2.29.3)

But $E_p = \frac{\sigma P}{\epsilon_0} = \frac{P}{\epsilon_0}$; But as \vec{E}_p is opposite to

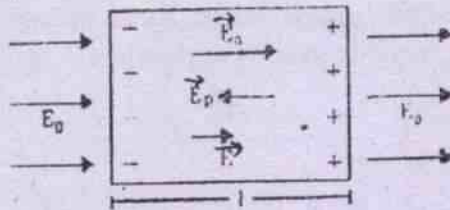
$$\vec{P} \text{ so } \vec{E}_p = -\frac{\vec{P}}{\epsilon_0}$$

$$\text{Givign } \vec{E} = \vec{E}_0 - \frac{\vec{P}}{\epsilon_0} \Rightarrow \epsilon_0 \vec{E} + \vec{P} = \epsilon_0 \vec{E}_0 \quad (2.29.4)$$

$$\text{Defining } \vec{D} = \epsilon_0 \vec{E} + \vec{P} = \epsilon_0 \vec{E}_0$$

$$\text{We get } \oint (\epsilon_0 \vec{E} + \vec{P}) \cdot d\vec{s} = \oint \epsilon_0 \vec{E}_0 \cdot d\vec{s}$$

From Gauss theorem $Q_{free} = \oint \epsilon_0 \vec{E}_0 \cdot d\vec{s}$. Hence

$$\oint \vec{D} \cdot d\vec{s} = Q_{free}$$

$$\text{And } \vec{D} = \epsilon_0 \vec{E} + \vec{P} = \epsilon_0 \vec{E} + \epsilon_0 X_c \vec{E}$$

$$= \epsilon_0 (1 + X_c) \vec{E} = \epsilon \vec{E} \quad \text{-----}(2.29.6)$$

Where ϵ is called dielectric constant or relative permittivity of the dielectric and \vec{D} is called the displacement vector.

2.30 Potential of a charged conductor**i) Charged spherical conductor**

Charge given to a spherical conductor gets uniformly distributed throughout the surface of the conductor. As there is no charge within the conductor, according to Gauss law, the electric field within the conductor is zero. Since

$E = -\frac{dV}{dr} = 0$, $\Delta V = 0$. Hence entire volume of the conductor behaves as an equipotential volume having the potential

$$V = \frac{q}{4\pi \epsilon_0 R} \quad \text{....(2.29.1)}$$

where q is the charge on the conductor and it is considered to be concentrated at its centre for calculation of potential on its surface and outside the surface.

Potential at any point outside the charged spherical conductor at a distance $r > R$ from its centre is

$$V = \frac{q}{4\pi \epsilon_0 r} \quad \text{....(2.29.2)}$$

Electric field intensity due to a charged spherical conductor

1. at an internal point is 0
2. on the surface of the conductor
3. at an external point $E = q / 4\pi \epsilon_0 R^2$

$$E = \frac{q}{4\pi \epsilon_0 r^2}$$

where $r > R$

ii) Charged irregular conductor

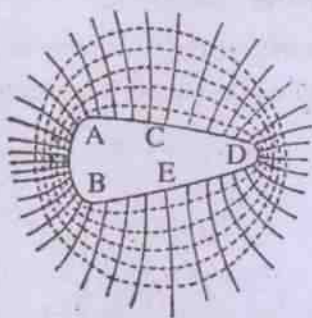

Equipotential surfaces (dotted lines) and lines of force (solid lines) of a charged conductor of irregular shape.

Fig. 2.23

Fig. (2.23) is an irregular conductor with a positive charge. Dotted lines indicate equipotential lines and solid lines indicate lines of force. From the study of these lines and other established facts we can arrive at the following conclusions :

1. Charges stay only on its surface.
2. Charges are not uniformly distributed on its surface.
3. There is a greater surface density of charge in the region of larger curvature (at A, B and D) lower surface density of charges at smaller curvature (at C and E).
4. Electric field intensity inside the conductor is zero.
5. Electric potential throughout the volume of the conductor remains same creating an equipotential volume.

2.31 Electric potential energy of a group of point charges :

The electric potential energy of a group of point charges is defined as the work done in assembling the group from the situation when they were at infinite distances from each other (i.e. their initial electrical potential energy is zero as there is no interaction between them)

i) Electric potential energy of a system consisting of two point charges :

Consider a point charge q_1 situated at A and another point charge q_2 brought from infinity to the point B in the electric field of q_1 . The work done (by an external agent) in doing so is equal to the potential energy of the two point charges.

Let P be the instantaneous position of q_2 at a distance x from the point A (fig. 2.24).

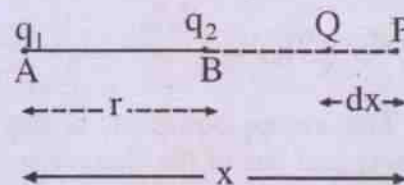

Fig. 2.24

Coulomb force on q_2 due to q_1 is

$$F = \frac{1}{4\pi\epsilon_0} \cdot \frac{q_1 q_2}{x^2}$$

Work done for an instantaneous displacement dx of the charge q_2 from the point P to Q is

$$\begin{aligned} dW &= \vec{F} \cdot d\vec{x} \\ &= F dx \cos 0^\circ \\ &= F dx \\ &= -\frac{1}{4\pi\epsilon_0} \cdot \frac{q_1 q_2 dx}{x^2} \end{aligned}$$

The negative sign in the above eqn. is due to the fact that external force applied by the agent is equal and opposite to the electrical force.

Total work done in displacing the charge from infinity to the point B which is at a distance r from A is obtained by integrating the above expression.

$$\int_0^w dw = \int_\infty^r -\frac{1}{4\pi\epsilon_0} \cdot \frac{q_1 q_2 dx}{x^2}$$

$$\begin{aligned}
 \text{or } W &= -\frac{q_1 q_2}{4\pi \epsilon_0} \int_{\infty}^r \frac{dx}{x^2} \\
 &= -\frac{q_1 q_2}{4\pi \epsilon_0} \left[-\frac{1}{x} \right]_{\infty}^r \\
 &= \frac{q_1 q_2}{4\pi \epsilon_0} \left[\frac{1}{r} - \frac{1}{\infty} \right] \\
 W &= \frac{1}{4\pi \epsilon_0} \cdot \frac{q_1 q_2}{r} \quad \dots(2.30.1)
 \end{aligned}$$

The above equation is derived by assuming that one of the charges is fixed and the other is brought from infinity. Without changing its kinetic energy. According to work-energy principle, work done by the agent is equal to change in the potential energy of the system, i.e.

$$\begin{aligned}
 W &= U(r) - U(\infty) \\
 &= U(r)
 \end{aligned}$$

Where $U(r)$ is the potential energy of the two charges q_1 and q_2 when they are separated by a distance r . $U(\infty)$ is their potential energy when they are at infinite separation and it is equal to zero.

$$\therefore W = U(r) = \frac{1}{4\pi \epsilon_0} \cdot \frac{q_1 q_2}{r} \quad \dots(2.30.2)$$

The potential energy depends only upon the separation between the charges and is independent of the spatial location of the charges.

Eqn. (2.30.2) gives the electric potential energy of a pair of charges. If there are three charges q_1 , q_2 , and q_3 , one has to take into account of three different pairs of charges as given below:

ii) **Potential energy of a system consisting of three charges :**

Let the system consisting of three charges q_1 , q_2 and q_3 be situated as shown in the fig. 2.25.

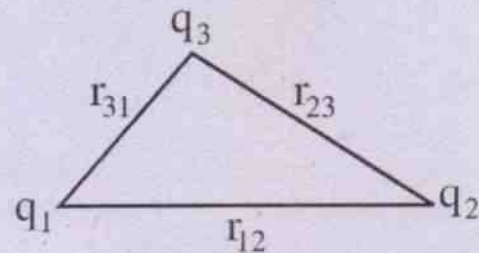

Fig. 2.25

Potential energy of a pair of charges q_1 and q_2 is

$$U_{12} = \frac{q_1 q_2}{4\pi \epsilon_0 r_{12}}$$

Similarly due to other two pairs of charges, the potential energies are

$$U_{23} = \frac{q_2 q_3}{4\pi \epsilon_0 r_{23}}$$

$$\text{and } U_{31} = \frac{q_3 q_1}{4\pi \epsilon_0 r_{31}}$$

Total potential energy of the system consisting of three charges is

$$\begin{aligned}
 U &= U_{12} + U_{23} + U_{31} \\
 &= \frac{1}{4\pi \epsilon_0} \left[\frac{q_1 q_2}{r_{12}} + \frac{q_2 q_3}{r_{23}} + \frac{q_3 q_1}{r_{31}} \right] \quad \dots(2.30.3)
 \end{aligned}$$

iii) **If the system consists of n number of point charges, one has to consider $\frac{n(n-1)}{2}$ different pairs of charges to give $\frac{n(n-1)}{2}$ potential energy terms like eqn. (2.30.2).**

2.32 Relation between electric field intensity and potential gradient :

Electric potential gradient $\frac{dV}{dr}$ is the rate of change of potential with distance along a line of force. Its SI unit is volt per meter. There is a direct relationship between electric field intensity and potential gradient.

Consider two points a and b which are separated by an infinitesimal distance dr on a

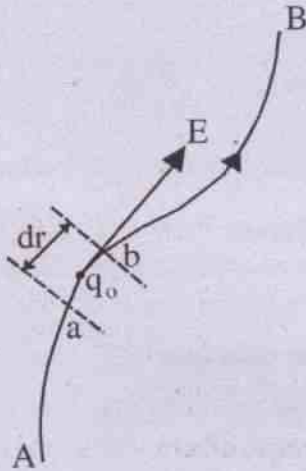

Fig. 2. 26

line of force AB in an electric field (fig. 2.26). The field is considered to be uniform over the small distance dr . If a test charge $+q_0$ is moved from a to b, work is done by the field on the charge.

Work done by the field is given by

$$dW = \vec{F} \cdot d\vec{r}$$

$$= q_0 \vec{E} \cdot d\vec{r}$$

The change in potential is the negative of the work done by the field per unit charge during the displacement.

In terms of change in potential is

$$dV = \frac{-dW}{q_0} = -\vec{E} \cdot d\vec{r} \quad \dots(2.31.1)$$

$$\text{or } dV = -E dr \cos \theta \quad \dots(2.31.2)$$

where θ is the angle between the direction of electric field and dr .

$$-\frac{dV}{dr} = E \cos \theta \quad \dots(2.31.3)$$

If the test charge $+q_0$ is moved along the line of force i.e. in the direction of electric field, $\theta = 0^\circ$ and electric field intensity

$$E = -\frac{dV}{dr} \quad \dots(2.31.4)$$

Eqn. (2.31.4) states an important relationship. *The electric field intensity at a point in an electric field is equal to the negative of the potential gradient of the field at that point.* Further the electric field is in the direction in which potential decreases at the maximum rate.

Rate of change of potential in any direction other than that of electric field is

$$\frac{dV}{dr} = -E \cos \theta$$

$$\text{or } E \cos \theta = -\frac{dV}{dr}$$

Hence the component of electric field intensity in any given direction is equal to the negative of the rate of change of potential in that direction.

$$\text{If } \theta = 90^\circ, dV = 0$$

Hence potential does not vary in a direction perpendicular to the electric field and vice versa i.e. electric lines of force and equipotential lines intersect at right angles to each other.

Let us write eqn. (2.31.1) in cartesian component form :

$$dV = -(\hat{i}E_x + \hat{j}E_y + \hat{k}E_z) \cdot (\hat{i}dx + \hat{j}dy + \hat{k}dz)$$

$$= -(E_x dx + E_y dy + E_z dz) \quad \dots(2.31.5)$$

Taking partial derivative of both sides of the above eqn. (2.31.5) with respect to x , we have

$$\frac{\partial V}{\partial x} = -E_x$$

$$\text{or } E_x = -\frac{\partial V}{\partial x}$$

$$\text{similarly } E_y = -\frac{\partial V}{\partial y} \quad \dots(2.31.6)$$

$$\text{and } E_z = -\frac{\partial V}{\partial z}$$

$$\therefore \vec{E} = -\left(\hat{i} \frac{\partial V}{\partial x} + \hat{j} \frac{\partial V}{\partial y} + \hat{k} \frac{\partial V}{\partial z}\right) \quad \dots(2.31.7)$$

If $V = f(x, y, z)$, eqn. (2.31.7) can be used to calculate electric field intensity at a point.

Example 2.31.1 Two large metal plates are kept parallel to each other at a separation of 6 mm. The potential of one is maintained at 90 V above the other. What is the potential gradient between the plates. What is the force experienced by an α -particle kept between the plates.

Solution :

$$\Delta V = 90 \text{ V}, \Delta r = 6 \times 10^{-3} \text{ m}$$

$$\text{Potential gradient } \frac{dv}{dr} = \frac{90}{6 \times 10^{-3}} = 15 \times 10^3 \text{ V/m}$$

Electric field between the plates is uniform and

$$E = -\frac{dv}{dr}$$

Hence magnitude of electric field intensity is $15 \times 10^3 \text{ V/m}$ and its direction is towards the plate at lower potential.

Force on α -particle is

$$\begin{aligned} F &= Eq \\ &= 15 \times 10^3 \times 2 \times 1.6 \times 10^{-19} \\ &= 48 \times 10^{-16} \text{ N} \end{aligned}$$

Direction of the force is towards the plate at lower potential

Example 2.31.2 A region is specified by the potential function $V = (x^2 + 2y^2 - 3z^2)$ volt. Calculate electric field strength at a point (3, 2, 1) m in this region.

Solution :

$$\begin{aligned} \vec{E} &= -\left(\hat{i} \frac{\partial}{\partial x} + \hat{j} \frac{\partial}{\partial y} + \hat{k} \frac{\partial}{\partial z}\right)(x^2 + 2y^2 - 3z^2) \\ &= -(2x \hat{i} + 4y \hat{j} - 6z \hat{k}) \end{aligned}$$

At $x = 3, y = 2, z = 1,$

$$\vec{E} = -(6 \hat{i} + 8 \hat{j} - 6 \hat{k}) \text{ volt/m}$$

2.33 Equipotential lines and surfaces :

Equipotential lines and surfaces drawn graphically in an electric field, show how the potential varies in a region.

a) Equipotential lines :

An equipotential line is a line (curve) in an electric field so drawn that all the points on the line (curve) are at the same potential.

Characteristics of equipotential lines

- i) The potential difference between any two points of an equipotential line is zero. Hence no electrical work is done if a charge is displaced from one point to another on the same equipotential line.
- ii) Equipotential lines and the lines of force always intersect at right angles to each other. Thus, if the lines of force are drawn, equipotential lines can immediately be constructed and vice versa.
- iii) Two different equipotential lines cannot intersect. If they intersect, at the point of intersection, there will be two values of potential which is not possible.

b) **Equipotential surfaces :**

An equipotential surface is a surface that is drawn through the points which are at the same potential. Surface of a charged conductor with charges at rest is an equipotential surface. If there were a potential difference between points on the surface, charges would move along the surface which is contrary to our assumption of electrostatic condition.

The shape of an equipotential surface due to a charge depends on its distribution and the medium in which equipotential surfaces are drawn. A regular equipotential surface due to a charge distribution in an isotropic medium becomes irregular in an anisotropic medium as the potential due to a charge is inversely proportional to dielectric constant of the medium.

The equipotential surfaces around a point charge in an isotropic medium, are a series of concentric spheres with the charge at the centre.

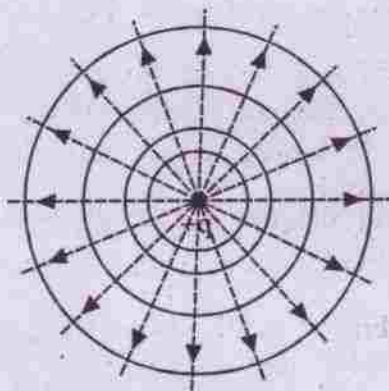

Fig. 2.27

Fig (2.27) shows equipotential surfaces (solid lines) and electric lines of force (broken lines) due to a point positive charge $+q$. It is a convention to draw equipotential surfaces in such a way that the difference of potential between any two adjacent surfaces is same.

When two electric fields are superposed due to two charge distributions, the resulting

equipotential surfaces are drawn by determining the potential at various points using the principle of superposition of potentials. Fig (2.28) shows equipotential lines (solid lines) and lines of force (broken lines) on a plane surface due to two charges of equal magnitude and opposite sign whereas fig (2.29) for two equal positive charges.

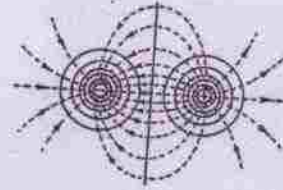

Fig. 2.28

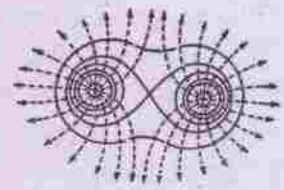

Fig. 2.29

Characteristics of equipotential surfaces :

- i) No electrical work is done in displacing a charge from one point to another on the same equipotential surface. However, a work is done in displacing a charge from one equipotential surface to another but the work is independent of path in which the charge is moved.
- ii) Equipotential surfaces and lines of force intersect at right angles to each other.
- iii) Two different equipotential surfaces cannot intersect.
- iv) Equipotential surfaces are crowded in the region of strong field and widely separated in the region of weak field.

SUMMARY

- 1) **Electric field :** It is a region of three dimensional space surrounding a charge in which its electrical influence can be felt.
- 2) **Electric field intensity (\vec{E}) :** Electric field intensity at any point in an electric field is given (both in magnitude and direction) by the force experienced by a unit

positive charge placed at that point.

- 3) **Electric field intensity at any point due to a point charge :**

$$\vec{E}(\vec{r}) = \frac{1}{4\pi\epsilon_0} \frac{q}{r^2} \hat{r}$$

- 4) **Electric line of force :** It is a continuous curve in an electric field, the tangent to it at any point gives the direction of electric field at that point. Number of electric lines of force per unit normal area at a point gives the electric field intensity at that point.

5. **Electric dipole :** Two equal and opposite charges separated by a small distance constitute an electric dipole.

6. **Dipole moment (\vec{P}) :** It is the product of magnitude of one of its charges and distance between them. Its direction is from its negative charge to positive charge and its unit is Cm.

$$\vec{P} = 2q\vec{\ell}$$

7. **Electric field due to a dipole :**

i) At end on position is

$$\vec{E}_p = \frac{1}{4\pi\epsilon_0} \frac{2r\vec{P}}{(r^2 - \ell^2)^2}$$

For a far field

$$\vec{E}_p = \frac{1}{4\pi\epsilon_0} \frac{2\vec{P}}{r^3}$$

ii) At broad-side on position is

$$\vec{E}_Q = \frac{1}{4\pi\epsilon_0} \frac{(-\vec{P})}{(r^2 + \ell^2)^{3/2}}$$

For a far field

$$\vec{E}_Q = \frac{1}{4\pi\epsilon_0} \frac{(-\vec{P})}{r^3}$$

8. Torque experienced by an electric dipole in a uniform electric field is

$$T = PE \sin \theta$$

$$\vec{T} = \vec{P} \times \vec{E}$$

9. Work done in rotating an electric dipole in a uniform electric field through an angle θ from equilibrium position is $w = PE(1 - \cos \theta)$

10. Electric potential energy of a dipole in an electric field is $U = -\vec{P} \cdot \vec{E}$.

11. **Gauss theorem :** It states that the electric flux through any closed surface is equal to the net charge q enclosed by the surface divided by ϵ_0 .

$$\text{Mathematically } \oint \vec{E} \cdot d\vec{s} = \frac{q}{\epsilon_0}$$

12. Electric field at a point at a distance r from a linear distribution of charge of linear charge density λ is

$$E = \frac{\lambda}{2\pi\epsilon_0 r}$$

13. Electric field due to an infinite plane sheet of charge

$$E = \frac{\sigma}{2\epsilon_0}$$

where σ is the surface charge density.

14. Electric field due to a uniformly charged plane lamina is

$$E = \frac{\sigma}{\epsilon_0}$$

15. Electric field inside a parallel plate capacitor is

$$E = \frac{\sigma}{\epsilon_0}$$

POTENTIAL

16. Electric field is conservative in nature because work done in taking a charge from one point to another in an electric field is independent of its path.
17. Electrostatic potential energy of a charge at a point in an electric field is defined as the work done in displacing the charge from infinity to that point.

$$\text{Mathematically } U(r) = -q \int_{\infty}^r \vec{E} \cdot d\vec{r}$$

18. Potential at a point is defined as the work done in bringing a unit charge from infinity to that point.

$$V(r) = - \int_{\infty}^r \vec{E} \cdot d\vec{r}$$

19. Potential difference between two points in an electric field is the work done per unit charge to take it from one point to the other.

$$\Delta V = V_B - V_A = - \int_A^B \vec{E} \cdot d\vec{r}$$

20. 1 stat volt = 300 volt = 3.0×10^{11} ab-volt

21. Potential due to a point charge

i) $V = \frac{1}{4\pi\epsilon_0} \cdot \frac{q}{r}$ in S.I. system

ii) $V = \frac{q}{r}$ in cgs (esu) system

22. Potential at a point due to a system of n

point charges is,

$$V = \frac{1}{4\pi\epsilon_0} \sum_{i=1}^n \frac{q_i}{r_i}$$

23. Potential due to an electric dipole

- i) at a point P on its axis is

$$V_P = \frac{1}{4\pi\epsilon_0} \cdot \frac{P}{(r^2 - \ell^2)}$$

- ii) at a point Q in the equatorial line

$$V_Q = 0$$

- iii) at a general point R is

$$V_R = \frac{1}{4\pi\epsilon_0} \cdot \frac{P \cos \theta}{r^2}$$

26. Potential energy due to

- i) two charges q_1 and q_2 at a distance of separation r is

$$U(r) = \frac{1}{4\pi\epsilon_0} \cdot \frac{q_1 q_2}{r}$$

- ii) a group of charges is

$$U = \frac{1}{4\pi\epsilon_0} \left[\frac{q_1 q_2}{r_{12}} + \frac{q_2 q_3}{r_{23}} + \dots \right]$$

27. Electric field intensity and potential gradient are related by

$$E = - \frac{dV}{dr}$$

28. Potential at every point on an equipotential line and equipotential surface is same.

29. No two equipotential lines intersect.

30. Equipotential lines and electric lines of force intersect at right angles to each other.

SOLVED NUMERICAL EXAMPLES

1. The electric force experienced by a charge of 1.0×10^{-6} C is 1.5×10^{-5} N. Find the magnitude of electric field intensity at the position of charge.

Solution :

Given $q = 1.0 \times 10^{-6}$ C, $F = 1.5 \times 10^{-5}$ N

$$\text{Electric field intensity } E = \frac{F}{q} = \frac{1.5 \times 10^{-5}}{1.0 \times 10^{-6}} \\ = 15 \text{ N/C}$$

2. Two charges $+2\mu\text{C}$ and $-4\mu\text{C}$ are held fixed at a separation of 20 cm. Locate the point where the electric field intensity due to these two charges is zero.

Solution :

Electric field at a point due to two charges can be zero only on the line joining the two charges. If the two charges are opposite in nature, the electric field can never be zero within two charges. The required point must be outside the line joining the two charges nearer to smaller charge.

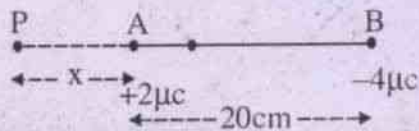

Fig. 2.14

Let P be a point at a distance x from a smaller charge $2\mu\text{C}$ at A as shown in the fig. 2.14.

$$\vec{E}_A + \vec{E}_B = 0$$

$$\frac{q_A}{4\pi\epsilon_0 x^2} + \frac{q_B}{4\pi\epsilon_0 (0.2+x)^2} = 0$$

$$\text{or } \frac{2 \times 10^{-6}}{x^2} + \frac{-4 \times 10^{-6}}{(0.2+x)^2} = 0$$

$$\text{or } (0.2+x)^2 = 2x^2$$

$$0.2+x = \sqrt{2}x$$

$$x(\sqrt{2}-1) = 0.2$$

$$x = 0.483 \text{ m}$$

Field intensity is zero at a distance 48.3 cm from A on the line BA extended.

3. The metallic bob of a simple pendulum (hanged from a rigid support) has a mass 80 mg and carries a charge 2×10^{-8} C. It is at rest in a uniform horizontal electric field of 2×10^4 N/C. Find the tension in the string ($g = 10 \text{ ms}^{-2}$)

Solution :

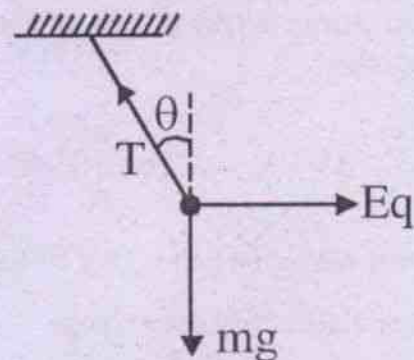

Fig. 2.15

Given : mass $m = 80 \times 10^{-6}$ kg

$q = 2 \times 10^{-8}$ C, $E = 2 \times 10^4$ N/C

Tension $T = ?$

For equilibrium of the bob,

$$T \cos \theta = mg$$

$$T \sin \theta = Eq$$

$$\therefore T = \sqrt{(mg)^2 + (Eq)^2}$$

$$= \sqrt{(80 \times 10^{-6} \times 10)^2 + (2 \times 10^4 \times 2 \times 10^{-8})^2}$$

$$= 10^{-4} \sqrt{64 + 16}$$

$$= 4\sqrt{5} \times 10^{-4} \text{ N} = 40\sqrt{5} \text{ dyne.}$$

4. A charge of $5.31 \times 10^{-7} \text{ C}$ is placed at the centre of an imaginary cube. Find the electric flux passing through one of its faces.

Solution :

Given : $q = 5.31 \times 10^{-7} \text{ C}$.

$$\epsilon_0 = 8.85 \times 10^{-12} \text{ C}^2 \text{ m}^{-2} \text{ N}^{-1}$$

According to Gauss's law, electric flux

through any closed surface $\phi = \frac{q}{\epsilon_0}$. Since

the cube has 6 faces of equal area, flux through one of its faces is

$$\phi = \frac{q}{6 \epsilon_0}$$

$$= \frac{5.31 \times 10^{-8}}{6 \times 8.85 \times 10^{-12}}$$

$$= 10^4 \text{ Nm}^2 \text{ C}^{-1}$$

5. Two point charges $1.0 \times 10^{-12} \text{ C}$ and $-1.0 \times 10^{-12} \text{ C}$ are placed along the x-axis at $x = 3 \text{ cm}$ and $x = -3 \text{ cm}$ respectively. Find electric field intensity at a point $(0, 4 \text{ cm})$.

Solution :

Electric field intensity at a point on broadside on position of the dipole is

$$E_Q = \frac{P}{4\pi \epsilon_0 (r^2 + \ell^2)^{3/2}}$$

$$= \frac{2q\ell}{4\pi \epsilon_0 (r^2 + \ell^2)^{3/2}}$$

$$= \frac{9 \times 10^9 \times 2 \times 10^{-12} \times 3 \times 10^{-2}}{(0.04^2 + 0.03^2)^{3/2}}$$

$$= \frac{9 \times 6 \times 10^{-5}}{125 \times 10^{-6}}$$

$$= 4.32 \text{ N/C}$$

6. A rod of length ℓ has a charge q distributed uniformly along its length. It is bent in the shape of a semicircle. Find the field strength at the centre of curvature of the semicircle.

Solution :

Consider two elements each of length $d\ell$ such that they are symmetrically situated on either side of the mid point C of the semicircle. Charge per unit length is $\frac{q}{\ell}$.

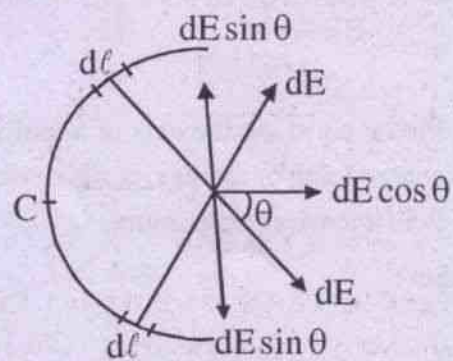

Fig. 2.16

Charge on the element $d\ell$ is $\frac{q}{\ell} d\ell$

Radius of the semicircle, $r = \frac{\ell}{\pi}$

Electric field due to charge on one element $d\ell$ is

$$dE = \frac{1}{4\pi\epsilon_0} \cdot \frac{q d\ell}{r^2}$$

Let us resolve dE into two component $dE \cos \theta$ and $dE \sin \theta$. $dE \sin \theta$ components due to two elements $d\ell$ and $d\ell$ on either side of the point C cancel each other while only $dE \cos \theta$ component remains. We can argue for all such elements throughout the semicircle.

Hence electric field strength due to entire charge on the semicircle is

$$\begin{aligned} E &= \int dE \cos \theta \\ &= \frac{1}{4\pi\epsilon_0} \cdot \frac{q}{\ell} \int_{-\pi/2}^{\pi/2} \frac{rd\theta \cos \theta}{r^2} \\ &\quad (\because d\ell = rd\theta) \\ &= \frac{1}{4\pi\epsilon_0} \cdot \frac{q}{\ell r} [\sin \theta]_{-\pi/2}^{\pi/2} \\ &= \frac{1}{4\pi\epsilon_0} \cdot \frac{2q}{\ell \times \frac{\ell}{\pi}} \\ E &= \frac{q}{2\epsilon_0 \ell^2} \end{aligned}$$

7. Find a point, on the axis of a uniformly charged ring of radius r , at which electric field intensity is maximum.

Solution :

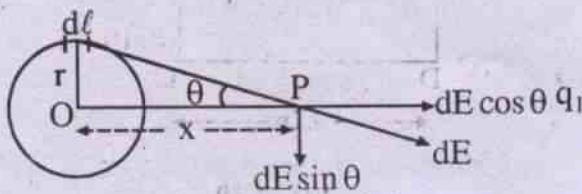

Proceeding as in above example 6, we can show that only $\cos \theta$ component of electric field exists. Electric field due to small element $d\ell$ is

$$\begin{aligned} dE &= dE \cos \theta \\ &= \frac{q}{4\pi\epsilon_0} \cdot \frac{\lambda d\ell}{(x^2 + r^2)} \cdot \cos \theta \end{aligned}$$

where λ is the charge per unit length. x is the distance of the point P from the centre of the ring. Electric field at the point P due to entire charge on the ring is

$$\begin{aligned} E &= \frac{1}{4\pi\epsilon_0} \cdot \frac{\lambda \cos \theta}{(x^2 + r^2)} \int_0^{2\pi r} d\ell \\ E &= \frac{1}{4\pi\epsilon_0} \cdot \frac{\lambda 2\pi r}{(x^2 + r^2)} \cdot \frac{x}{(x^2 + r^2)^{1/2}} \end{aligned}$$

we note here that, at the centre of the uniformly charged ring, the electric field is zero ($\because x = 0$)

Condition for maximum electric field at a point on the axis is, $\frac{dE}{dx} = 0$

$$\text{i.e. } \frac{\lambda 2\pi r}{4\pi\epsilon_0} \left[\frac{1}{(x^2 + r^2)^{3/2}} - \frac{3}{2} \frac{x \times 2x}{(x^2 + r^2)^{5/2}} \right] = 0$$

$$\text{or } \frac{1}{(x^2 + r^2)^{3/2}} = \frac{3x^2}{(x^2 + r^2)^{5/2}}$$

$$\text{or } x^2 + r^2 = 3x^2$$

$$\text{or } x^2 = r^2 / 2$$

$$\text{or } x = r/\sqrt{2}$$

8. A hollow spherical conductor of radius 1.0 m has a charge of $0.025 \mu\text{C}$. Find electric potential at a point at a distance 0.5 m from its centre.

Solution :

Potential at any point inside the charged spherical conductor is same and equal to that on its surface.

$$\begin{aligned} \therefore V &= \frac{q}{4\pi \epsilon_0 R} \quad \text{where } R = 1.0\text{m, } q = 2.5 \times 10^{-8}\text{C} \\ &= \frac{9 \times 10^9 \times 2.5 \times 10^{-8}}{1} \\ &= 225 \text{ V} \end{aligned}$$

9. A hollow metal sphere has a radius r . If the potential difference between its surface and a point at a distance $3r$ from its centre is V , find electric field intensity at a distance $3r$ from its centre.

Solution :

Let q be the charge on the metal sphere.

$$\therefore \frac{q}{4\pi \epsilon_0} \left[\frac{1}{r} - \frac{1}{3r} \right] = V$$

$$\text{or } q = \frac{V \times 4\pi \epsilon_0 \times 3r}{2}$$

$$\therefore E = \frac{q}{4\pi \epsilon_0 (3r)^2} = \frac{3Vr}{2} \times \frac{1}{9r^2} = \frac{V}{3r}$$

10. An electron starts from rest from a point on one conductor and reaches a second conductor with a velocity of 10^7 ms^{-1} . Calculate the potential difference between the conductors. [neglect the relativistic effect of mass of the electron. $m_e = 9.1 \times 10^{-31} \text{ kg}$, $e = 1.6 \times 10^{-19} \text{ coul}$]

Solution :

Kinetic energy acquired by an electron in a potential difference of V volt is

$$\frac{1}{2} m \theta^2 = eV$$

$$\text{or } V = \frac{m \theta^2}{2e}$$

$$\begin{aligned} &= \frac{9.1 \times 10^{-31} \times 10^{14}}{2 \times 1.6 \times 10^{-19}} \\ &= 284.4 \text{ volt} \end{aligned}$$

11. An electron is projected with a velocity of 10^7 ms^{-1} along a uniform electric field of intensity 900 Nc^{-1} . Find what distance it will travel before coming to momentary rest?

Solution :

$$\text{Work done} = F.S. = eE.S = \frac{1}{2} m \theta^2$$

$$S = \frac{m \theta^2}{2eE}$$

$$\begin{aligned} &= \frac{9.1 \times 10^{-31} \times 10^{14}}{2 \times 1.6 \times 10^{-19} \times 910} \\ &= 0.3125 \text{ m.} \end{aligned}$$

12. ABCD is a square measuring 0.2m on each side. Positive charges of $2 \times 10^{-9} \text{ C}$, $4 \times 10^{-9} \text{ C}$ and $8 \times 10^{-9} \text{ C}$ are placed at the points A, B and C respectively. Calculate work done to transfer one coulomb of charge from the point D to the centre of the square.

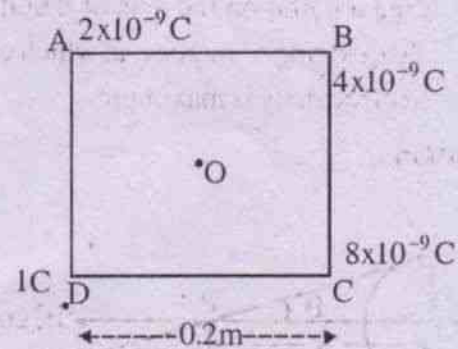

Fig. 2.30

Solution :

According to the principle of superposition of potentials, the potential at D is

$$V_D = \frac{1}{4\pi\epsilon_0} \left[\frac{q_A}{r} + \frac{q_B}{\sqrt{2}r} + \frac{q_C}{r} \right]$$

$$= 9 \times 10^9 \left[\frac{2 \times 10^{-9}}{0.2} + \frac{4 \times 10^{-9}}{0.2\sqrt{2}} + \frac{8 \times 10^{-9}}{0.2} \right]$$

$$= 9 [10 + 10\sqrt{2} + 40]$$

$$= 577.26 \text{ V}$$

Potential at the centre 'O' of the square

$$V_0 = \frac{1}{4\pi\epsilon_0} \left[\frac{2 \times 10^{-9}}{0.1 \times \sqrt{2}} + \frac{4 \times 10^{-9}}{0.1 \times \sqrt{2}} + \frac{8 \times 10^{-9}}{0.1 \times \sqrt{2}} \right]$$

$$= 9 [10\sqrt{2} + 20\sqrt{2} + 40\sqrt{2}]$$

$$= 9 \times 70\sqrt{2} = 890.82 \text{ V}$$

Potential difference $\Delta V = V_0 - V_D$

$$= 313.56 \text{ V}$$

$$\therefore \text{Work done} = \Delta V \cdot q$$

$$= 313.56 \times 1 = 313.56 \text{ J}$$

13. An electric field $\vec{E} = (2\hat{i} + 3\hat{j})\text{NC}^{-1}$ exists in free space. Find the potential difference between the origin and the point P (2m, 2m).

Solution :

Electric field $\vec{E} = (2\hat{i} + 3\hat{j})\text{NC}^{-1}$

Displacement $\Delta\vec{r} = (2\hat{i} + 2\hat{j})\text{m}$

Potential difference

$$\Delta V = -\vec{E} \cdot \Delta\vec{r}$$

$$= -(2\hat{i} + 3\hat{j}) \cdot (2\hat{i} + 2\hat{j})$$

$$= -(4 + 6)$$

$$V_P - V_0 = -10 \text{ V}$$

or $V_0 - V_P = 10 \text{ V}$

MODEL QUESTIONS

A. Multiple Choice Type Questions :

1. To measure electric field at a point due to a positive charge, a positive test charge q_0 is put at the point. The measured electric field is
 - a) $> \frac{F}{q_0}$
 - b) $= \frac{F}{q_0}$
 - c) $< \frac{F}{q_0}$
 - d) $> \text{ or } < \frac{F}{q_0}$

2. An electric field can deflect
 - a) an electron
 - b) a proton
 - c) an α -particle
 - d) all the above

3. The electric field intensity at the surface of a charged conductor is
 - a) zero
 - b) directed normally to the surface
 - c) directed tangentially to the surface
 - d) directed at an angle to the surface

4. If the electric field is uniform, then electric lines of force are
 - a) divergent
 - b) convergent
 - c) circular
 - d) parallel

5. The electric lines of force due to an isolated negative charge is
 - a) divergent
 - b) convergent
 - c) circular
 - d) parallel

6. An electric line of force in x-y plane is given by eqn. $x^2 + y^2 = 4$. A positively charged particle is set free at $x = 2, y = 0$ in the x-y plane. The particle will
 - a) not move at all
 - b) move initially in a straight line
 - c) move in a circular path
 - d) move first in a straight line then in a circular path.

7. Six charges $+q$ each are placed at the corners of a regular hexagon of each side a . The electric field at the centre of the hexagon is
 - a) zero
 - b) $\frac{1}{4\pi\epsilon_0} \cdot \frac{q}{a^2}$
 - c) $\frac{1}{4\pi\epsilon_0} \cdot \frac{6q}{a^2}$
 - d) $\frac{1}{4\pi\epsilon_0} \cdot \frac{3q}{a^2}$

8. A charge q is placed at the centre of an imaginary cubical body. Electric flux through any one of its faces is
 - a) $\frac{q}{\epsilon_0}$
 - b) $\frac{6q}{\epsilon_0}$
 - c) $\frac{q}{6\epsilon_0}$
 - d) $\frac{q}{3\epsilon_0}$

9. An electric dipole is placed at the origin parallel to x-axis. The angle made by the electric field with the x-axis at a point whose position vector makes an angle 60° with the x-axis is
 - a) 60°
 - b) 30°
 - c) 0°
 - d) 90°

10. Electric field intensity at a point varies as r^{-3} for
 - a) a point charge
 - b) an electric dipole
 - c) a line charge of infinite length
 - d) a plane infinite sheet of charge.

11. At the mid point of an electric dipole
 a) electric field is zero

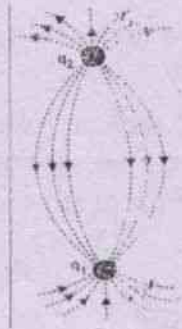

- b) electric potential is zero
 c) both electric field and potential are zero.
 d) both electric field and potential are not zero.
12. The electric potential at a point distant r from an electric dipole is proportional to

- a) $\frac{1}{r}$ b) $\frac{1}{r^2}$

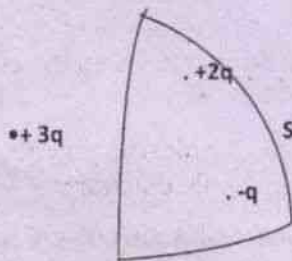

- c) $\frac{1}{r^3}$ d) r
13. The potential of a charged spherical conductor of radius r is 10 V. The potential at a point $r/2$ from its centre is
 a) 20 V b) 0
 c) 10 V d) 40 V
14. The electric field intensity on the surface of a charged spherical conductor of radius r is E . Its value at a point $r/2$ from

its centre is

- a) $4E$ b) E
 c) $2E$ d) 0
15. A hollow spherical conductor of radius $2m$ carries a charge of 1 nc . The electric potential at the centre of the spherical conductor is
 a) 0 b) 4.5 V
 c) 1.5 V d) 2.25 V
16. Proton has a mass of 1840 times that of an electron. If a proton is accelerated from rest by a p.d. of 1 volt, its kinetic energy is
 a) 1840 eV b) 1 eV
 c) 1 meV d) 0
17. A cloud is at a potential of 8×10^6 volts relative to the ground. A charge of 40 C is transferred in a lightning stroke between the cloud and the ground. The energy dissipated is
 a) $5 \times 10^{-6} \text{ J}$ b) $3.2 \times 10^{-7} \text{ J}$
 c) $3.8 \times 10^8 \text{ J}$ d) $3.2 \times 10^8 \text{ J}$
18. The electric potential v as a function of distance x (in meter) is given by

$$V = (2x^2 + 5x - 9) \text{ volt}$$
 The value of electric field at $x = 1 \text{ m}$ would be
 a) 9 V/m b) -9 V/m
 c) -7 V/m d) -2 V/m
19. Charges of $\frac{10}{3} \times 10^{-9}$ coul are placed at each of the four corners of a square of sides 8 cm each. The potential at the intersection of its two diagonals is
 a) $900 \sqrt{2}$ b) 900 volt
 c) $150 \sqrt{2}$ d) $1500 \sqrt{2} \text{ volt}$

20. When a charge of 3 Coul is placed in a uniform electric field it experiences a force of 3000 N. The potential difference between two points separated by a distance of 1 cm within this field is

- a) 10 volt b) 90 volt
c) 1000 volt d) 3000 volt

B. Very Short Answer Type Questions :

- Define electric field.
- State whether a charge is affected by its own field.
- What do you understand by electric field?
[CHSE 98 A]
- An electric dipole is enclosed within a Gaussian surface. What is the electric flux through that surface?
- What do you mean by Gaussian surface?
- How does the electric field at a point due to an electric dipole depend on the distance of the point from the dipole?
[CHSE 98 A]
- What is the electric field at the centre of an equilateral triangle if three identical charges each of charge q are fixed at the three corners of the triangle?
- What is the angle between the directions of electric field strength and dipole moment at any point in (i) end on position and (ii) broad-side on position.
- In a non-uniform electric field, a dipole experiences a torque and a net force. True or false?
- What are the dimensions of (i) dielectric constant and (ii) permittivity?
- What do you mean by a test charge?
- What is the work done by the electric field of a nucleus for a complete rotation of the

electron in circular orbit? What if the orbit is elliptical.

- What is the S.I. unit of line integral of an electric field?
- What is the relation between electric field intensity and potential gradient?
[CHSE 92 A]
- Write the relation between Joule, Volt and Coulomb.
- What is the angle between an equipotential line and an electric line of force at the point of intersection in an electric field.
[CHSE 87 S]
- Express volt in watt and ampere.
[CHSE 89 S]
- A charge of 15 coulomb is sent through an electric lamp when the difference of potential is 120 volt. How much of energy is expended.
[CHSE 99 A]
- Define potential at a point in an electric field.
[CHSE 97 S]
- Will any work be done in moving an electric charge q over the surface of an isolated charged metallic conductor?
[CHSE 96 S]
- What is the electric potential at any point on the dipole equator?
- A sphere of radius 60 cm is charged to a potential of 1500 V. Calculate the charge on the sphere.
[CHSE 99 Instant]
- A point charge is taken from a point A to a point B in an electric field. Does the electric field depend on the path of the charge?
- What is the potential energy of two protons kept at a distance of 0.5 m.
- Name of the physical quantity whose S.I unit is JC^{-1} . Is it a scalar or a vector quantity? [CBSE 2003, 2010, 2000C]

26. Draw lines of force to represent a uniform electric field. [CBSE 1995]
27. Which physical quantity has unit NC^{-1} ? Is it a vector or scalar quantity? [CBSE 2002C]
28. What is an equipotential surface? [CBSE 2003]
29. How much work is done in moving a $500 \mu\text{C}$ charge between two points on an equipotential surface? [CBSE 2002]

C. Short Answer Type Questions :

- Define electric field intensity. Is it a scalar or vector? What is its S.I. Unit?
- Define electric lines of force and state their important properties.
- Why do two electric lines of force not intersect each other? [CHSE 99 A]
- What is an electric dipole? What is electric dipole moment? Define an ideal dipole.
- What is SI unit of electric dipole moment?
- With the help of a diagram, show the lines of force due to an isolated (i) positive charge and (ii) negative charge.
- With the help of a diagram, show the lines of force due to two equal and opposite charges.
- What is the expression for torque on a dipole placed in a uniform electric field?
- What is the minimum electrostatic potential energy of an electric dipole of moment \vec{p} in a uniform electric field \vec{E} .
- State Gauss's law of electrostatics.
- What is electrostatic shielding? Give at least one practical application.

[The electric field inside a charged conductor is zero. This effect is called electrostatic shielding. During a thunderstorm accompanied by lightning, it is safest to be inside a car, rather than near a tree or open ground because the interior field is zero, regardless of charge imparted by lightning to the body of the car.]

- A charge is released in a uniform electric field. Does it gain kinetic energy? If so what is the nature of the graph between gain in kinetic energy versus time?
- What do you mean by electric flux? What is its unit? How is it related to flux density?
- What is the electric field inside a charged conductor? Plot a graph between electric field strength E and distance from centre in case of a charged conducting sphere of radius R .
- A bird perches on a bare highpower line but nothing happens to it, while a man standing on the ground suffers a shock on touching the same line. Why?
- What is the equipotential surface for the following
 - a single positive charge at the origin
 - a uniform electric field parallel to z -axis.
- State the properties of equipotential lines. [CHSE 96 S]
- Convert 1 stat volt into volt. [CHSE 96 S]
- Draw in the same graph the curves showing the variation of electric field and potential due to a point charge with distance. [CHSE 94 A]
- Why do equipotential lines not intersect each other?
- Two conducting spheres of radius 1 cm

- and 2cm are equally charged. What is the ratio of their potentials ?
22. There are two conducting spheres of radii r_1 and r_2 . Find (i) ratio of charges on them if both of them are at the same potential (ii) ratio of potential if charge on them are equal. [CHSE 2001]
 23. Will a solid metal sphere hold a larger charge than hollow sphere of same diameter? Where does the charge reside in each case ? [CHSE 99 A]
 24. Is there any lower limit to produce an electric potential at a point at a distance of 1.0 meter from a charged particle ? If so find the same.
 25. The work done in carrying a charge of $5\mu\text{C}$ from a point A to B is 8 mJ. Find the difference of potential between A and B.
 26. Consider the situation shown in the figure. What are the signs of q_1 and q_2 ? [CBSE 2002C]
 27. Draw an equipotential surface for a system of two charges q , $-q$ separated by a distance r in air. [CBSE AI 2008]
 28. An electrostatic field line cannot be discontinuous. Why ? [CBSE 2005]
 29. Fig. below shows three point charges $+2q$, $-q_2$ and $+3q$. Two charge $+2q$ and $-q$ are enclosed within a surface S. What is electric flux due to this configuration through the surface S ? [CBSE Delhi 2010]
 30. An electric dipole of dipole moment 20×10^{-6} C.m is enclosed by a closed surface. What is the net electric flux coming out of this surface ? [CBSE 2005]
- D. Numerical Problems :**
1. Find electric field intensity in which an electron experiences a force equivalent to its own weight. ($m_e = 9.1 \times 10^{-31}$ kg)
 2. Three small spheres each carrying a charge q are placed on the circumference of a circle of radius r to form an equilateral triangle. Find the electric field at the centre of the circle.
 3. Three charges each equal to $1\mu\text{C}$ are placed at the three corners of a square of side 1.0 m. Find electric field at the fourth corner.
 4. A charged particle of mass 5 gm and charge $1\mu\text{C}$ is in limiting equilibrium on a horizontal table when a horizontal electric field of 10^4 NC^{-1} is applied. Find the coefficient of friction between the table and the particle ($g=10\text{ms}^{-2}$).
 5. Find electric field intensity due to an electric dipole of moment 16.9×10^{-7} Cm at a distance of 12 cm from its centre on its equator if the length of the dipole is 10cm.
 6. A charge of $106.2 \mu\text{C}$ is placed at the centre of a cube. Find electric flux through one of its faces.
 7. A charge of $300 \mu\text{C}$ experiences a force of 3N when placed in a uniform electric field. Find the potential difference between two points separated by a distance of 1cm
 - (a) along the electric line of force and
 - (b) perpendicular to the line of force.
 8. Two metal plates have a potential difference of 150 V and are 5 mm apart. A charged particle of mass 1.96×10^{-15} kg is held in equilibrium between the plates. Find the charge on the particle.
 9. 10^{-9} C of charge is distributed over two concentric hollow spheres of radii 1 cm and 2cm such that surface densities of charges are equal. Find the potential at their common centre.
 10. If 27 identical rain drops having identical charges such that potential of each drop is 2.0 volt combine to form a big drop, what will be its potential.

11. Calculate the potential energy of a system composed of four charges of $30 \mu\text{C}$ each that are placed at the four corners of a square of each side equal to 1.0 m .
12. Two charges $5 \mu\text{C}$ and $-20 \mu\text{C}$ are kept 1.0 m apart. Find the point in between these two charges where potential is zero.
- 13 (i) Two point charges $4Q$ and Q are separated by a distance 1 m in air. At what point on the line joining the charges is the electric field intensity zero? (ii) Also calculate the electrostatic potential energy of the charge if $Q = 2 \times 10^{-7} \text{ C}$.

[CBSE AI 2008C]

14. Two point charges A and B of value $+5 \times 10^{-9} \text{ C}$ and $+3 \times 10^{-9} \text{ C}$ respectively are kept 6 cm apart in air. Calculate the work done when charge B is moved by one cm towards charge A. [CBSE 2000]
15. A charge of $10 \mu\text{C}$ is given to a hollow metallic sphere of radius 0.1 m . Find the potential at (i) the outer surface of the sphere and (ii) the centre of the sphere.

[CBSE 1999,1995]

16. A point charge $17.7 \mu\text{C}$ is located at the centre of the cube of side 0.03 m . Find the electric flux through each face of the cube. [CBSE 1997]

E. Long Answer Type Questions :

1. What do you mean by electric field? Give Faraday's concept of electric field. Find an expression electric field intensity due to a point charge.
2. Show that motion of a charged particle when it is projected at right angles to uniform electric field is parabolic.
3. Derive an expression for potential energy of an electric dipole in an electric field.
4. Find an expression for the torque experienced by an electric dipole in a

uniform electric field. What is the work done in rotating a dipole in a uniform electric field from an angle θ_1 to θ_2 where θ_1 and θ_2 are the angles made by dipole moment with the uniform electric field.

5. What is an electric dipole? Obtain an expression for the field due to electric dipole at a point on the equatorial line.

[CHSE 98 A]

6. What is an ideal electric dipole? Find the electric field intensity at a point in the end on position of a dipole. [CHSE 94 A]

7. State and prove Gauss's theorem in electrostatics. Apply this theorem to find electric field near a plane sheet of charge.

8. State and explain Gauss's theorem in electrostatics. Apply this theorem to derive Coulomb's law.

9. What do you mean by Gaussian surface? What is the Gaussian surface for a line charge? Apply Gauss's theorem to find an expression for electric field near a line charge of linear charge density λ .

10. State and explain Gauss theorem in electrostatics. Apply it to derive an expression for the intensity of the field due to a charged plane lamina.

[CHSE 2002A]

11. Define electric potential at a point due to a charge and derive an expression for it.

Four charges $+2C$, $-2C$, $+2C$ and $-2C$ are placed at the four corners of a square ABCD respectively. Find the resultant potential at the point of intersection of two diagonals.

[CHSE 96 A]

12. Define potential gradient and establish a relation between potential gradient and electric field intensity.

- Two point charges $1.2 \mu\text{C}$ and $-8.0 \mu\text{C}$ are placed 500 mm apart. Determine the position where the electric field is 0.
13. State the principle of superposition of potentials. Find an expression for the potential at a point due to an electric dipole on its axis if P is the electric dipole moment.
 14. Define electrostatic potential energy. Derive an expression for it due to a system of two charges.
 15. What do you mean by equipotential line. State the properties of equipotential lines. Show that electric lines of force and equipotential lines are mutually perpendicular to each other.
 16. Define electric potential. What are its unit and dimensions. Show that the potential at a point on the equatorial line of a dipole is zero.

F. True-False Type Questions :

1. Two electric lines of force do not cross each other.
2. A metal sphere of radius 1 cm can hold a charge of 1 coulomb.
3. Two copper spheres of same radii, one hollow and the other solid are charged to same potential. Both will hold same charge.
4. A small metal ball is suspended in a uniform electric field with the help of an insulated thread. If high energy X-ray beam falls on the ball, the ball will be deflected in the direction of the field.
5. If there is no electric field in a given space, a point in that space can have a non-zero potential.
6. A charged particle, free to move in an electric field moves along an electric lines of force.
7. There is no electric field inside a cylindrical conductor when a steady current passes through it.
8. A charged body cannot attract another uncharged body.
9. In an electric field an electron moves away from higher potential to lower potential.
10. Electrons in a conductor have no motion in the absence of a potential difference across it.
11. In space electric potential is zero because electric field does not exist there.
12. Two conductors have equal amount of positive charge and volume. Therefore, they must be of same electric potential.

G. Fill in Blank Type

1. The insulation property of air breaks down at an intensity of electric field of 3×10^6 volts / m. The maximum charge given to a sphere of diameter is.....
2. The electric field strength due to an insulated charge Q at a distance r is.....
3. The electric potential due to an insulated charge Q at a distance r is.....
4. When a charged conductor is placed near an earth connected conductor its potential always.....
5. The electrostatic force \vec{F} on a charge ' q ' placed in an electric field \vec{E} is
6. The electric field intensity at the surface of a charged conductor is
7. If the electric field is uniform in a region, then electric lines of force in that region are

8. The electric field strength due to a dipole at an axial point is proportional to
 9. The electric potential at a point, distant r from an electric dipole is proportional to.....
 10. The relation between electric potential and electric field strength is
- H. Correct the following sentences :**
1. The electric field strength at a point due to an isolated charge varies inversely as the cube of its distance from the point.
 2. Electric field is a scalar quantity.
 3. The S.I unit of electric field strength is N/C^2 .
 4. Electric field intensity at a point is equal to the potential gradient at that point.
 5. Two electric lines of force cross each other at a suitable point.
 6. Equipotential lines and the lines of force intersect at 60° at each other.
 7. Two different equipotential lines intersect each other at a suitable point.

ANSWERS

A. Multiple Choice Type Questions :

1. (c) 2. (d) 3. (b) 4. (d) 5. (b) 6. (c) 7. (a) 8. (c)
 9. (d) 10. (b) 11. (b) 12. (b) 13. (c) 14. (d) 15. (b) 16. (b)
 17. (d) 18. (b) 19. (d) 20. (a)

D. Numerical Problems :

1. $5.6 \times 10^{-11} \text{NC}^{-1}$
 2. 0
 3. $17.2 \times 10^3 \text{NC}^{-1}$, 45° with one of the sides at the fourth corner
 4. $\mu = 0.2$ [Hint : $\mu mg = Eq$]
 5. $6.9 \times 10^6 \text{NC}^{-1}$
 6. $2 \times 10^6 \text{N m}^2 \text{C}^{-1}$
 7. a) 100 V b) 0 V
 8. $6.4 \times 10^{-19} \text{C}$
 9. 540 V
 10. 18 V
 11. 43.9 J
 12. 0.2 m from $5\mu\text{C}$
 13. $(2/3)$ m from charge $4Q$, $1.44 \times 10^{-3} \text{J}$,
 14. $4.5 \times 10^{-7} \text{J}$, 15. $9 \times 10^5 \text{V}$, 9×10^5 ,
 16. $3.33 \times 10^6 \text{Nm}^2/\text{C}$
- F. (1) True (2) False (3) True (4) True (5) True ($E_x = -\frac{dv}{dx} = 0$ if V is constant) (6) False (7) False (8) False (9) False (10) False (11) False (12) False.
- G. (1) $2 \times 10^{-3} \text{C}$ (2) $\frac{1}{4\pi\epsilon_0} \frac{Q}{r^2}$ (3) $\frac{1}{4\pi\epsilon_0} \frac{Q}{r}$ (4) decreases (5) $q\vec{E}$ (6) normal to the surface
 (7) parallel (8) $\frac{1}{r^3}$ (9) $\frac{1}{r^2}$ (10) $E_r = -\frac{dv}{dr}$

3

Capacitance

3.1 Capacitor :

A device in which electric charge can temporarily be stored is called a capacitor or a condenser.

A capacitor consists of two conductors of any shape and size well insulated from each other separated by a small distance with empty space or any dielectric medium between them. These conductors are oppositely charged so as to have a potential difference and thereby store electrical energy. This energy is readily recovered by allowing charge to flow between them through various electrical devices. Depending on the shape of the conductors and dielectric material used capacitors are of several types such as parallel plate capacitor, spherical capacitor, cylindrical capacitor, paper capacitor, ceramic capacitor etc.

3.2 Simple capacitor :

A simple capacitor consist of two large metal sheets insulated from each other and their surroundings and placed close together with empty space between them. If a device for moving a charge through a potential difference such as a battery is connected to these plates, electrons are driven from one plate to the other making one plate positively charged while the other negatively charged. The charges on the two plates are equal in magnitude but opposite in nature. As the charges are accumulated in small instalments under the repulsive force of

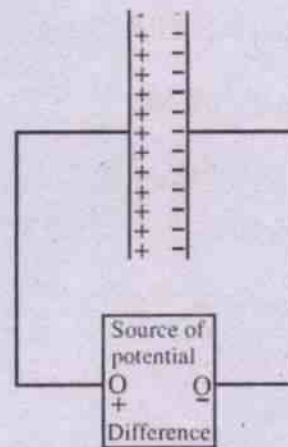

Fig. 3.1

already existing charges on the plates, work is to be done to put more and more charge. This work done is stored as electrostatic potential energy in the electric field of the capacitor which can be drawn through an electrical device. Thus one of the functions of a capacitor is to store electrical energy and supply it whenever it is needed such as in rectifiers, amplifiers and numerous electronic devices.

3.3 Capacitance :

When an isolated conductor of any shape is given a charge, it acquires a potential proportional to the charge q given to it :

$$q \propto V$$
$$\text{or } q = CV \quad \dots(3.3.1)$$

where C is a constant of proportionality and is known as capacity or capacitance of the conductor.

Eqn. (3.3.1) may be written as

$$C = \frac{q}{V} \quad \dots(3.3.2)$$

If $V = 1$, $C = q$

Capacitance of a conductor is numerically equal to the quantity of charge required to raise the potential of the conductor by one unit.

A capacitor can never be full with charges. More and more charges can be accumulated by the capacitor by continuously increasing its potential until it breaks down. A fair analogy to capacitor is an air tank. More and more air can be put in by increasing the pressure until the tank bursts.

3.4 Units of capacitance :

In honour of Michael Faraday, the unit of capacitance in SI system is named as farad.

$$\frac{1 \text{ Coulomb}}{1 \text{ volt}} = 1 \text{ farad (F)}$$

A farad is the capacitance of a capacitor which acquires a potential difference of one volt when it receives a charge of one Coulomb.

The unit, farad is very large. Most frequently used unit is microfarad (μF). ($\mu\text{F} = 10^{-6} \text{ F}$). In some cases picofarad (pF) is a convenient unit ($\text{pF} = 10^{-12} \text{ F}$).

Cgs (esu) unit of capacitance is stat-farad. *Astat-farad is the capacitance of a capacitor which acquires a potential of one stat volt when it receives a charge of one stat coulomb.*

$$\frac{1 \text{ stat coulomb}}{1 \text{ stat volt}} = 1 \text{ stat farad}$$

$$\begin{aligned} 1 \text{ farad} &= \frac{1 \text{ C}}{1 \text{ V}} = \frac{3 \times 10^9 \text{ stat coul}}{\frac{1}{300} \text{ stat volt}} \\ &= 9 \times 10^{11} \text{ stat farad.} \end{aligned}$$

3.5 Dimensions of capacitance

$$[C] = \frac{[q]}{[V]} = \frac{[q]}{[w/q]}$$

$$= \frac{[q^2]}{[w]} = \frac{[Q^2]}{[ML^2T^{-2}]}$$

$$[C] = [M^{-1}L^{-2}T^2Q^2]$$

$$= [M^{-1}L^{-2}T^4A^2] \because \{[Q] = [AT]\}$$

Example

A capacitor gets a charge of $30 \mu\text{C}$ when it is connected to a cell of 1.5 V . Calculate the capacitance of the capacitor.

Solution

Given $q = 30 \times 10^{-6} \text{ C}$, $V = 1.5 \text{ V}$, $C = ?$

$$C = \frac{q}{V} = \frac{30 \times 10^{-6}}{1.5} = 20 \mu\text{F}$$

3.6 Capacitance of an isolated spherical conductor :

Consider an isolated spherical conductor of radius r . Let it be given a charge q . This charge gets uniformly distributed throughout its conducting surface. The potential at any point on its surface can be obtained by considering the charge q being concentrated at its centre. Hence the potential at any point on its surface is

$$V = \frac{q}{4\pi \epsilon_0 r}$$

Therefore, the capacitance of the spherical conductor is

$$C = \frac{q}{V} = 4\pi \epsilon_0 r \quad \dots(3.6.1)$$

Thus the capacitance of a spherical conductor is proportional to its radius.

Example

Assuming earth to be a spherical conductor of radius 6.4×10^6 m, find its capacitance.

Solution

Given $r = 6.4 \times 10^6$ m, $C = ?$

$$C = 4\pi \epsilon_0 r$$

$$= \frac{6.4 \times 10^6}{9 \times 10^9} = 711 \mu\text{F}$$

3.7 Capacitance of a parallel plate capacitor :

Parallel plate capacitor consists of two large parallel metal sheets X and Y insulated from each other and their surroundings. They are kept close to each other with empty space between them.

Let each sheet of metal plate have an area A and separated by a distance d. One of the plates X is given a charge +q while the other plate Y, -q by a battery B.

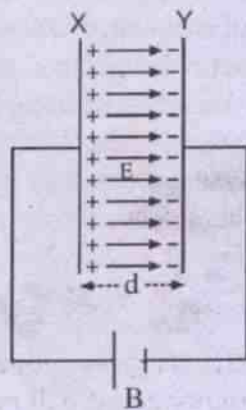

Fig. 3.2

The electric field inside the parallel plate capacitor is uniform and is given by

$$E = \frac{\sigma}{\epsilon_0} = \frac{q}{\epsilon_0 A} \quad \dots(3.7.1)$$

when $\sigma = \frac{q}{A}$ is the surface density of charge.

The potential difference between the two plates is given by negative line integral of electric field as

$$V_Y - V_X = -\int_0^d \vec{E} \cdot d\vec{r} = -\int_0^d E dr = -Ed$$

The p.d. between two plates is

$$V = V_X - V_Y = Ed \quad (\because V_X > V_Y)$$

$$V = Ed = \frac{qd}{\epsilon_0 A} \quad \dots(3.7.2)$$

The capacitance of a parallel plate capacitor in free space is

$$C_0 = \frac{q}{V} = \frac{\epsilon_0 A}{d} \quad \dots(3.7.3)$$

When the space between two parallel plates of the capacitor is filled with a dielectric of permittivity ϵ and dielectric constant K, its new capacitance is

$$C = \frac{\epsilon A}{d} \quad \dots(3.7.4)$$

$$= \frac{K \epsilon_0 A}{d} \quad \dots(3.7.5)$$

Thus capacitance of a parallel plate capacitor is directly proportional to the common area between the plates, directly proportional to permittivity of the medium between the plates and inversely proportional to the distance between the plates.

From eqn. (3.7.5) it is clear that, when a parallel

plate capacitor is filled with a dielectric of dielectric constant K , its capacitance increases K times. Hence it enables us to measure the dielectric constant of a dielectric :

$$K = \frac{C}{C_0} \quad \dots(3.7.6)$$

3.8 Parallel plate capacitor partly filled with a dielectric :

Suppose a dielectric slab of dielectric constant K and thickness t ($t < d$) is kept in between the two plates of the charged capacitor as shown in the Fig. (3.3).

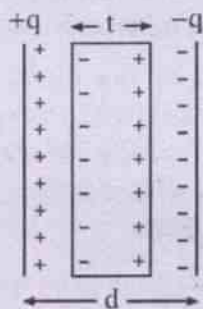

Fig. 3.3

The net thickness of air gap between the plates is now $(d - t)$.

The electric field intensity inside the air gap is

$$E_0 = \frac{\sigma}{\epsilon_0} = \frac{q}{\epsilon_0 A} \quad \dots(3.8.1)$$

and inside the dielectric the electric field is

$$E = \frac{\sigma}{\epsilon_0 K} = \frac{q}{\epsilon_0 KA} \quad \dots(3.8.2)$$

where $\sigma = \frac{q}{A}$ is the surface charge density, q is the magnitude of charge on each plate of area A . Note that both E_0 and E are in the same direction.

Potential difference between the two plates of the capacitor is given by the eqn. (3.7.2)

as

$$\begin{aligned} V &= E_0(d-t) + Et \\ &= \frac{q}{\epsilon_0 A}(d-t) + \frac{q}{\epsilon_0 KA}t \\ &= \frac{q}{\epsilon_0 A} \left[(d-t) + \frac{t}{K} \right] \quad \dots(3.8.3) \end{aligned}$$

The capacitance of a parallel plate capacitor when it is partly filled with a dielectric is given by (using eqn. 3.8.3)

$$C_{pd} = \frac{q}{V} = \frac{\epsilon_0 A}{d-t + \frac{t}{K}} \quad \dots(3.8.4)$$

i) When the capacitor is partly filled with a metal slab of thickness t instead of dielectric slab, its capacitance, using eqn. (3.8.4), is given by

$$C_{pm} = \frac{\epsilon_0 A}{d-t} \quad \dots(3.8.5)$$

Since for metals $K = \infty$

Comparing eqns. (3.8.4) and (3.8.5) we note that

$$C_{pm} > C_{pd}$$

Comparing eqns. (3.7.3) and (3.8.5) we note that introduction of a metal slab inside a capacitor is equivalent to decrease in distance between the two plates by the amount of thickness of the metal slab. Moreover by its insertion, breakdown voltage of the capacitor decreases. Hence to increase the capacitance of the capacitor, a dielectric medium is preferred to metal slab.

ii) When the parallel plate capacitor is completely filled with a metal slab ($t = d$)

$$C_{fm} = \infty$$

In this case electric charges continuously flow through the capacitor and it will never be full with charges. The capacitor is now short

circuited. A short circuited capacitor will have infinite capacitance.

iii) When the parallel plate capacitor is completely filled with a dielectric slab (i.e. $t=d$) of dielectric constant K ,

$$C_{fd} = \frac{\epsilon_0 A}{d/K} = K \frac{\epsilon_0 A}{d} = KC_0$$

where C_0 is the capacitance of air filled capacitor.

Example

Find the capacitance of a parallel plate capacitor having plates of area 10 cm^2 separated by a distance of 2.0 mm in free space.

Solution

$$\text{Given } A = 10 \text{ cm}^2, d = 0.2 \text{ cm}$$

Capacitance of the parallel plate capacitor

$$\begin{aligned} C &= \frac{\epsilon_0 A}{d} \\ &= \frac{8.85 \times 10^{-12} \times 10 \times 10^{-4}}{0.2 \times 10^{-2}} \\ &= 4.43 \times 10^{-12} \text{ F} \\ &= 4.43 \text{ pF.} \end{aligned}$$

Example

A $10 \mu\text{F}$ parallel plate capacitor is connected across a 2 volt battery. If the separation between the plates is doubled then how will the (i) capacitance (ii) potential difference across the plates, and (iii) charge change.

Solution

$$\text{Given } C = 10 \mu\text{F}, V = 2 \text{ volt}$$

$$\text{i) } C = \frac{\epsilon_0 A}{d}, C' = \frac{\epsilon_0 A}{2d} = \frac{C}{2} = 5 \mu\text{F}$$

ii) Since battery is connected, p.d. remains the same as 2 volt .

$$\text{iii) } q = CV = 10 \times 2 = 20 \mu\text{C}$$

$$q' = C'V = 5 \times 2 = 10 \mu\text{C}$$

Capacitance will be halved, potential difference remains the same and charge will be halved.

3.9 Dielectric and its effects :

Dielectric materials are insulators and they are loosely called as dielectrics. No substance is a perfect insulator. In a steady electric field the conductivity of many insulators is so small that, it can be neglected as a first approximation.

In some capacitors air is used as a dielectric medium but in many other capacitors solid and liquid dielectrics such as mica, parafined paper, oil etc. are used.

Function of the dielectric used in a capacitor is two fold. (1) It has good insulating property and (2) it increases the capacitance of the capacitor by a large factor evident from the following discussion.

Substances have two types of molecules viz., polar molecules and non polar molecules. Polar molecules have permanent electric dipole moments whereas non-polar molecules acquire dipole moments in the presence of electric field. In the absence of electric field the polar molecules of the dielectric are randomly oriented (fig. 3.4(a)) due to thermal agitation, and hence net electric field produced by them is zero.

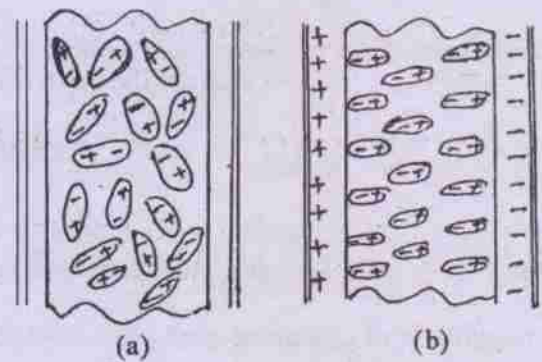

[Fig. 3.4 Dielectric material in a capacitor (a) uncharged (b) charged]

Fig. 3.4

When a capacitor is charged, the resulting electric field causes the elementary (molecular or atomic) dipoles of polar substances to align their dipole moments in the direction of electric field (fig. 3.4(b)) whereas in non polar substances dipole moments are induced by a small displacement of positive charge of the molecules in the direction of electric field and negative charge opposite to the direction of electric field. *The phenomenon of alignment of elementary dipole-moments in the case of polar substances and induction of dipole-moments in non polar substances is known as dielectric polarization.* The amount of polarization depends on (i) strength of the electric field and (ii) nature of the dielectric. Polarization does not produce any net charge in the body of the dielectric but it results in a sheet of positive charge on one face (near the negatively charged plate of the capacitor) of the dielectric and a sheet of negative charge (near positively charged plate of the capacitor) on the other face as shown in fig. 3.4.(b). Thus the electric field due to dielectric polarization is opposite to the external electric field which causes the polarization. Thereby electric field inside the dielectric weakens, potential difference across the capacitor decreases and hence capacitance of the capacitor increases.

Let E be the electric field due to the charge on the capacitor and E_i be electric field due to polarization of the dielectric. Net electric field inside the polarized dielectric is $(E - E_i)$.

Potential difference across the capacitor

i) in the absence of dielectric is
 $V = Ed$

and ii) in the presence of dielectric is
 $V_d = (E - E_i)d$

Capacitance of the capacitor

i) with air as the medium $C_o = \frac{q}{V} = \frac{q}{Ed}$
and ii) with a dielectric as the medium

$$C = \frac{q}{V_d} = \frac{q}{(E - E_i)d}$$

$$\text{Dielectric constant } K = \frac{C}{C_o} = \frac{E}{E - E_i}$$

Thus, if an electric field applied to a dielectric is E , electric field inside the dielectric is

$$(E - E_i) = \frac{E}{K}$$

We can also define dielectric constant of a dielectric as the ratio of external electric field applied to the dielectric to the electric field inside the dielectric. Also because electric field inside a conductor is 0, K has to be ∞ for a conductor.

The effect of keeping a dielectric inside a charged parallel plate capacitor is

- i) dielectric gets polarized
- ii) Electric field decreases to E/K
- iii) Potential difference across the capacitor decreases to V/K
- iv) Capacitance of the capacitor increases K times.

Example

A $30 \mu\text{F}$ parallel plate capacitor is fully charged with a battery of emf 6 volts and then the battery is disconnected. If the separation between the plates is 3.0 cm, find (i) electric field intensity in the space between the plates and (ii) charge of the capacitor. Now a dielectric of dielectric constant 3 is introduced. Find (iii) electric field inside the dielectric (iv) charge on the capacitor (v) potential difference across the capacitor (vi) capacitance of the capacitor.

Solution

Given : $C = 30 \mu\text{F}$, $V = 6$ volt, $d = 3 \times 10^{-2}$ m

$$\text{i) } E = \frac{V}{d} = \frac{6}{3 \times 10^{-2}} = 200 \text{ V/m}$$

$$\text{ii) } q = CV = 30 \times 6 = 180 \mu\text{C}$$

$$\text{iii) } E_d = \frac{E}{K} = \frac{200}{3} = 66.7 \text{ V/m}$$

$$\text{iv) } q = KC \times \frac{V}{K} = 180 \mu\text{C}$$

$$\text{v) } V_d = \frac{V}{K} = \frac{6}{3} = 2 \text{ volt}$$

$$\text{vi) } C_d = KC = 3 \times 30 = 90 \mu\text{F}$$

3.10 Dielectric strength :

It is clear from the eqn. $C = \frac{q}{V}$ that charge accumulated in a capacitor is not limited by its capacitance. Potential difference across the capacitor builds up with increase in charge. However a dielectric can withstand upto a certain potential gradient beyond which its insulating property gets destroyed and it conducts electricity damaging the capacitor.

Dielectric strength is the ability of a dielectric to withstand a maximum potential gradient without rupture or disruptive discharge of electricity through the dielectric.

Example

A spherical metallic conductor of radius 3.0 cm is held in air. Find the maximum charge it can hold if dielectric strength of air is 30 kv/cm.

Solution

Given : $E = 30 \times 10^5 \text{ V/m}$, $r = 3 \times 10^{-2} \text{ m}$
Electric field strength on the surface of the conductor

$$E = \frac{q}{4\pi \epsilon_0 r^2}$$

$$\text{or } q = 4\pi \epsilon_0 r^2 E$$

$$= \frac{9 \times 10^{-4} \times 30 \times 10^5}{9 \times 10^9}$$

$$= 0.3 \mu\text{C}$$

3.11 Combinations of capacitors :

Two or more capacitors can be connected in several ways. The two most important ways of connecting a group of capacitors are the series and parallel combinations. Each combination behaves as a single capacitor. Let us calculate its equivalent capacitance.

i) Series combination :

Capacitors are said to be connected in series if second plate of first capacitor is connected to first plate of second capacitor, the second plate of second capacitor to first plate of third capacitor and so on as shown in the fig. (3.5)

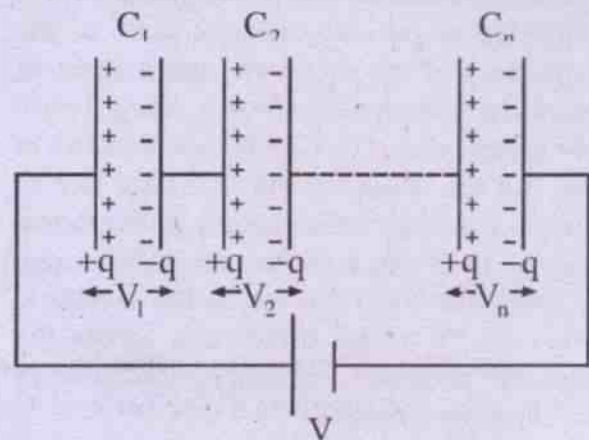

Fig. 3.5

Let the series combination, consisting of n capacitors of capacities C_1, C_2, \dots, C_n be connected across a battery of emf V . The battery supplies a charge $+q$ to the first plate of capacitor C_1 and the charge $-q$ is induced on the inner surface of its second plate while its free charge $+q$ flows to the first plate of second capacitor C_2 . The above process is repeated until the last capacitor C_n is reached (Fig 3.5). Thus each of the capacitor holds same quantity of charge q irrespective of the value of the capacitance. Potential difference across each capacitor

depending on their capacities, is different. Let V_1, V_2, \dots, V_n represent potential differences across the different capacitors of different capacities C_1, C_2, \dots, C_n respectively and V be the potential difference across the series combination.

$$\text{Hence } V = V_1 + V_2 + \dots + V_n \quad \dots(3.11.1)$$

$$\text{where } V_1 = \frac{q}{C_1}, V_2 = \frac{q}{C_2}, \dots, V_n = \frac{q}{C_n}$$

$$\text{and } V = \frac{q}{C} \quad \dots(3.11.2)$$

where C is the equivalent capacitance of the series combination. Substituting eqn. (3.11.2) in eqn. (3.11.1) we have

$$\frac{q}{C} = \frac{q}{C_1} + \frac{q}{C_2} + \dots + \frac{q}{C_n}$$

$$\text{or } \frac{1}{C} = \frac{1}{C_1} + \frac{1}{C_2} + \dots + \frac{1}{C_n} \quad \dots(3.11.3)$$

In series combination of capacitors, the reciprocal of equivalent capacitance of the combination is equal to the sum of the reciprocals of the individual capacitances.

ii) Parallel combination :

Capacitors are said to be connected in parallel if one of the plates of each capacitor is connected to a common point (A) while the other plates are connected to another common point (B) as shown in the fig. 3.6.

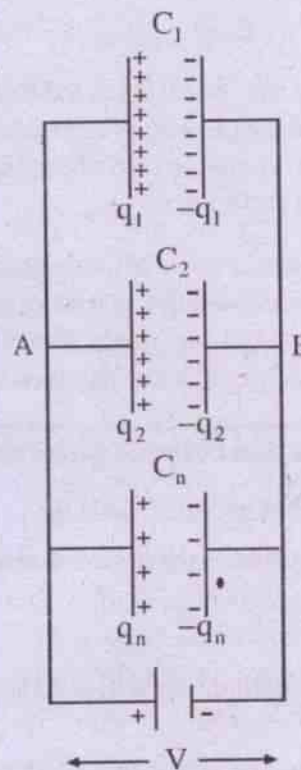

Fig. 3.6

Let the parallel combination consisting of n capacitors of capacities C_1, C_2, \dots, C_n be connected across a battery of emf V . Evidently all the capacitors are charged to same potential since they are all connected directly to same source of emf V . Charges on each capacitor are different and are given by

$$q_1 = C_1 V, q_2 = C_2 V, \dots, q_n = C_n V \quad \dots(3.11.4)$$

The total charge q of the combination supplied by the battery is equal to sum of the charges on individual capacitors.

$$\text{Hence } q = q_1 + q_2 + \dots + q_n \quad \dots(3.11.5)$$

If C represents the equivalent capacitance of the parallel combination, $q = CV$ and substituting eqn. (3.11.4) in eqn. (3.11.5) we have,

$$CV = C_1V + C_2V + \dots + C_nV$$

$$\text{or } C = C_1 + C_2 + \dots + C_n \quad \dots(3.11.6)$$

Thus, in parallel combination of capacitors, the equivalent capacitance of the combination is equal to sum of the capacitances of individual capacitors.

When one or more of the capacitors cannot sustain a desired voltage, a series combination of such capacitors are used. The voltage per capacitor in such a series combination is inversely

proportional to the capacitance of the capacitor i.e. capacitor of least capacitance has the largest voltage across it. As an example, suppose a capacitor can sustain maximum of 10 volts. When desired voltage to be applied is 100 volts, a minimum of 10 such capacitors can be joined in series so that the entire voltage (100V) across the combination will be distributed and each capacitor now will have a potential difference of 10 volts. When a large capacitance is desired at low or moderate potential, parallel combination of capacitors are used. Such a combination will hold a large charge.

3.12 Distinction between series and parallel combination of capacitors :

Series combination

1. Charge on each capacitor is same.
2. Series combination will hold less charge.
3. Potential difference of different capacitors is different
4. Potential of the source is distributed among different capacitors of the combination. The one having largest capacitance will have smallest potential difference.
5. The reciprocal of equivalent capacitance of the series combination is equal to sum of the reciprocals of their individual capacitances.
6. The equivalent capacitance is smaller than smallest individual capacitance of the combination.
7. Series combination of capacitors is used when one or more of the capacitors can not withstand the entire applied voltage.

Parallel combination

- Charge on different capacitors is different. The capacitor having large capacity will accumulate more charge.
- Parallel combination will hold a large charge.
- Potential difference across each capacitor is same.
- Charge supplied by the source is distributed. The one having greatest capacitance will hold largest amount of charge.
- The equivalent capacitance of parallel combination is equal to sum of their individual capacitance.
- The equivalent capacitance is larger than largest individual capacitance of the combination.
- Parallel combination of capacitors is used when a large capacitance is desired at a moderate or low potential.

Example :

The capacitance of two capacitors are in the ratio 1 : 4 on joining them in series the equivalent capacitance is $4 \mu\text{F}$. Find the capacitance of each capacitor.

Solution :

$$\text{If } C_1 = C, C_2 = 4C$$

The equivalent capacitance of the series combination is $C_s = \frac{C_1 C_2}{C_1 + C_2} = \frac{4C}{5}$

$$\therefore \frac{4C}{5} = 4$$

$$\therefore C = C_1 = 5\mu\text{F}, C_2 = 4C = 20\mu\text{F}.$$

Example :

n identical capacitors are first joined in parallel and then in series. Find the ratio of their equivalent capacitances.

Solution :

Let C be the capacitance of each capacitor The equivalent capacitance of the parallel combination is

$$C_p = nC$$

and $C_s = \frac{C}{n}$

$$\therefore C_p : C_s = n^2 : 1$$

Example :

Find the equivalent capacitance between the points A and B in the fig. (3.7)

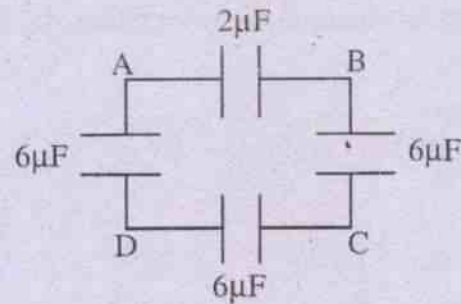

Fig. 3.7

Solution :

Three $6 \mu\text{F}$ capacitors are in series.

$$\therefore C_s = \frac{6}{3} = 2\mu\text{F}$$

C_s is in parallel with $2 \mu\text{F}$ capacitor.

\therefore The equivalent capacitance of the combination is $2 + 2 = 4 \mu\text{F}$

3.13 Electrostatic potential energy stored in a charged capacitor :

To charge a capacitor, work is done by an external agency (e.g. battery). This work done is stored in the electric field of the capacitor as electrostatic potential energy. It can be recovered as heat energy when the two charged plates are connected by a resistance wire. Thus *energy of a charged capacitor is defined as the work done to charge the capacitor.*

Consider a capacitor of capacitance C given a charge Q under a potential difference of V . Q and V are the final values after the capacitor is fully charged. During the process of charging let q and v be the instantaneous values of charge and p.d. of the capacitor respectively. If a further charge dq is given to the capacitor, work done against the potential difference v is

$$\begin{aligned} dW &= v dq \\ &= \frac{q}{C} dq \quad \dots(3.13.1) \end{aligned}$$

Total work done in charging the capacitor from 0 to Q is obtained by integrating the eqn. (3.13.1)

$$\int_0^W dW = \int_0^Q \frac{q}{C} dq$$

or
$$W = \frac{1}{C} \int_0^Q q dq$$

or
$$W = \frac{Q^2}{2C} \quad \dots(3.13.2)$$

$\therefore Q = CV$

$$W = \frac{Q^2}{2C} = \frac{1}{2} CV^2 = \frac{1}{2} QV \quad \dots(3.13.3)$$

3.14 Energy density of an electric field :

The capacitance of a parallel plate capacitor in free space is given by the eqn. 3.7.3 as

$$C_0 = \frac{\epsilon_0 A}{d}$$

and the electric field intensity between the two plates of the charged capacitor is

$$E = \frac{V}{d} \text{ or } V = Ed$$

$$\therefore W = \frac{1}{2} CV^2 = \frac{1}{2} \frac{\epsilon_0 A}{d} \cdot E^2 d^2 = \frac{1}{2} \epsilon_0 E^2 Ad \quad \dots(3.14.1)$$

$Ad = v$ is the volume of the space between the two plates of the capacitor.

Thus, the energy stored per unit volume in an electric field intensity E or energy density of an electric field is

$$u = \frac{W}{v} = \frac{1}{2} \epsilon_0 E^2 \quad \dots(3.14.2)$$

Expression for energy density eqn. (3.14.2) is independent of shape and size of the capacitor. Hence, whether the electric field is due to a

capacitor or otherwise, energy density of an electric field in free space is $\frac{1}{2} \epsilon_0 E^2$.

If $E = 0$, energy density $u = 0$.

Thus, energy is stored in the electric field. If the electric field is established in a dielectric medium of permittivity ϵ , the energy density

$$u = \frac{1}{2} \epsilon E^2 = \frac{1}{2} K \epsilon_0 E^2 \quad \dots(3.14.3)$$

where K is the dielectric constant.

3.15 Force of attraction between two plates of a charged parallel plate capacitor :

Work done in charging a capacitor can be considered to be equivalent to mechanical work done in pulling apart two oppositely charged plates each of plate area A , slowly to increase the separation from 0 to d . If F is the force of attraction between the plates

$$W = Fd = \frac{q^2}{2C} = \frac{1}{2} \epsilon_0 E^2 Ad$$

(Using eqns. 3.13.3 and 3.14.1)

$$Fd = \frac{q^2 \times d}{2 \times \epsilon_0 A} = \frac{1}{2} \epsilon_0 E^2 Ad$$

$$\therefore F = \frac{q^2}{2A \epsilon_0} = \frac{\sigma^2 A}{2 \epsilon_0} = \frac{1}{2} \epsilon_0 E^2 A \quad \dots(3.15.1)$$

where σ is the surface density of charge.

Example :

A parallel plate capacitor of capacitance $8\mu\text{F}$ is connected to a power supply of 50 V. If the separation between the two plates is 5mm and area of each plate is 2 cm^2 find (i) energy of the capacitor (ii) energy density in the electric field and (iii) force of attraction between the plates.

Solution :

Given $C = 8 \times 10^{-6} \text{ F}$, $V = 50 \text{ volt}$

$A = 2 \times 10^{-4} \text{ m}^2$, $d = 5 \times 10^{-3} \text{ m}$

i)
$$W = \frac{1}{2} CV^2 = \frac{1}{2} \times 8 \times 10^{-6} \times 50 \times 50$$

$$= 0.01 \text{ J}$$

ii)
$$u = \frac{W}{v} = \frac{W}{A \cdot d} = \frac{0.01}{2 \times 10^{-4} \times 5 \times 10^{-3}}$$

$$= 1 \times 10^4 \text{ J/m}^3$$

iii)
$$F = \frac{W}{d} = \frac{0.01}{5 \times 10^{-3}} = 2 \text{ N}$$

3.16 Capacitance of a spherical capacitor :

A spherical capacitor consists of a solid or a hollow spherical conductor surrounded by another concentric hollow spherical conductor. One of the spherical conductors is given a charge while the other is earthed.

i) *When the outer sphere is earthed*

Consider two concentric metallic spheres A and B of radii a and b respectively. Let the inner sphere be given a positive charge $+q$ while the outer sphere B be earthed.

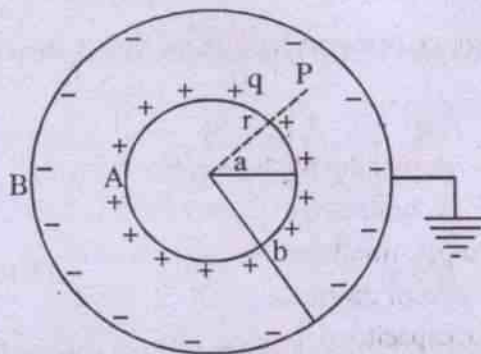

Fig. 3.8

Now $-q$ bound charge is induced on the inner surface of B while its $+q$ free charge flows into the earth as it is earthed.

Electric field strength at a point P at a distance r from the centre O and within the concentric spheres is entirely due to the charge $+q$ on the inner sphere and is given by

$$\vec{E} = \frac{1}{4\pi \epsilon_0} \cdot \frac{q}{r^2} \hat{r}$$

where \hat{r} is the unit vector along \vec{OP} .

The potential difference between two spheres is given by

$$V = - \int_b^a \vec{E} \cdot d\vec{r}$$

$$= - \int_b^a \frac{1}{4\pi \epsilon_0} \cdot \frac{q}{r^2} \hat{r} \cdot d\vec{r}$$

$$= - \frac{q}{4\pi \epsilon_0} \int_b^a \frac{dr}{r^2}$$

$$= \frac{q}{4\pi \epsilon_0} \left[\frac{1}{r} \right]_b^a$$

$$= \frac{q}{4\pi \epsilon_0} \left[\frac{1}{a} - \frac{1}{b} \right] \dots(3.16.1)$$

The capacitance of the spherical capacitor is given by

$$C = \frac{q}{V} = \frac{q}{\frac{q}{4\pi \epsilon_0} \left[\frac{1}{a} - \frac{1}{b} \right]} = 4\pi \epsilon_0 \frac{ab}{b-a} \dots(3.16.2)$$

Special cases :

a) *Capacitance of spherical conductor :*

Spherical capacitor becomes spherical conductor if radius of the outersphere is considered to be infinity. The eqn. (3.16.2) can

now be written as

$$C = 4\pi \epsilon_0 \frac{a}{1 - \frac{a}{b}} = 4\pi \epsilon_0 a \quad \text{If } b \rightarrow \infty.$$

b) Capacitance of a very large spherical capacitor :

Let the separation between two spheres of the spherical capacitor be, $d = b - a$.

For a very large spherical capacitor $a \approx b$ and $4\pi ab \approx 4\pi a^2 = A$ (area of each sphere)

$$C = 4\pi \epsilon_0 \frac{ab}{b-a} = \frac{A \epsilon_0}{d} \quad \dots(3.16.3)$$

Eqn. (3.16.3) is same as the capacitance of a parallel plate capacitor. Hence a very large spherical capacitor behaves as a parallel plate capacitor.

ii) When the inner sphere is earthed :

Consider a spherical capacitor of which the inner sphere A is earthed while outer sphere B is given a positive charge q .

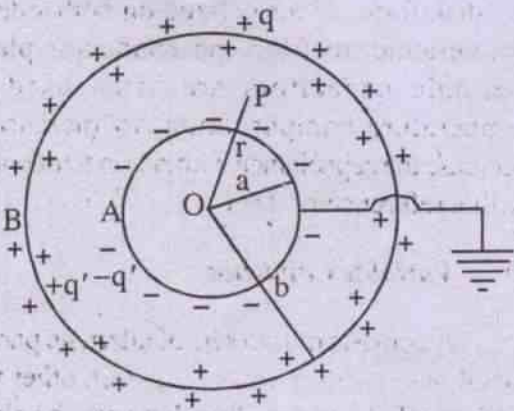

Fig. 3.9

This causes an induced charge $-q'$ to appear on the outer surface of the inner sphere A. This $-q'$ in turn induces $+q'$ on the inner surface of the

outersphere. These induced charges $\pm q'$ must be such that the potential difference between B and A is equal to that of B with respect to earth.

The electric field strength E , at a point P at a distance r from the centre O, in the space between concentric spheres A and B is

$$\vec{E} = \frac{-q'}{4\pi \epsilon_0 r^2} \hat{r}$$

where \hat{r} is the unit vector along \vec{OP} .

Potential difference between the two spheres B and A is

$$V_B - V_A = -\int_a^b \vec{E} \cdot d\vec{r}$$

$$V = V_B = \int_a^b \frac{q'}{4\pi \epsilon_0 r^2} dr$$

(\because the sphere A is earthed $V_A = 0$)

$$= \frac{q'}{4\pi \epsilon_0} \left[-\frac{1}{r} \right]_a^b$$

$$V = \frac{q'}{4\pi \epsilon_0} \left[\frac{1}{a} - \frac{1}{b} \right] \quad \dots(3.16.4)$$

The potential of the outer sphere B relative to earth is given by

$$V = \frac{q}{4\pi \epsilon_0 b} \quad \dots(3.16.5)$$

From eqns. (3.16.4) and (3.16.5) it is clear that

$$\frac{q'}{4\pi \epsilon_0} \left[\frac{1}{a} - \frac{1}{b} \right] = \frac{q}{4\pi \epsilon_0 b}$$

$$\text{or } q' = q \frac{a}{b-a} \quad \dots(3.16.6)$$

Total charge on the outer sphere B is $q+q'$.

The capacitance of the spherical capacitor when the inner sphere is earthed is

$$C = \frac{q + q'}{V}$$

$$= \frac{q}{V} + \frac{q'}{V}$$

using eqns. 3.16.5 and 3.16.4, we have

$$C = 4\pi \epsilon_0 b + 4\pi \epsilon_0 \frac{ab}{b-a} \quad \dots(3.16.7)$$

$$= 4\pi \epsilon_0 \frac{b^2}{b-a} \quad \dots(3.16.8)$$

Comparing eqns. (3.16.7) and (3.16.2) we note that the capacitance of the spherical capacitor when inner sphere is earthed is greater by $4\pi \epsilon_0 b$ to that when outer sphere is earthed. Still then outer sphere earthed capacitor is preferred because of shielding effect which makes its capacity independent of the effect of external charge.

3.17 Types of capacitors :

Types of capacitors are named according to the dielectric used in them. Most common are air, paper, mica, ceramic and electrolytic capacitors.

a) Mica Capacitors

A number of tin foils (or copper plates) are arranged one above the other in such a way that between any two successive tin foils mica sheets are stacked. Alternate strips of tin foil are

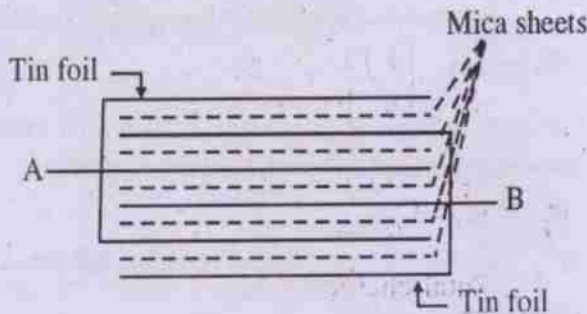

[Fig. (3.10) Mica Capacitor]

connected together and brought out as one terminal A for one set of foils, while the other terminal B connects to other set of foils (Fig. 3.10) The entire unit is generally in a moulded bakelite case. If N is the total number of tin foils, capacitance of the entire unit is $(N-1)C$ where C is the capacitance between two successive tin foils with mica as dielectric between them. This type of capacitor is used in high frequency circuits as energy loss in the mica dielectric is minimum.

b) Paper Capacitor :

It consists of two rolls of tin foils separated by a tissue paper insulator, rolled into a compact cylinder. Two terminals, are taken out from the tin foils on the two sides of the role. The entire cylinder is generally placed in a cardboard container coated with wax or encased in plastic. (fig. 3.11)

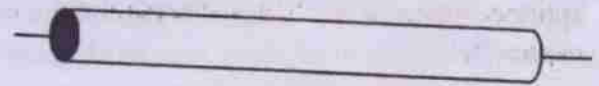

Fig. 3.11

c) Ceramic Capacitor :

Ceramic dielectric materials are made of titanium dioxide or several types of silicates. In the disk form, silver is fixed on both sides of the ceramic, to form the conductor plates. Ceramic capacitors are often used for temperature compensation, to increase or decrease the capacitance with rise in temperature with a reference of $25^{\circ}C$.

d) Variable Capacitor :

It consists of two sets of alternate parallel metal plates without touching each other with air as the dielectric medium between the plates. One set of alternate plates are fixed and connected together to form the stator. The other set of alternate plates connected together on the shaft of the rotor. (fig. 3.12)

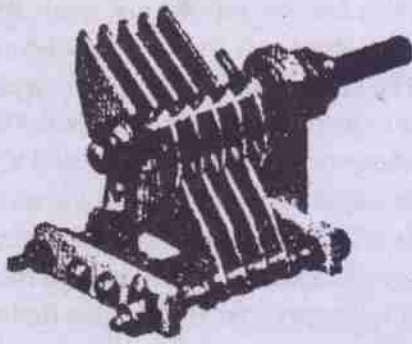

Fig. 3.12

The capacitance can be varied at will by rotating the shaft. Variable capacitor is commonly used as a tuning capacitor in radio receivers.

e) **Electrolytic capacitor :**

It consists of two aluminum electrodes. A cotton gauze soaked in electrolyte of borax is kept in between these electrodes. While manufacturing the capacitor, a d.c. voltage is applied. Electrolytic action accumulates a molecular-thin layer of aluminium oxide at the junction between the positive aluminium electrode and the electrolyte. Since oxide film is an insulator, the positive aluminium electrode and electrolyte acts as a capacitor while negative aluminium electrode simply provides a connection to the electrolyte. Electrolytic capacitor has a large capacitance as the thickness of dielectric film is very small.

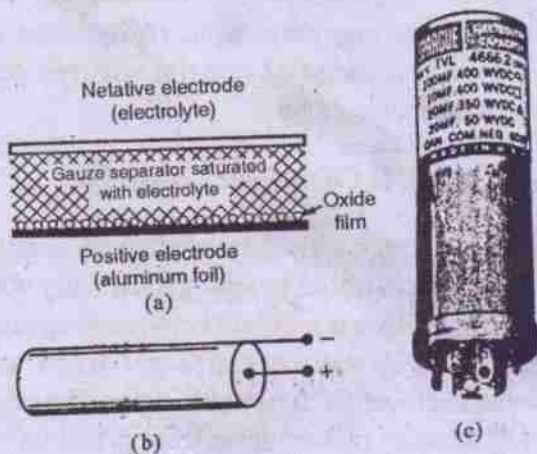

Fig. 3.13

Fig (3.13. a,b,c) shows construction and appearance of a typical electrolytic capacitor.

Its electrical connection should be in such a way that its oxide plate is always positive with respect to the other. Otherwise the reversed electrolysis forms gas and the capacitor becomes hot and may explode. The possibility of explosion is there only for electrolytic capacitors.

Electrolytic capacitors are used in circuits that have a combination of d.c. voltage and a.c. voltage. The d.c. voltage maintains the polarity. It is used to eliminate a.c ripples in d.c power supply.

SUMMARY

A capacitor consists of two conductors separated by a dielectric. Its ability to store charge is known as capacitance. The capacitance of a capacitor is defined by $C = \frac{q}{V}$.

The unit of capacitance is the Farad. One Farad of capacitance stores one Coulomb of charge when applied voltage is one volt. Practical capacitors have much smaller capacitance values, from 1 pF to 1000 μ F.

$$1\text{pF} = 10^{-12}\text{F}, 1\mu\text{F} = 10^{-6}\text{F}.$$

A parallel plate air capacitor has a capacitance given by

$$C = \frac{\epsilon_0 A}{d}$$

A spherical conductor has a capacitance

$$C = 4\pi \epsilon_0 r$$

A spherical capacitor consists of two concentric metal spheres. Its capacitance is

i) $C = 4\pi \epsilon_0 \frac{ab}{b-a}$ when its outer sphere is earthed.

ii) $C = 4\pi \epsilon_0 \frac{b^2}{b-a}$ when its inner sphere is earthed.

where a and b are radii of inner and out spheres of the capacitor respectively.

The dielectric strength of a material is the minimum potential gradient that will cause a disruptive discharge.

When capacitors are connected in series

$$V = V_1 + V_2 + V_3 + \dots$$

$$q = q_1 = q_2 = q_3 = \dots$$

$$\frac{1}{C} = \frac{1}{C_1} + \frac{1}{C_2} + \frac{1}{C_3} + \dots$$

when capacitors are connected in parallel

$$V = V_1 = V_2 = V_3 = \dots$$

$$q = q_1 + q_2 + q_3 + \dots$$

$$C = C_1 + C_2 + C_3 + \dots$$

A charged capacitor possesses energy in its electric field given by

$$W = \frac{1}{2} CV^2 = \frac{1}{2} qV = \frac{1}{2} \frac{q^2}{C} = \frac{1}{2} \epsilon_0 E^2 A d$$

In an isolated charged parallel plate capacitor, when a dielectric of dielectric constant K is inserted its

- i) Capacitance increases K times
- ii) Charge on the plates remains same.
- iii) Potential difference across the plates decreases by a factor $\frac{1}{K}$.
- iv) Electric field decreases by a factor $1/K$.
- v) Energy decreases by a factor $1/K$.

When a parallel plate capacitor is connected to

a battery and a dielectric of dielectric constant K is introduced between the plates of the capacitor, its

- i) Capacitance increases K times.
- ii) Charge q increases to Kq .
- iii) Potential difference across the plates remains the same.
- iv) Electric field between the plates remains the same.
- v) Energy increases K times.

Capacitance of parallel plate capacitor partly filled with dielectric is

$$C = \frac{\epsilon_0 A}{d - t + \frac{t}{K}}$$

where ' t ' is the thickness of the dielectric.

The most common types of commercial capacitors are air, paper, mica, ceramic and electrolytic. Electrolytic capacitors are the only capacitors with polarity.

SOLVED NUMERICAL EXAMPLES :

1. In the circuit shown in the fig. (3.14), $E_1 = 10V$, $E_2 = 17V$, $C_1 = 4\mu F$ and $C_2 = 5\mu F$. Find the potential difference across each capacitor.

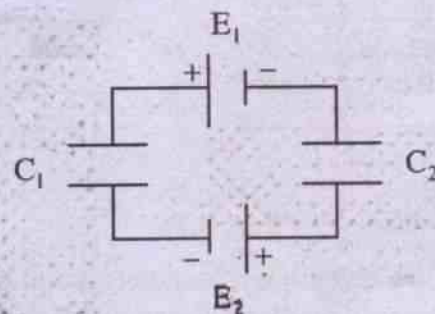

Fig. 3.14

Solution :

The equivalent circuit of the given circuit can be drawn as shown in the fig. (3.15)

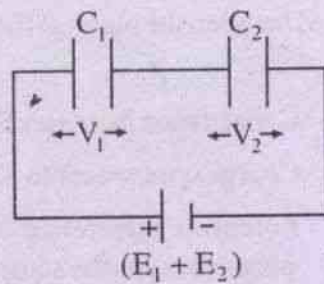

Fig. 3.15

In series combination of capacitors

$$q = C_1 V_1 = C_2 V_2$$

$$\frac{V_1}{V_2} = \frac{C_2}{C_1}$$

$$\frac{V_1}{V_1 + V_2} = \frac{C_2}{C_1 + C_2}$$

$$V_1 = (E_1 + E_2) \frac{C_2}{C_1 + C_2}$$

$$(\because E_1 + E_2 = V_1 + V_2)$$

$$= 27 \times \frac{5}{9} = 15V$$

$$V_2 = 27 - 15 = 12V$$

2. Four identical plates are placed at equal distances as show in the fig. (3.16 a) and fig. (3.16 b). Find the capacitance of the

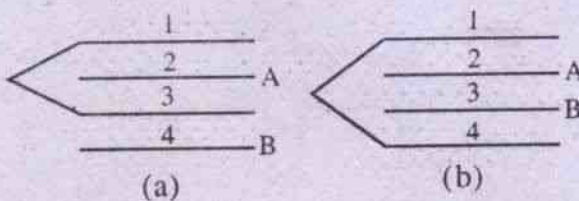

Fig. 3.16

system between the points A and B if the capacitance between any two successive plates is C,

Solution :

The equivalent circuit of fig. (3.16 a) is fig. (3.17 a)

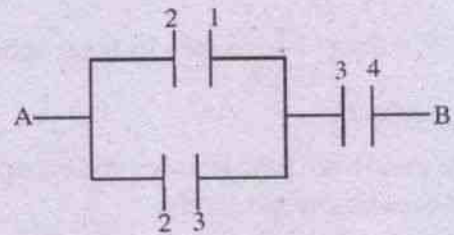

Fig. 3.17 (a)

$$C_{\text{eff}} = \frac{C \times 2C}{C + 2C} = \frac{2}{3}C$$

The equivalent circuit of fig (3.16 b) is fig. (3.17. b)

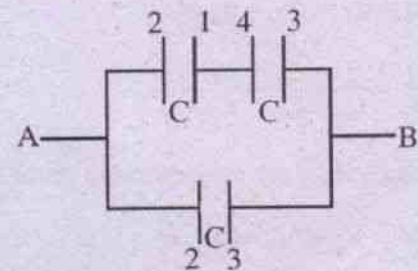

Fig. 3.17 (b)

$$C_{\text{eff}} = \frac{C}{2} + C = \frac{3}{2}C$$

3. Calculate the ratio of the capacitances of two identical parallel plate capacitors when they are filled with two dielectrics of same dimensions but of different dielectric of dielectric constants K_1 and K_2 respectively in the two possible arrangements.

Solution :

The two possible arrangements are (a) and (b) of fig. (3.18)

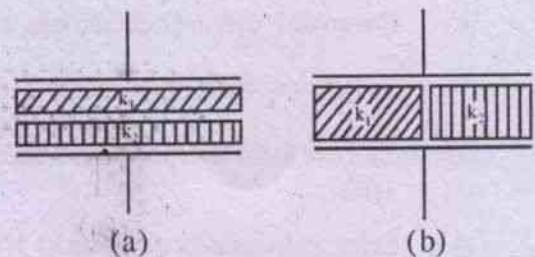

Fig. 3.18

In the arrangement (a) the two capacitors are connected in series.

$$\therefore \frac{1}{C_1} = \frac{d/2}{K_1 \epsilon_0 A} + \frac{d/2}{K_2 \epsilon_0 A}$$

or
$$C_1 = \frac{2 \epsilon_0 A}{d} \times \frac{K_1 K_2}{K_1 + K_2}$$

In the arrangement (b) two capacitors are connected in parallel.

$$\begin{aligned} \therefore C_2 &= \frac{\epsilon_0 \frac{A}{2} K_1}{d} + \frac{\epsilon_0 \frac{A}{2} K_2}{d} \\ &= \frac{\epsilon_0 A (K_1 + K_2)}{2d} \end{aligned}$$

The ratio of the capacitances in these two arrangements is

$$\frac{C_1}{C_2} = \frac{4K_1 K_2}{(K_1 + K_2)^2}$$

4. A $1 \mu\text{F}$ capacitor and $2 \mu\text{F}$ capacitor are connected in series across 1200 V supply line. (a) Find the charge on each capacitor and potential difference across each capacitor. (b) The charged capacitors are disconnected from the supply line and from each other and reconnected with terminals of like sign together. Find the final charge on each and voltage across each.

Solution :

a)
$$C_{\text{eff}} = \frac{C_1 \times C_2}{C_1 + C_2} = \frac{1 \times 2}{1 + 2} = \frac{2}{3} \mu\text{F}$$

In series connection charge on each capacitor is equal to

$$q = C_{\text{eff}} \cdot V = \frac{2}{3} \times 1200 = 800 \mu\text{C}$$

P.d across C_1 is $V_1 = \frac{q}{C_1} = 800 \text{ V}$

P.d across C_2 is $V_2 = \frac{q}{C_2} = 400 \text{ V}$

- b) In parallel connection, P.d across each capacitor is same and is equal to

$$\begin{aligned} V &= \frac{\text{total charge}}{C_1 + C_2} \\ &= \frac{800 + 800}{1 + 2} = 533.3 \text{ Volts} \end{aligned}$$

Charge on C_1 is $q_1 = VC_1 = 533.3 \mu\text{C}$

Charge on C_2 is $q_2 = VC_2 = 1066.7 \mu\text{C}$.

5. If the capacitance of each capacitor is $1 \mu\text{F}$, find the effective capacitance of infinite ladder net work of capacitors between the points A and B as shown in the fig. (3.19)

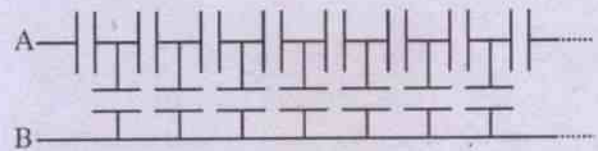

Fig. 3.19

Solution :

Let C be the effective capacitance of the given circuit across the points A and B. As there are infinite pairs of capacitors, adding one more pair of capacitors will not change the effective capacitance of the combination. Thus the equivalent circuit of the fig. (3.19) can be drawn as fig. (3.20)

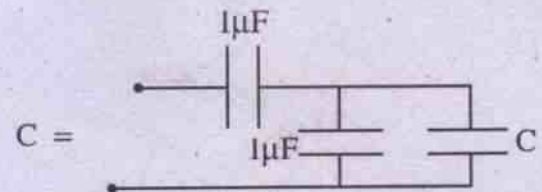

Fig. 3.20

$$\begin{aligned} \therefore C &= \frac{1 \times (C + 1)}{1 + (C + 1)} \\ C(C + 2) &= C + 1 \end{aligned}$$

$$\text{or } C^2 + C - 1 = 0$$

$$\therefore C = \frac{-1 \pm \sqrt{1+4}}{2}$$

$$C = \left(\frac{\sqrt{5}-1}{2}\right) \mu\text{F} \quad (\text{Avoiding negative capacitance})$$

6. A spherical capacitor has radii of inner and outer spheres as 3 cm and 4 cm respectively. The space between two spheres is filled with a dielectric of dielectric constant 3. Find the capacitance of the spherical capacitor when (i) outer sphere is earthed and (ii) the inner sphere is earthed.

Solution :

- i) When the outer sphere is earthed

$$C = 4\pi \epsilon_0 K \frac{ab}{b-a}$$

$$= \frac{3 \times 3 \times 4 \times 10^{-4}}{9 \times 10^9 \times (4-3) \times 10^{-2}} = 40 \mu\text{F}$$

- ii) When the inner sphere is earthed

$$C = 4\pi \epsilon_0 K \frac{b^2}{b-a}$$

$$= \frac{3 \times 4 \times 4 \times 10^{-4}}{9 \times 10^9 \times (4-3) \times 10^{-2}} = 53.3 \mu\text{F}$$

7. n capacitors each of capacitance C are connected as shown in the fig. (3.21). Calculate the equivalent capacitance between the points A and B.

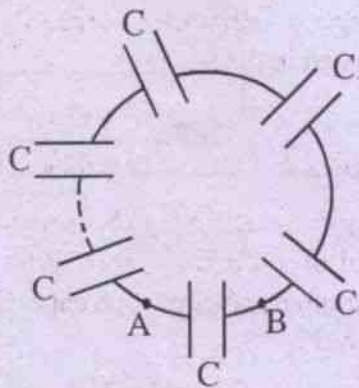

Fig. 3.21

Solution :

Out of n capacitors $(n-1)$ are connected in series combination and its effective capacitance is $\frac{C}{n-1}$.

Capacitance of $\frac{C}{n-1}$ is in parallel with the capacitance C across the points A and B.

$$\therefore \text{Effective capacitance } C_{\text{eff}} = C + \frac{C}{n-1}$$

$$= \frac{nC}{n-1}$$

8. Find the effective capacitance of the circuit between the points A and B in the fig.3.22.

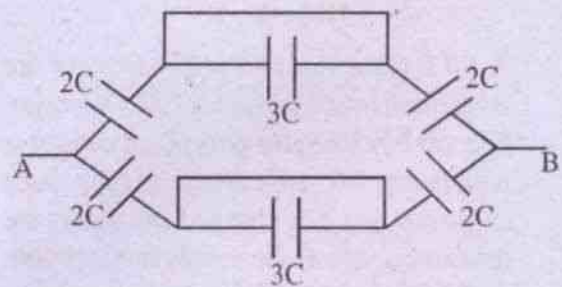

Fig. 3.22

Solution :

In the series circuits, capacitors $3C$ and $3C$ are short circuited. The equivalent circuit of the fig. (3.22) is fig. (3.23) and the effective capacitance across the points A and B is $2C$.

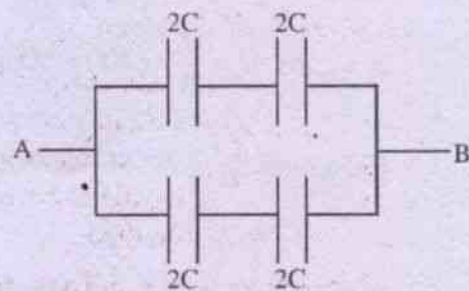

Fig. 3.23

MODEL QUESTIONS

A. Multiple Choice Type Questions :

1. Unit of capacitance is
 - a) Volt
 - b) Coulomb
 - c) ohm
 - d) Farad
2. The capacitance of a capacitor decreases if
 - a) its charge decreases
 - b) its supply voltage increases
 - c) separation between the plates decreases.
 - d) common area of the plates decreases
3. A parallel plate capacitor is charged by a battery and it is then disconnected from the battery. When a dielectric material is inserted between the plate.
 - a) electric field decreases
 - b) potential difference across the capacitor decreases.
 - c) capacitance increases
 - d) All the above are correct
4. Three different capacitors are connected in series and charged by a battery. They will have
 - a) equal charge
 - b) equal potential
 - c) equal charge and equal potential
 - d) unequal charge and unequal potential
5. A parallel plate capacitor is charged by connecting a battery across its plates. If the battery remains connected and a dielectric material is inserted in between the plates of the capacitor, then
 - a) potential difference across the capacitor remains the same.
 - b) Electric field remains the same
 - c) capacitance increases
 - d) All the above
6. The force of attraction between the plates of a parallel plate capacitor of area A and charge q is
 - a) $\frac{q^2 A}{2 \epsilon_0}$
 - b) $\frac{q^2}{2 \epsilon_0 A}$
 - c) $\frac{q^2}{\epsilon_0 A}$
 - d) $\frac{q^2}{4 \epsilon_0 A}$
7. What is the minimum number of capacitors of $1 \mu F$ which can withstand $10V$, are required to construct a capacitor of $1 \mu F$ which can withstand $30V$?
 - a) 3
 - b) 6
 - c) 9
 - d) 1
8. A small mercury drop has a capacitance $1 \mu F$. If 8 such identical drops are combined to form a big drop, its capacitance is
 - a) $8 \mu F$
 - b) $2 \mu F$
 - c) $4 \mu F$
 - d) $1 \mu F$
9. A capacitor of capacitance $2 \mu F$ has been charged to $200V$. It is now discharged through a resistance wire. The heat produced in the wire is
 - a) $4 \times 10^4 J$
 - b) $400 J$
 - c) $0.04 J$
 - d) $0.02 J$
10. $2.25 \mu F$ capacitor is to be formed out of a pool of $1 \mu F$ capacitors. What is the minimum number of such capacitors are required ?
 - a) 6
 - b) 3
 - c) 5
 - d) not possible

B. Very Short Answer Type Questions :

1. What is a capacitor ? [CHSE 99 A]
2. State the unit of capacitance in SI. Is it a practical unit ?
3. State the dimensions of capacitance.
4. A parallel plate capacitor is immersed in water. How will its capacitance change? [CHSE 01]
5. What happens to the capacity of a condenser when a dielectric slab is introduced in the space between its plates. [CHSE 98 A]
6. How does capacity of a capacitor change if the separation between the plates is increased ? [CHSE 97 A]
7. Define one Farad.
8. If two capacitors, each of value $2 \mu\text{F}$, are connected in parallel what is the value of effective capacitance ? [CHSE 94 A]
9. The ratio of maximum equivalent capacitance to minimum equivalent capacitance obtained by grouping three $1 \mu\text{F}$ capacitors in series and parallel combination is _____. [CHSE 96 S]
10. Three $3 \mu\text{F}$ capacitors are connected in series. Its equivalent capacitance is _____.
11. To form a $2.5 \mu\text{F}$ capacitor, how many minimum number of $1 \mu\text{F}$ capacitors are needed ?
12. Two identical metal spheres, one hollow and the other solid are charged to the same potential. Which one will have more charge ?
13. What is the capacitance of a short circuited capacitor ?
14. What will happen to the capacitance of parallel plate capacitor when a metal plate of thickness equal to half the distance between the plates is placed in the middle.

15. Can we give any amount of charge that we like, to a capacitor ?

16. What happens to the energy stored in a capacitor, if the plates of the charged capacitor are moved farther, the battery remaining connected ?

[CBSE Sample Paper]

17. When a capacitor is charged by a battery, does the energy stored by a capacitor remain same as the energy supplied by the battery ? [CBSE Sample Paper]

C. Short Answer Type Questions :

1. What is a dielectric medium ? State its effect on the capacity of a capacitor. [CHSE 97 S]
2. What should be capacity of a condenser to have one joule of energy ? [CHSE 95A]
3. n number of identical capacitors are first connected in series and then in parallel. Find the ratio of equivalent capacitance of two groupings. [CHSE 99 A]
4. What happens to the electric field of a charged capacitor when a dielectric is introduced inside the capacitor and why?
5. Which will have a higher capacity - spherical capacitor when its outer sphere is earthed or inner sphere is earthed. Which one is used and why ?
6. Can a spherical conductor of radius 1.0m hold 1.0C of charge if dielectric strength of air is 10^6 v/m . Why ?
7. If 8 identical drops each charged to energy equal to one erg are combined to form a big drop, the energy of the big drop is _____.
8. A capacitor has a charge of 0.1 C when it is charged through a p.d. of 200 volts. Find heat generated in a resistor when it is connected across the plates of the capacitor.

9. The capacitance of a spherical capacitor is $1.0 \mu\text{F}$. If the spacing between the two spheres is 1mm , find the radius of the outer sphere.
10. A parallel plate air capacitor has capacitance C . When it is half filled with a dielectric of dielectric constant 5, find the increased value of its capacitance.
11. Sketch a graph to show how charge Q given to a capacitor of capacitance C varies with the potential difference?

[CBSE 2000]

12. A charged capacitor has stored energy U_0 . What will be the energy stored when air is replaced by a dielectric of dielectric constant 'k', charge Q remaining same. [CBSE 1997]
13. The given graph shows the variation of charge Q versus potential difference for capacitance C_1 and C_2 . The two capacitors have the same plate separation; but the plate area of C_2 is double that of C_1 . Which of the lines in the graphs correspond to C_1 and C_2 and why?

[CBSE 2006]

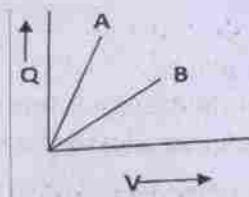

D. Numerical Problems :

1. In a parallel plate uncharged capacitor, by transferring 1.25×10^{13} electrons from one plate to the other a potential difference of 4V is produced. Find the capacitance of the capacitor.
2. To construct a capacitor of $1\mu\text{F}$ having a breakdown voltage of 100V out of $1\mu\text{F}$ capacitors, each having a breakdown voltage of 10V , find (a) minimum number of capacitors required. (b) how they should be connected?
3. Three capacitors having capacities $20\mu\text{F}$, $30\mu\text{F}$ and $60\mu\text{F}$ are connected in series with a 10V battery. Find (a) charge on each capacitor (b) energy stored in each capacitor (c) energy supplied by the battery.
4. A parallel plate capacitor having common plate area 50cm^2 and plate separation 2.0mm is connected to a battery of 6.0V . Calculate the charge on the capacitor and the work done by the battery.
5. Two conducting spheres of radii 4.0cm and 6.0cm have charges $440\mu\text{C}$ and $60\mu\text{C}$ respectively. Calculate the loss of energy when they are connected together by a conducting wire.
6. A capacitor is filled with two dielectrics of same dimensions but of dielectric constants 2 and 3. Find the ratio of the capacitances in the two possible arrangements.
7. A parallel plate capacitor has a certain capacitance. When a dielectric of thickness 4.0mm is inserted and separation of plates increased by 3.0mm , the capacitor regains its original capacitance. Find the dielectric constant of the dielectric.
8. A parallel plate capacitor contains a mica sheet of thickness 1.0mm and a sheet of fibre of thickness 0.5mm . Dielectric constant of mica is 8 and that of the fibre is 2.5. If the fibre breaks down when subjected to electric field of $6.4 \times 10^6\text{V/m}$, find the safe voltage that can be applied to the capacitor.
9. Two capacitors connected in parallel and charged to a p.d. of 100V store an energy of $5 \times 10^{-2}\text{J}$. When they are connected

in series and connected to same p.d. of 100V they store an energy of 1.2×10^{-3} J. Find their capacitances.

10. 720 capacitors each of capacitance $10 \mu\text{F}$ are connected in parallel and charged to a p.d. of 50 KV. Find the cost of charging if electric energy costs Rs. 2.00 per Kwh.
11. Calculate the equivalent capacitance of the combination between p and Q as shown in Fig. below. [CBSE 2000]

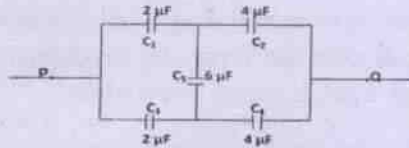

12. Four capacitors are connected as shown in Fig below. Calculate the equivalent capacitance between the points X and Y.

With, $C_1 = 2 \mu\text{F}$, $C_2 = 3 \mu\text{F}$, $C_3 = 5 \mu\text{F}$ and $C_4 = 10 \mu\text{F}$. [CBSE 2000]

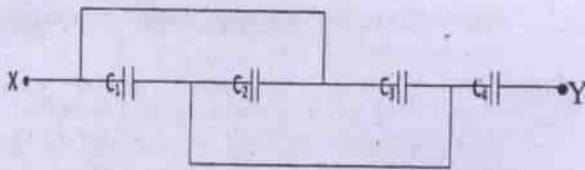

13. Calculate the equivalent capacitance between points A and B for the network of infinite number of capacitors as shown in fig. below with $C = 2 \mu\text{F}$.

[CBSE Sample Paper]

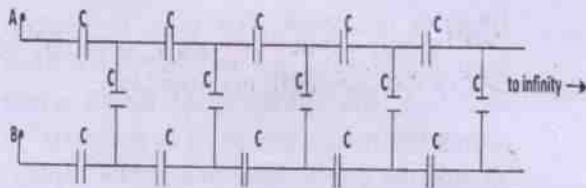

E. Long Answer Type Questions :

1. Derive the laws of combinations of

capacitors connected in series and parallel.

[CHSE 99A, 95A]

2. Define capacitance. What is its unit in S.I. system? Mention its dimensions? Derive an expression for the capacitance of two concentric spheres. [CHSE 94 S,96S]
3. What is a capacitor? Derive an expression for the capacitance of a parallel plate capacitor.
4. Derive an expression for the energy stored in a capacitor. Find an expression for the energy density in an electric field E in free space.
5. What are the different types of capacitors in use. Describe briefly each case giving emphasis on electrolytic capacitor. Can electrolytic capacitor be used in a circuit containing a.c. only.

F. True - False - Type Questions

1. The energy of a capacitor, resides in the field between the plates.
2. Earth can be given unlimited charge.
3. We can give as much charge as we wish to a capacitor.
4. The dielectric constant of a conductor is infinite.
5. When a dielectric is introduced between the plates of a capacitor (1 condenser) at a constant potential difference, the charge on the plates remains unchanged.
6. Two adjacent conductors that carry the same positive charge can have a potential difference between them.
7. Three different capacitors are connected in series and charged by a battery. They will have equal charge.
8. The force of attraction between the plates of a parallel plate capacitor of area A and

charge q is $q^2/2 \epsilon_0 A$.

9. The energy stored in a capacitor is $\frac{1}{2} CV$.
10. The capacitance of a parallel plate capacitor is given as $\epsilon_0 \epsilon_r A/d$, where A is the area of the plates, d is the distance between them.

G. Fill in Blank Type Questions

1. When the condensers are connected in series their capacity.....
2. The equivalent capacitance of the capacitor in series is than the minimum capacitance connected in series.
3. The capacitance of a capacitor when a dielectric medium is filled between the plates.
4. The capacitance of a conductor when an earth-connected conductor is brought near it.
5. Two parallel metal plates carry charge $+Q$ and $-Q$, respectively. A test charge placed between them experiences a force F . Now the separation between them is doubled, then the force on the test charge will be.....
6. The capacitance of a parallel plate condenser does not depend on of the plate.
7. A $2 \mu F$ capacitor is charged to potential $200V$ and then isolated. When it is connected in parallel with a second capacitor which is uncharged, the

common potential becomes $40V$. The capacitance of the second capacitor is μF .

8. The energy stored in a capacitor of capacitance C and holding charge q is.....
9. Two capacitors each of capacitance $1 \mu F$ are connected in parallel. The effective capacitance of the combination is
10. Two capacitors each of capacitance $\frac{1}{2} \mu F$ are connected in series. The effective capacitance of the combination is
11. The capacitance of a spherical conductor is $1 \mu F$. Its radius is

H. Correct the following sentences :

1. Unit of capacitance is coulomb.
2. The capacitance of a parallel plate capacitor of area A , distance of separation between the plates d , is $\epsilon_0 \epsilon_r A/d^2$.
3. Energy stored in a capacitor is $(1/2) CV$.
4. The effective capacitance of three capacitors of capacitance $2 \mu F$ each, and connected in parallel is $(2/3) \mu F$.
5. The radius of a spherical conductor of capacitance $1 \mu F$ is $9 \times 10^4 m$.
6. The capacitance of a capacitor decreases when a dielectric is introduced between the plates.
7. When the capacitors are connected in series their capacitance increases.

ANSWERS

A. Multiple Choice Type Questions :

1. (d) 2. (d) 3. (d) 4. (a) 5. (d) 6. (b) 7. (c) 8. (b)
9. (c) 10. (a)

D. Numerical Problems :

1. $0.5 \mu\text{F}$
2. (a) 100,
(b) In ten rows, each row having 10 capacitors connected in series.
3. (a) $100 \mu\text{C}$, $100 \mu\text{C}$, $100 \mu\text{C}$
(b) $2.5 \times 10^{-4} \text{J}$, $1.67 \times 10^{-4} \text{J}$, $0.83 \times 10^{-4} \text{J}$
(c) $1.0 \times 10^{-3} \text{J}$ (Hint $W = Vq$)
4. $1.33 \times 10^{-10} \text{C}$, $7.97 \times 10^{-10} \text{J}$
5. $1.08 \times 10^4 \text{J}$

$$\text{Hint } \Delta W = \frac{1}{2} \cdot \frac{r_1 r_2}{r_1 + r_2} \cdot \frac{1}{4\pi \epsilon_0} \left[\frac{q_1}{r_1} - \frac{q_2}{r_2} \right]^2$$

6. 24 / 25 Hints

7. $K = 4$

8. 5200 V

[Hint $E = E_1$, $K_1 = E_2$, K_2 , $E_2 = 6.4 \times 10^6 \text{V/m}$, where E is the electric field in free space of the capacitor

$$V_1 + V_2 = E_1 d_1 + E_2 d_2]$$

9. $4 \mu\text{F}$, $6 \mu\text{F}$

10. Rs. 5.0

11. $(8/3)\mu\text{F}$.

12. $5 \mu\text{F}$.

13. $(\sqrt{3} - 1)\mu\text{F} = 0.732 \mu\text{F}$.

- F. (1) True (2) True (3) False (4) True (5) False (6) True (7) True (8) True (9) False (10) True.

- G. (1) decreases (2) Less (3) Increases (4) Increases (5) F (6) Metal (7) $8 \mu\text{F}$ (8) $q^2/2c$ (9)

- $2 \mu\text{F}$ (10) $\frac{1}{4} \mu\text{F}$ (11) $9 \times 10^3 \text{m}$

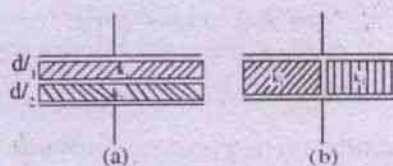

4

Magnetostatics

4.1 Magnets :

Magnetostatics deals with properties of magnets and magnetic materials. Properties and effects of magnets are conveniently studied using the concept of magnetic poles. A magnetic pole plays a role similar to that of electric charge in electrostatics. However, unlike isolated charges, an isolated magnetic monopole does not exist. The property of magnetism by which a piece of magnetite which is an ore of iron attracts small pieces of iron and shows a particular direction when suspended freely, was known as early as 600 B.C.

The property by virtue of which a substance can attract iron filings (magnetic materials) is called magnetism. A body having the property of magnetism is known as a magnet.

There are two types of magnets :

i) *Natural magnets :*

Natural magnets are pieces of a naturally occurring iron ore known as magnetite (Fe_3O_4).

Natural magnets have the following demerits.

- a) They have weak magnetism.
- and b) They have irregular shapes.

ii) *Artificial or permanent magnets :*

These are powerful magnets, made of hard steel or special alloys, prepared in the laboratory. Each atom of these magnets behaves as a small magnet known as an atomic magnet

or elementary magnetic dipole. When these atomic magnets of the substance are randomly oriented forming closed chains, it is unmagnetised. (fig. 4.1 (a)).

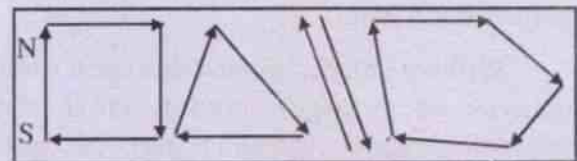

(a) unmagnetised

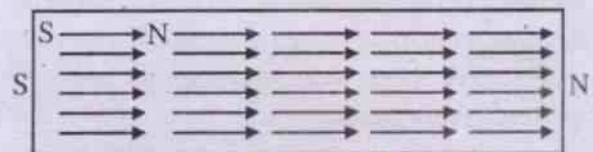

(b) magnetised

Fig. 4.1

When all the atomic magnets of the substance are made to align in one direction artificially, it gets magnetised. (fig. 4.1(b)).

4.2 Properties of a magnet :

Basic properties of a magnet are as follows :

i) *Poles of a magnet :*

Every magnet has two poles known as south pole and north pole. These are situated near the ends of the magnet.

ii) *Attractive property :*

A magnet attracts small pieces of iron. If a bar magnet is dipped in a lump of iron filings,

maximum number of iron filings are attracted at the two regions near the ends of the magnet. The poles are located in these regions. As one goes from these two poles towards the centre of the magnet, number of iron filings sticking to the magnet gradually decreases. This indicates that the attractive power of the magnet is greatest at the two poles.

iii) **Directional property :**

A freely suspended bar magnet or a pivoted magnetic needle always comes to rest in the geographical north-south directions. Depending upon their seeking of geographical directions, poles of a magnet are named i.e. the pole seeking geographical south is named as south pole while the pole seeking geographical north as north pole.

William Gilbert showed that earth itself behaves as a huge magnet. Near the geographical north and south poles of the earth respectively, situated are south and north poles of the earth's magnet. This causes the directional property of the magnets which in turn led to the development of mariner's compass. In good olden days these were extensively used for navigation purposes.

iv) **Nature of force between magnetic poles :**

If two similar poles of two bar magnets are brought near to each other, it is observed that they move away from each other while two dissimilar poles come closer to each other. This shows that like poles repel whereas unlike poles attract.

v) **Poles always exist in pairs :**

Two poles of a magnet can never be separated i.e. a magnetic monopole does not exist. If a magnet is broken into two pieces, each piece behaves as a magnet having two poles. If we go on breaking until the atomic scale is reached, the atom behaves as a magnet known as an atomic dipole. Even subnuclear particles have magnetic dipole moments but a monopole

does not exist. However, scientists are probing the existence of magnetic monopoles. Incidentally, two electric poles i.e. positive and negative charges of an electric dipole can easily be separated. Thus an electric monopole has independent existence whereas a magnetic monopole does not exist.

4.3 **Bar magnet :**

A magnet in the shape of a rod or a bar is called a bar magnet. Its two poles appear near its ends. Pole strength is designated by m . Its unit is weber (Wb) or A-m. The distance between the south pole and the north pole is called as magnetic length, usually denoted by 2ℓ . The magnetic length 2ℓ is found to be 84% of its geometric length. (fig. 4.2)

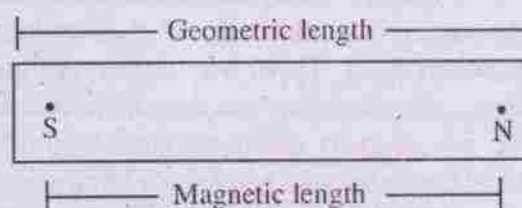

Fig. 4.2

Magnetic moment (M) of a bar magnet is defined as the product of its pole strength and magnetic length.

$$\vec{M} = 2m\vec{\ell} \quad \dots(4.3.1)$$

Magnetic moment is a vector quantity. Its direction is from south pole to north pole. Its unit is A-m² or Wb-m or J T⁻¹ (Joul per tesla).

4.4 **Magnetic dipole :**

A combination of two opposite magnetic poles of equal strength separated by a small distance is called a magnetic dipole. Pole strength of south and north poles are represented by $-m$ and $+m$ respectively similar to the charges of electric dipole.

4.5 **Magnetic field :**

Magnetic field of a magnet is the modified region of space surrounding it, in which any

other magnetic pole brought in experiences a force.

Consider a region free of magnetic field. If a magnetic pole is placed in this region, it will not experience any force but it will modify the property of the region in such a way that if any other magnetic pole is placed in this region it will experience a force. This modified region of space due to the presence of a magnetic pole or a magnet is known as magnetic field.

4.6 Magnetic lines of force :

A magnetic field is pictorially represented by magnetic lines of force similar to the representation of electric field by electric lines of force. No such lines of force exist in reality.

A magnetic line of force is defined as a line, straight or curved, such that the tangent to it at any point gives the direction of magnetic field at that point.

Due to an isolated pole alone, lines of force are straight whereas due to a magnet, the lines of force are curved (Fig. 4.3).

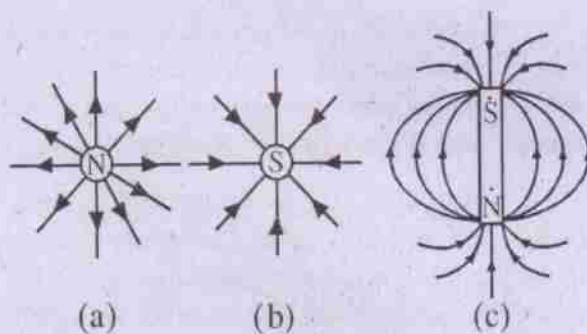

Fig. 4.3

[Magnetic lines of force due to (a) North pole
(b) South pole (c) Bar magnet]

Arrow head on the lines of force gives the direction in which a free north pole assumed to be left on a line of force moves.

In the regions where lines of force enter or leave the magnet, magnetic poles are located.

4.7 Properties of magnetic lines of force :

- i) They are continuous curves.
- ii) They leave from N-pole and enter at S-pole and continue inside magnet upto the north pole making closed curves (unlike electric lines of force).
- iii) The tangent at any point on the line of force gives the direction of magnetic field at that point.
- iv) Two lines of force do not intersect each other. If so, at the point of intersection, two tangents can be drawn giving two directions of the magnetic field (at a point) which is impossible.
- v) Lines of force are crowded in the region of strong magnetic field whereas they are widely separated in the region of weak magnetic field.

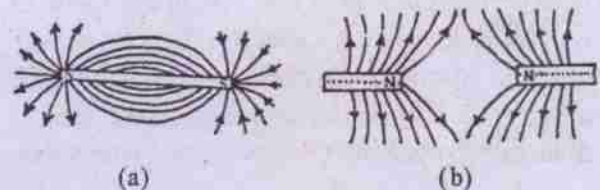

Fig. 4.4

4.8 Coulomb's law of magnetism :

Although monopole does not exist, the idea of isolated magnetic poles is quite useful to understand the concepts of magnetism like Coulomb's law.

Coulomb's law states that the force of attraction or repulsion between two magnetic poles is directly proportional to the product of their pole strengths and inversely proportional to the square of the distance between them.

Let m_1 and m_2 be the pole strength of two magnetic poles separated by a distance r . According to Coulomb's law, the force (of

attraction between unlike poles and repulsion between like poles) between them is given by

$$F \propto m_1 m_2$$

$$\propto \frac{1}{r^2}$$

Combining these two relations, we have

$$F \propto \frac{m_1 m_2}{r^2}$$

$$\text{or } F = K \frac{m_1 m_2}{r^2} \quad \dots(4.8.1)$$

where K is a constant of proportionality. Its value depends on the medium between the poles and the system of units chosen.

4.9 Coulomb's law in different system of units :

There are two ways in which the value of K in eqn. (4.8.1) can be specified. One way is to define a unit pole and obtain the value of K . This is done in c.g.s. electromagnetic system of units. Alternatively choosing the value of K a unit pole can be defined therefrom. This is done in S.I. system:

i) Coulomb's law in c.g.s. (emu) system :

A unit pole in cgs-emu system is defined as one which exerts a force of one dyne on another identical pole placed at a distance of 1cm in free space from it.

Mathematically,

$$F = 1 \text{ dyne, if } m_1 = m_2 = 1 \text{ unit, } r = 1 \text{ cm}$$

Eqn. (4.8.1) gives

$$1 = K \frac{1 \cdot 1}{1^2}$$

$$\text{or } K = 1$$

Thus in cgs system coulomb's law of magnetism can be written as

$$F = \frac{m_1 \cdot m_2}{r^2} \quad \dots(4.9.1)$$

ii) Coulomb's law in S.I. system :

In SI system K is chosen as $\frac{\mu_0}{4\pi}$ where

μ_0 is the permeability of free space and its value is $4\pi \times 10^{-7} \text{ Wb/A-m}$ or Hm^{-1} (henry per meter). In S.I. system Coulomb's law takes the form

$$F = \frac{\mu_0}{4\pi} \frac{m_1 \cdot m_2}{r^2} \quad \dots(4.9.2)$$

Let us, now, define a unit pole using eqn. (4.9.2)

If $m_1 = m_2 = \pm 1$ (+ for north pole and - for south pole)

and $r = 1\text{m}$,

$$F = \frac{\mu_0}{4\pi} = 10^{-7} \text{ N}$$

A unit pole in SI system is one which when placed at a distance of one meter from a similar pole of same strength in free space, will repel it with a force of 10^{-7} Newton.

Coulomb's law as expressed in eqns. (4.9.1) and (4.9.2) is valid if poles are situated in vacuum. If there is a material medium in the space between the poles, the force between them gets modified. In that case μ_0 in eqn. (4.9.2) is to be replaced by μ . μ is the characteristic of the medium and is known as the permeability of the medium.

In vector form Coulomb's law in free space in SI can be written as

$$\vec{F} = \frac{\mu_0}{4\pi} \frac{m_1 \cdot m_2}{r^2} \hat{r} \quad \dots(4.9.3)$$

The force acts along the line joining the two poles and \hat{r} is the unit vector directed from

one pole to the pole which experiences the force. Nature of pole strength for north pole is positive and south pole is negative.

4.10 Magnetic induction :

Magnetic induction at a point in a magnetic field is the force experienced by a unit north pole placed at that point. It is also known as magnetic flux density. It is denoted by \vec{B} .

If a north pole of strength m_0 experiences a force \vec{F} at any point then the magnetic induction at that point is

$$\vec{B} = \frac{\vec{F}}{m_0} \quad \dots(4.10.1)$$

or $\vec{F} = m_0 \vec{B} \quad \dots(4.10.2)$

Magnetic induction is a vector quantity. Its unit in S.I. is N/A-m or tesla (T) or Wb/m².

The c.g.s unit of magnetic induction is dyne / ab A- cm or gauss

$$1 \text{ Tesla} = 10^4 \text{ gauss}$$

4.11 Magnetic induction or magnetic field due to an isolated magnetic pole :

Consider an isolated magnetic pole of strength m at a point 'O' in free space or in air. Let P be a point at a distance r from the point 'O' (fig. 4.5). Imagine a unit north pole situated at the

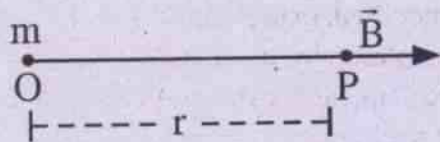

Fig. 4.5

point P. The force experienced by this unit n-pole is numerically equal to the magnetic induction due to the magnetic pole of strength m and it is obtained by substituting $m_1 = m, m_2 = 1$ in eqn. (4.9.2)

$$\therefore B_o = \frac{\mu_o}{4\pi} \cdot \frac{m}{r^2} \quad \dots(4.11.1)$$

In vector form

$$\vec{B}_o = \frac{\mu_o}{4\pi} \cdot \frac{m}{r^2} \hat{r} \quad \dots(4.11.2)$$

$$= \frac{\mu_o m}{4\pi} \cdot \frac{\vec{r}}{r^3} \quad \dots(4.11.3)$$

where \hat{r} is the unit vector along OP and

$$\vec{r} = \overrightarrow{OP}$$

If the isolated magnetic pole is situated in an infinite magnetic material medium of magnetic permeability μ , magnetic induction at any point in that medium is

$$\vec{B} = \frac{\mu}{4\pi} \cdot \frac{m}{r^2} \hat{r} \quad \dots(4.11.4)$$

Example 4.11.1 What is the magnetic induction due to a magnetic n-pole of strength 10 A-m at a distance of 10 cm in air.

Solution :

Magnetic induction in air,

$$\begin{aligned} B &= \frac{\mu_o}{4\pi} \cdot \frac{m}{r^2} \\ &= 10^{-7} \times \frac{10}{(0.1)^2} = 10^{-4} \text{ Wbm}^{-2} \end{aligned}$$

Example 4.11.2 What force does a N-pole of 4 Am experience at a point where magnetic induction is 2.5 gauss.

Solution :

Force experienced by N-pole is

$$\begin{aligned} \vec{F} &= m\vec{B} \\ &= 4 \times 25 \times 10^{-4} \text{ N} \\ &= 10^{-3} \text{ N} \end{aligned}$$

10^{-3} N parallel to \vec{B} .

4.12 Magnetic intensity or magnetising field :

Magnetic intensity (\vec{H}) at a point in a magnetic field is defined as the ratio of magnetic induction at that point to the permeability of the medium.

$$\begin{aligned}\vec{H} &= \frac{\vec{B}}{\mu} \\ &= \frac{1}{4\pi} \cdot \frac{m}{r^2} \hat{r} \quad (\text{using eqn. 4.11.4}) \\ &\dots(4.12.1)\end{aligned}$$

In free space

$$\begin{aligned}\vec{H} &= \frac{\vec{B}_0}{\mu_0} = \frac{1}{4\pi} \cdot \frac{m}{r^2} \hat{r} \quad (\text{using eqn. 4.11.2}) \\ &\dots(4.12.2)\end{aligned}$$

From eqns. 4.12.1 and 4.12.2, it is clear that magnetic intensity is independent of material of the medium.

- i) S.I. unit of H is Am^{-1}
- ii) c.g.s unit of H is Oersted

$$1\text{Am}^{-1} = 4\pi \times 10^{-3} \text{ oersted}$$

Example 4.12.1 What is the magnetic intensity due to a S-pole of strength 4π A-m at a distance of 10 cm from the pole.

Solution :

$$m = 4\pi \text{ Am}, r = 0.1 \text{ m}$$

$$\begin{aligned}\text{Magnetic intensity } H &= \frac{1}{4\pi} \cdot \frac{m}{r^2} \\ &= \frac{1}{4\pi} \cdot \frac{4\pi}{(0.1)^2} \\ &= 100\text{Am}^{-1}\end{aligned}$$

100Am^{-1} towards S-pole.

4.13 Magnetic potential :

Magnetic potential at a point in a magnetic field is the work done by an external agency in bringing a unit N-pole from infinity to that point against the magnetic field.

The magnetic potential due to a pole of strength m at a distance r from the pole in air is given by

$$V = \frac{\mu_0}{4\pi} \cdot \frac{m}{r} \quad \dots(4.13.1)$$

(The derivation of eqn. 4.13.1 is similar to that of electric potential due to a point charge) The

unit of magnetic potential in S.I. is $\text{JA}^{-1}\text{m}^{-1}$. The magnetic induction and potential are related to each other in component form as

$$B_x = -\frac{\partial v}{\partial x}, B_y = -\frac{\partial v}{\partial y} \text{ and } B_z = -\frac{\partial v}{\partial z}$$

$$\text{or } \vec{B} = -\frac{\partial v}{\partial r}$$

Example 4.13.1 Two similar poles each of strength 20 Am , are 20 cm apart in air. What is the (i) magnetic potential (ii) magnetic induction at the mid point of the line joining the two poles.

Solution :

$$m = 20 \text{ Am}, r = 0.1 \text{ m}$$

$$\text{i) } V = V_1 + V_2$$

$$= \frac{\mu_0}{4\pi} \cdot \frac{m}{r} + \frac{\mu_0}{4\pi} \cdot \frac{m}{r}$$

$$= 2 \times 10^{-7} \times \frac{20}{0.1}$$

$$= 4 \times 10^{-5} \text{ JA}^{-1}\text{m}^{-1}$$

ii) $\vec{B} = \vec{B}_1 + \vec{B}_2$

= 0 (Since \vec{B}_1 and \vec{B}_2 due to the two similar poles at their mid point equal in magnitude and opposite in direction)

Example 4.13.2 The value of magnetic induction and potential due to each pole of a horse-shoe magnet at the mid point of the line joining the two poles are B and V respectively. Find the resultant (i) induction and (ii) potential at the same point.

Solution :

i) $|\vec{B}_0| = |\vec{B}_1 + \vec{B}_2|$
 = 2B (\because magnitude and direction are same)

ii) $V = V_1 + V_2$

$$= \frac{\mu_0}{4\pi} \cdot \frac{m}{r} + \frac{\mu_0}{4\pi} \cdot \frac{-m}{r}$$

$$= 0$$

4.14 Magnetic induction or magnetic field due to a bar magnet :

a) *At a point on its axis (End-on position)*

A position on the magnetic axis of a magnet or magnetic dipole is called end-on position. Let SN be a bar magnet of magnetic length 2ℓ and pole strength m. Let P be a

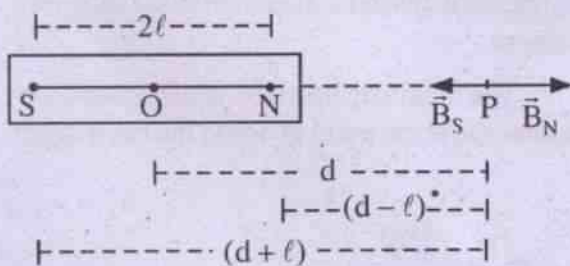

Fig. 4.6

point in the end-on position at a distance d from the mid point of the bar magnet (fig. 4.6). The magnetic field at P due to north pole is

$$\vec{B}_N = \frac{\mu_0}{4\pi} \cdot \frac{m}{(d - \ell)^2} \text{ along } \vec{NP}$$

The magnetic field at P due to south pole is

$$\vec{B}_S = \frac{\mu_0}{4\pi} \cdot \frac{m}{(d + \ell)^2} \text{ along } \vec{PN}$$

The resultant magnetic field at P due to the bar magnet is

$$\vec{B}_P = \vec{B}_N + \vec{B}_S$$

$$= \frac{\mu_0}{4\pi} \left[\frac{m}{(d - \ell)^2} + \frac{(-m)}{(d + \ell)^2} \right] \text{ along } \vec{NP}$$

$$= \frac{\mu_0 m}{4\pi} \cdot \frac{(d + \ell)^2 - (d - \ell)^2}{(d^2 - \ell^2)^2} \text{ along } \vec{NP}$$

$$= \frac{\mu_0 m}{4\pi} \cdot \frac{4d\ell}{(d^2 - \ell^2)^2} \text{ along } \vec{NP}$$

$$= \frac{\mu_0}{4\pi} \cdot \frac{2Md}{(d^2 - \ell^2)^2} \text{ along } \vec{NP}$$

$$\vec{B}_P = \frac{\mu_0}{4\pi} \cdot \frac{2\vec{M}d}{(d^2 - \ell^2)^2} \quad \dots(4.14.1)$$

Since $M = 2m\ell$ and the direction of the magnetic moment \vec{M} is parallel to \vec{NP} .

Magnetic field strength at the end-on position of the bar magnet is

$$\vec{H}_P = \frac{\vec{B}_P}{\mu_0}$$

$$= \frac{1}{4\pi} \cdot \frac{2\vec{M}d}{(d^2 - \ell^2)^2} \quad \dots(4.14.2)$$

For a short bar magnet i.e. for a magnetic dipole, $\ell \ll d$, magnetic induction at an end-on position is

$$\vec{B}_P = \frac{\mu_0}{4\pi} \cdot \frac{2\vec{M}}{d^3} \quad \dots(4.14.3)$$

b) *At a point on its equatorial line (Broad-side-on position):*

A line which is the perpendicular bisector of the bar magnet is known as an equatorial line. A position on this line is called broad-side-on position. Let Q be a point on the broad-side-on position of the bar magnet SN, at a distance d from its mid point 'O'. Let the pole strength of the magnet be m and its magnetic length be 2ℓ (fig. 4.7).

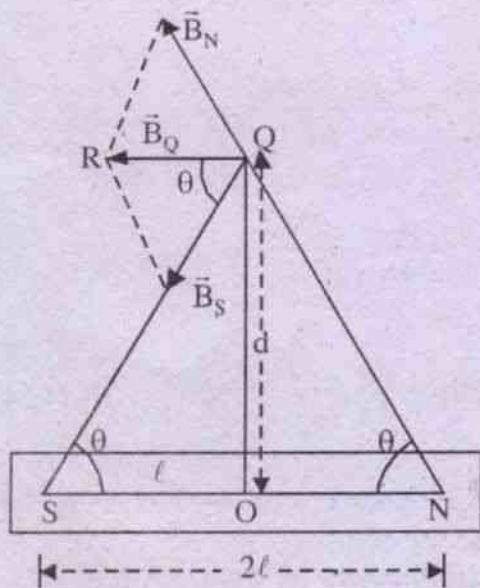

Fig. 4.7

Magnetic field at Q due to north pole of the magnet is

$$\vec{B}_N = \frac{\mu_0}{4\pi} \cdot \frac{mNQ}{(NQ)^3}$$

Magnetic field at Q due to south pole of the magnet is

$$\vec{B}_S = \frac{\mu_0}{4\pi} \cdot \frac{mQS}{(QS)^3}$$

But $NQ = QS = \sqrt{d^2 + \ell^2}$

The resultant magnetic field at the broad-side-on position Q due to the bar magnet is

$$\begin{aligned} \vec{B}_Q &= \vec{B}_N + \vec{B}_S \\ &= \frac{\mu_0}{4\pi} \cdot \frac{m}{(d^2 + \ell^2)^{3/2}} (\vec{NQ} + \vec{QS}) \end{aligned}$$

According to the triangle rule of vector addition, in the ΔNQS , $\vec{NQ} + \vec{QS} = \vec{NS}$.

The magnitude of \vec{NS} is 2ℓ and its direction is anti parallel to magnetic moment \vec{M} of the bar magnet.

$$\therefore \vec{B}_Q = \frac{\mu_0}{4\pi} \cdot \frac{m \times 2\ell}{(d^2 + \ell^2)^{3/2}} \text{ parallel to } \vec{NS}.$$

$$\vec{B}_Q = \frac{\mu_0}{4\pi} \cdot \frac{(-\vec{M})}{(d^2 + \ell^2)^{3/2}} \quad \dots(4.14.4)$$

The negative sign in eqn. (4.14.4) shows the magnetic field is antiparallel to the magnetic moment.

The magnetic intensity at the broad-side-on position at the point Q due to the bar magnet is

$$\begin{aligned} \vec{H}_Q &= \frac{\vec{B}_Q}{\mu_0} \\ &= \frac{1}{4\pi} \cdot \frac{(-\vec{M})}{(d^2 + \ell^2)^{3/2}} \quad \dots(4.14.5) \end{aligned}$$

Magnitude of the magnetic intensity is

$$H_Q = \frac{1}{4\pi} \cdot \frac{M}{(d^2 + l^2)^{3/2}} \quad \dots(4.14.6)$$

Magnetic field at broad-side-on position at Q due to a short magnet or magnetic dipole is

$$B_Q = \frac{\mu_0}{4\pi} \cdot \frac{M}{d^3} \quad \dots(4.14.7)$$

From eqns. (4.14.3) and (4.14.7) it is clear that for a magnetic dipole $B_p = 2 B_Q$ i.e. magnetic field at end on position is twice that of broad side on position provided distances of the positions are the same

c) *At any point :*

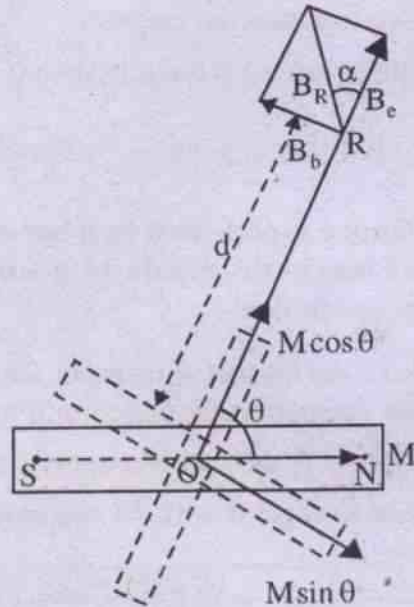

Fig 4.8

Let R be a point situated anywhere in space around the magnet SN. Let (d, θ) be its polar coordinates w.r.t. the origin 'O'. To obtain magnetic field at the point R, let us resolve magnetic moment M of the magnet into two rectangular components $M \cos \theta$ along OR and $M \sin \theta$ perpendicular to OR.

The point R is now in the end-on-position with respect to $M \cos \theta$ component and magnetic field at R due to $M \cos \theta$ component is, using eqn. (4.14.3),

$$B_e = \frac{\mu_0}{4\pi} \cdot \frac{2M \cos \theta}{d^3}$$

Again, the point R is in the broad-side-on position w.r.t $M \sin \theta$ component and magnetic field at R due to $M \sin \theta$ component is, using eqn. (4.14.7),

$$B_b = \frac{\mu_0}{4\pi} \cdot \frac{M \sin \theta}{d^3}$$

The resultant magnetic field at the point R (d, θ) is

$$\begin{aligned} B_R &= \sqrt{B_e^2 + B_b^2} \\ &= \frac{\mu_0}{4\pi} \cdot \frac{M}{d^3} \sqrt{4 \cos^2 \theta + \sin^2 \theta} \\ &= \frac{\mu_0}{4\pi} \cdot \frac{M}{d^3} \sqrt{1 + 3 \cos^2 \theta} \end{aligned} \quad \dots(4.14.8)$$

Let the resultant magnetic field B_R make an angle α with OR, then

$$\tan \alpha = \frac{B_b}{B_e} = \frac{1}{2} \tan \theta \quad \dots(4.14.9)$$

The eqns. (4.14.8) and (4.14.9) can generate back, the magnetic fields at the end on position and broad-side-on position as follows :

i) If $\theta = 0^\circ$, the point R lies on the axial line. Using eqn. (4.14.9) we have $\tan \theta = \tan \alpha = 0 \therefore \alpha = 0^\circ$ i.e. magnetic field is parallel to axial line and hence parallel to direction of magnetic moment of the magnet.

Using eqn. (4.14.8) we have

$$B_R = \frac{\mu_0}{4\pi} \cdot \frac{2M}{d^3}$$

It is same as eqn. (4.14.3)

ii) If $\theta = 90^\circ$, the point R lies on the equatorial line, using eqn. (4.14.9) we have

$$\frac{1}{2} \tan \theta = \tan \alpha = \infty$$

$$\therefore \alpha = 90^\circ$$

i.e. magnetic field is perpendicular to equatorial line. Hence it is antiparallel to the direction of magnetic moment.

Using eqn. (4.14.8), we have

$$B_R = \frac{\mu_0}{4\pi} \cdot \frac{M}{d^3}$$

It is same as eqn. (4.14.7)

Example 4.14.1 What is the magnetic field in air at a distance of 30 cm from the mid point of a magnet of magnetic length 20cm and pole strength 80 Am, on its axis.

Solution :

$$M = 2 m \ell = 80 \times 0.2 = 16 \text{ Am}^2$$

$$d = 0.3 \text{ m}, \ell = 0.1 \text{ m}$$

$$\begin{aligned} \therefore B &= \frac{\mu_0}{4\pi} \cdot \frac{2Md}{(d^2 - \ell^2)^2} \\ &= 10^{-7} \times \frac{2 \times 16 \times 0.3}{[(0.3)^2 - (0.1)^2]^2} \\ &= 1.5 \times 10^{-4} \text{ T} \end{aligned}$$

Example 4.14.2 Calculate magnetic induction in air at a point distant 50 cm from each pole of a magnet of magnetic moment 10 Am^2 .

Solution :

$$M = 10 \text{ Am}^2$$

$$\sqrt{d^2 + \ell^2} = 0.5 \text{ m}$$

$$\begin{aligned} B &= \frac{\mu_0}{4\pi} \cdot \frac{M}{(d^2 + \ell^2)^{3/2}} \\ &= 10^{-7} \times \frac{10}{(0.5)^3} = 8.0 \times 10^{-6} \text{ T} \end{aligned}$$

Example 4.14.3 The magnetic induction at an end on position of a small bar magnet is 10 gauss. What will be the magnetic induction at the broad-side-on position, keeping the distance same ?

Solution :

Due to a short bar magnet

$$B(\text{end-on}) = 2 B(\text{broad-side-on})$$

$$\therefore B(\text{broad-side-on}) = \frac{1}{2} \times 10 = 5 \text{ gauss.}$$

4.15 Torque experienced by a bar magnet or magnetic dipole in a uniform magnetic field :

Let a bar magnet of magnetic length 2ℓ and pole strength m be placed in a uniform magnetic field \vec{B} such that its magnetic moment \vec{M} makes an angle θ with the magnetic field.

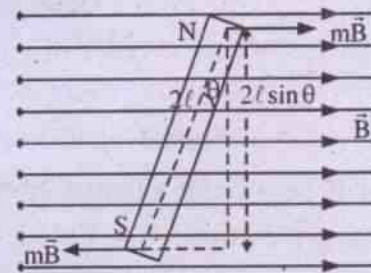

Fig. 4.9

The force, due to the magnetic field \vec{B} , acting on the N-pole is $m\vec{B}$ along the field while on

the south pole it is $m\vec{B}$ opposite to the magnetic field. These two equal and opposite forces constitute a couple. Torque (T) of the couple is

$$\begin{aligned} T &= mB \times 2\ell \sin\theta \\ &= MB \sin\theta \end{aligned} \quad \dots(4.15.1)$$

where $M = 2m\ell$ is the magnetic moment of the bar magnet. This torque tries to rotate the magnet so as to align it in the direction of magnetic field.

In vector form

$$\vec{T} = \vec{M} \times \vec{B} \quad \dots(4.15.2)$$

Example 4.15.1 What is the moment of the couple required to keep a magnet of moment 2 Am^2 at 30° to the earth's horizontal magnetic field of 0.3 gauss.

Solution :

$$\begin{aligned} M &= 2 \text{ Am}^2, \theta = 30^\circ, B = 0.3 \times 10^{-4} \text{ T} \\ T &= MB \sin\theta \\ &= 2 \times 0.3 \times 10^{-4} \times \frac{1}{2} \\ &= 0.3 \times 10^{-4} \text{ Nm} \end{aligned}$$

4.16 Work done in rotating a bar magnet in a uniform magnetic field :

We have seen in sec. 4.15 that to keep a magnet in a uniform magnetic field B in an angular position θ with the magnetic field, an external agent must apply a torque $MB \sin\theta$ in a direction opposite to the torque applied by the magnetic field. To rotate the magnet from θ to $\theta + d\theta$, the external agent must do work on the magnet and it is given by

$$\begin{aligned} dW &= T d\theta \\ &= MB \sin\theta d\theta \end{aligned}$$

Total work done by an external agent to rotate the magnet from 0° to θ is

$$\int_0^\theta dw = \int_0^\theta MB \sin\theta d\theta$$

$$\text{or } W = MB(1 - \cos\theta) \quad \dots(4.16.1)$$

Work done by an external agent to rotate the magnet from θ_1 to θ_2 w.r.t magnetic field is

$$\begin{aligned} W &= \int_{\theta_1}^{\theta_2} MB \sin\theta d\theta \\ &= MB(\cos\theta_1 - \cos\theta_2) \end{aligned} \quad \dots(4.16.2)$$

This work is stored as the potential energy of the field-magnet system. Thus

$$U(\theta_2) - U(\theta_1) = MB(\cos\theta_1 - \cos\theta_2) \quad \dots(4.16.3)$$

Potential energy U of the magnet is zero when $\theta = 90^\circ$. Let θ_2 be 90° and $\theta_1 = \theta$. Substituting in eqn. (4.16.3), we have

$$-U(\theta) = MB \cos\theta$$

$$\text{or } U(\theta) = -MB \cos\theta = -\vec{M} \cdot \vec{B} \quad \dots(4.16.4)$$

Thus potential energy of a magnet in a uniform magnetic field is $U(\theta) = -\vec{M} \cdot \vec{B}$.

When the magnetic moment of the magnet is parallel to magnetic field, it is in equilibrium and it has minimum potential energy

$$U = -MB \quad (\because \theta = 0^\circ)$$

Example 4.16.1 A magnet is parallel to a uniform magnetic field. If it is rotated through 60° , the work done is $8 \times 10^{-5} \text{ J}$. How much work will be done in rotating it through another 30° ?

Solution :

$$W = 8 \times 10^{-5} \text{ J}, \theta_1 = 60^\circ,$$

$$\theta_2 = 60^\circ + 30^\circ = 90^\circ$$

$$W = MB(1 - \cos \theta)$$

$$8 \times 10^{-5} = MB(1 - \cos 60^\circ)$$

$$\therefore MB = 16 \times 10^{-8} \text{ J}$$

$$\begin{aligned} W' &= MB(\cos \theta_1 - \cos \theta_2) \\ &= MB(\cos 60^\circ - \cos 90^\circ) \\ &= \frac{1}{2} MB = 8 \times 10^{-8} \text{ J} \end{aligned}$$

4.17 Terrestrial magnetism :

About 1600 A.D. William Gilbert gave the first satisfactory evidence for the existence of terrestrial magnetism i.e. magnetism of the earth. The observed magnetism of the earth can roughly be portrayed as if it were a huge bar magnet within the earth, with its axis displaced about 17° from earth's axis and considerably shorter than earth's diameter (fig. 4.10). Two magnetic poles, each of strength about $8.0 \times 10^{22} \text{ Am}^2$ are located in northern Canada and in Antarctica, both at considerable distance from geographical poles.

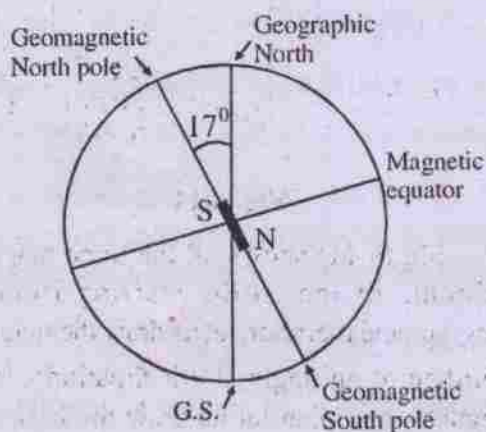

Fig. 4.10

A compass needle aligns itself in a north-south position with its north pole pointing towards north. This pole indicates the presence of earth's magnetic south pole in northern hemisphere and magnetic north pole in southern hemisphere.

On his first voyage to America, Columbus observed that a compass needle does not point directly north and that it does not everywhere point in the same direction. This deviation of the reading of the compass needle from true north is called magnetic declination.

The actual direction of magnetic field of the earth at most places is not horizontal. If a magnetic needle is mounted on a horizontal axis through its centre of gravity, its north pole will dip in northern hemisphere while south pole will dip in southern hemisphere. Such a needle is known as dip needle which determines direction of earth's magnetic field at a place.

The theory of earth's magnetic field is not yet well understood. It may be due to circulating electric currents induced in the molten liquid and other conducting material inside the earth.

The concept of a huge magnet at the centre of earth is purely hypothetical, only to explain the magnetic field of the earth. As the interior of the earth is at a very high temperature, no magnet can exist without meeting.

4.18 Some terms connected with geomagnetism :

i) Geomagnetic axis :

It is the axis of the geomagnet. It cuts earth's surface at two points, viz., geomagnetic north pole (near the geographic north pole) and geomagnetic south pole (near the geographic south pole)

ii) Geographical axis :

The axis about which the earth rotates is called the geographical axis or polar axis. It is also the line joining geographic north and south poles of the earth.

iii) Magnetic axis :

A line joining the north and south poles of a freely suspended magnet on the surface of the earth is called magnetic axis.

iv) **Magnetic equator :**

The plane perpendicular to the magnetic axis of the earth and passing through all those points, where a magnetic needle aligns parallel to earth's surface i.e. becomes horizontal, intersects the earth's spherical surface into a circle. This circle is called magnetic equator.

v) **Magnetic meridian :**

A vertical plane passing through magnetic axis of a freely suspended magnet is called magnetic meridian.

vi) **Geographic meridian :**

A vertical plane passing through geographic axis is called the geographic meridian.

4.19 Magnetic elements of earth :

The earth's magnetic field at a point on its surface is completely specified by three quantities : (a) declination or variation (b) inclination or dip and (c) horizontal component of earth's magnetic field. These are known as the elements of earth's magnetic field.

a) **Declination or variation :**

The angle made by the magnetic meridian at a point with the geographical meridian is called the declination at that point.

Magnetic needle stays in equilibrium in magnetic meridian. Hence the north direction shown by the needle makes an angle equal to the declination with the true north and navigators have to take care of it. Declination at a place is

expressed as θ° E or θ° W. For example, declination at Delhi is 2° E. It means that north pole of a horizontal compass needle will point 2° E to the geographical north-south direction.

b) **Inclination or dip (δ)**

The angle made by earth's (resultant) magnetic field with the horizontal direction in the magnetic meridian at a place, is called the inclination or dip at that place.

In northern hemisphere, south polarity of earth magnet exists and hence, north pole of a magnetic needle dips (goes down). Angle of dip at the magnetic poles is 90° and at the magnetic equator it is 0° . Thus angle of dip varies from 0° to 90° from place to place on the surface of the earth.

Thus the knowledge of declination and inclination completely specifies the direction of earth's magnetic field.

c) **Horizontal component of earth's magnetic field (B_H) :**

Horizontal component of earth's magnetic field is the component of earth's magnetic field in the horizontal direction in the magnetic meridian.

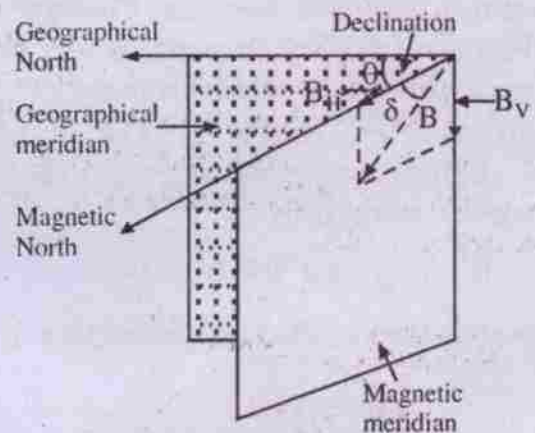

Fig. 4.11

Fig (4.11) shows all the three magnetic elements of the earth. Starting from the geographical meridian let us draw the magnetic meridian at an angle θ (declination). In the magnetic meridian let us draw the horizontal direction specifying magnetic north. The magnetic field is at an angle δ (dip) from this direction. Total or resultant magnetic field (B) of the earth is related to its horizontal component (B_H) as

$$B_H = B \cos \delta$$

$$\text{or } B = B_H / \cos \delta$$

Thus, from the knowledge of the three elements, both magnitude and direction of the earth's magnetic field can be obtained.

Vertical component of earth's magnetic field

$$B_V = B \sin \delta$$

$$\tan \theta = \frac{B_V}{B_H} \quad \dots(4.19.1)$$

$$\text{or } \delta = \tan^{-1} \frac{B_V}{B_H}$$

$$B = \sqrt{B_H^2 + B_V^2}$$

4.20 Apparent dip :

It is the angle of dip in a vertical plane other than magnetic meridian. Consider a vertical plane making an angle α with the magnetic meridian. Horizontal component (B'_H) and vertical component (B'_V) of earth's magnetic field in this plane are related to those in magnetic meridian by

$$B'_H = B_H \cos \alpha \text{ and } B'_V = B_V$$

If δ' is the apparent dip in that plane, then

$$\tan \delta' = \frac{B'_V}{B'_H} = \frac{B_V}{B_H \cos \alpha} = \frac{\tan \delta}{\cos \alpha}$$

(using eqn. 4.19.1)
... (4.20.1)

i) If $\alpha = 0^\circ$, $\delta' = \delta$

ii) If $\alpha = 90^\circ$, $\delta' = 90^\circ$ i.e. if a dip needle is rotated through 90° from magnetic meridian, magnetic needle will point vertically downward.

Consider two mutually perpendicular vertical planes each one on either side of magnetic meridian making angles α_1 and α_2 respectively with it. Let δ_1 and δ_2 be the apparent dips in these two planes respectively. Using eqn. (4.20.1) we have

$$\tan \delta_1 = \frac{\tan \delta}{\cos \alpha_1}$$

$$\text{or } \cot \delta_1 = \cos \alpha_1 \cdot \cot \delta$$

$$\text{or } \cot^2 \delta_1 = \cos^2 \alpha_1 \cdot \cot^2 \delta$$

Similarly

$$\cot^2 \delta_2 = \cos^2 \alpha_2 \cdot \cot^2 \delta$$

$$= \sin^2 \alpha \cdot \cot^2 \delta$$

$$(\because \alpha_1 + \alpha_2 = 90^\circ)$$

$$\therefore \cot^2 \delta_1 + \cot^2 \delta_2 = (\cos^2 \alpha_1 + \sin^2 \alpha) \cot^2 \delta$$

$$\text{or } \cot^2 \delta_1 + \cot^2 \delta_2 = \cot^2 \delta \quad \dots(4.20.2)$$

Thus, knowing apparent dips in two mutually perpendicular vertical planes, using eqn. (4.20.2), true dip at a place can be determined.

Example 4.19.1 What is the dip at a place where horizontal component of earth's magnetic field is equal to the vertical component ?

Solution :

$$B_H = B \cos \delta \text{ and } B_V = B \sin \delta$$

$$\text{But } B_H = B_V$$

$$\therefore B \cos \delta = B \sin \delta$$

$$\tan \delta = 1$$

$$\therefore \delta = 45^\circ$$

Example 4.19.2 The earth's magnetic field is $3.6 \times 10^{-5} \text{ T}$ at a place where the angle of dip is 60° . What is the horizontal component of earth's magnetic field ?

Solution :

$$\text{Horizontal component } B_H = B \cos \delta$$

$$= 3.6 \times 10^{-5} \times \frac{1}{2}$$

$$= 1.8 \times 10^{-5} \text{ T}$$

Example 4.19.3 The earth's total magnetic field is same at two places but dips are 30° and 60° respectively. Compare the earth's horizontal fields at the two places.

Solution :

$$B_H = B \cos \delta$$

$$B'_H = B \cos \delta'$$

$$\frac{B_H}{B'_H} = \frac{\cos \delta}{\cos \delta'} = \frac{\sqrt{3}}{2 \times \frac{1}{2}} = \sqrt{3} : 1$$

Example 4.20.1 The apparent dip in a plane making an angle of 60° with magnetic meridian is $\tan^{-1} 2$. Find the value of true dip.

Solution :

$$\alpha = 60^\circ, \delta' = \tan^{-1} 2$$

$$\tan \delta' = \frac{\tan \delta}{\cos \alpha}$$

$$\text{or } \tan \delta = 2 \times \frac{1}{2} = 1$$

$$\therefore \text{ True Dip } \delta = 45^\circ$$

Example 4.20.2 The apparent dips in two mutually perpendicular planes are 38° and 90° . Find the value of true dip.

Solution :

$$\delta_1 = 38^\circ, \delta_2 = 90^\circ$$

$$\cot^2 \delta = \cot^2 \delta_1 + \cot^2 \delta_2$$

$$= \cot^2 38^\circ + 0$$

$$\therefore \delta = \delta_1 = 38^\circ$$

4.21 Neutral point :

Earth has its own magnetic field everywhere. If a bar magnet is placed on the

surface of the earth, at some points, horizontal component of magnetic field of the earth and the magnetic field of the bar magnet become equal and opposite so that net magnetic field becomes zero. Such points are called neutral points. A compass needle placed at the neutral point will not show any preferred direction.

Neutral point is a point in the region around a magnet where its magnetic field is neutralized by the horizontal component of earth's magnetic field.

i) *Neutral points observed (on the surface of the earth) due to a bar magnet placed in the magnetic meridian with its*

a) *North pole pointing towards north*

In this case two neutral points are observed, each one on either side of the magnet on the perpendicular bisector of the magnetic axis of the magnet. These points are broad-side-on positions of the bar magnet. The magnetic field of the magnet at these points are given by the eqn. (4.14.4) as

$$B = B_H \frac{\mu_0}{4\pi} \cdot \frac{M}{(d^2 + \ell^2)^{3/2}} \quad \dots(4.21.1)$$

At neutral points, $B = B_H$ where B_H is the horizontal component of magnetic field of the earth. It is worth mentioning here that in the case of a freely suspended bar magnet many neutral points are observed in its equatorial plane.

b) *North pole pointing towards south*

In this case two neutral points are obtained, each one on either side of the magnet on its magnetic axis. At these points magnetic field of the bar magnet is obtained by considering them on end-on positions and using eqn. (4.14.1) we have

$$B = B_H = \frac{\mu_0}{4\pi} \cdot \frac{2Md}{(d^2 - \ell^2)^2} \quad \dots(4.21.2)$$

Thus with the help of a bar magnet, knowing its magnetic moment M , measuring

experimentally d and l , using the eqn. 4.21.1 or 4.21.2 we can determine horizontal component of magnetic field of the earth at a place.

Example 4.21.1 A short magnet produces a neutral point at broad-side-on position at 20 cm from the magnet. If the earth's horizontal field is $4 \times 10^{-5} \text{ wb/m}^2$, find the magnetic moment of the magnet.

Solution :

$$\text{At neutral point } B = B_H = \frac{\mu_0}{4\pi} \times \frac{M}{d^3}$$

$$\begin{aligned} \therefore M &= \frac{4\pi}{\mu_0} B_H d^3 \\ &= 10^7 \times 4 \times 10^{-5} \times (0.2)^3 \\ &= 3.2 \text{ Am}^2 \end{aligned}$$

ii) **Neutral point due to a single pole :**

The single pole is realised by a long magnet placed vertically on the surface of the earth. The effect of upper pole is neglected as the magnet is long. Only one neutral point is obtained due to single pole.

a) When north pole is on the horizontal plane, a neutral point is obtained to the south of the pole;

$$B = B_H = \frac{\mu_0}{4\pi} \cdot \frac{m}{d^2}$$

b) When south pole is on the horizontal plane a neutral point is obtained to the north of the pole;

$$B = B_H = \frac{\mu_0}{4\pi} \cdot \frac{m}{d^2}$$

Example 4.21.2 A very long magnet is placed vertically with one pole on the table. A neutral point is obtained at 5 cm from the pole. If the

pole strength is 0.9 Am, find horizontal component of earth's field at that place.

Solution :

At neutral point,

$$\begin{aligned} B &= B_H = \frac{\mu_0}{4\pi} \cdot \frac{m}{d^2} \\ &= 10^{-7} \times \frac{0.9}{(0.05)^2} \\ &= 0.36 \times 10^{-4} \text{ T} \end{aligned}$$

4.22 Magnetic properties of materials :

Magnetic moment of an atom is mostly due to spin and orbital motion of its electrons. A pair of electrons in an atom will have a tendency to cancel their magnetic moments e.g. the magnetic moments of the two electrons of helium atom cancel each other. Thus in a number of materials, resultant magnetic moment of their atoms is zero. But in some cases, the magnetic moment of an atom is not zero. Such an atom behaves as a magnetic dipole having a permanent magnetic moment. Let us concentrate on materials made of such atoms.

In an unmagnetised specimen of a material, their atomic dipoles are randomly oriented and net magnetic moment of the specimen is zero. However, when the specimen is kept in an external magnetic field, torques act on the atomic dipoles and these torques try to align them parallel to the field. The alignment is partial due to thermal motion of atoms which tries to dealign the atomic magnetic moments. The degree of alignment increases with increase in strength of magnetic field and with decrease of temperature.

4.23 Intensity of magnetization (I)

Intensity of magnetization is defined as the magnetic moment developed per unit volume of the specimen, when it is subjected to a uniform magnetic field. Thus

$$I = \frac{M}{V} \quad \dots(4.23.1)$$

I is a vector quantity. Its direction is in the direction of the magnetic moment. Its unit is Am^{-1} .

Consider a bar magnet of pole strength m , magnetic length 2ℓ and area of cross section 'a'.

$$I = \frac{M}{V} = \frac{2m\ell}{a \cdot 2\ell} = \frac{m}{a} \quad \dots(4.23.2)$$

Thus, for a bar magnet, the intensity of magnetization may be defined as the pole strength per unit area, area being perpendicular to the direction of magnetization.

4.24 Magnetic intensity or Magnetizing field intensity \vec{H} .

When a magnetic field is applied to a material, the material gets magnetized. The degree to which a magnetic field can magnetize a material is expressed by a vector \vec{H} , called as magnetic intensity. Its magnitude is equal to the number of ampere turns flowing round the unit length of a solenoid required to produce that magnetic field. Thus, the magnetic intensity due to a current carrying solenoid of n turns per meter is

$$H = ni \text{ ampere turns/meter} \quad \dots(4.14.1)$$

where i is the current in the coil.

Magnetic induction inside a long solenoid without any magnetic material in it is

$$B_0 = \mu_0 ni = \mu_0 H \quad \dots(4.24.2)$$

$$\text{or } \vec{H} = \frac{\vec{B}_0}{\mu_0} \quad \dots(4.24.3)$$

Thus, the magnetic intensity due to a current element $i d\vec{\ell}$ is, from Biot-savart law,

$$d\vec{H} = \frac{1}{4\pi} \frac{id\vec{\ell} \times \hat{r}}{r^2} \quad \dots(4.24.4)$$

The magnetic intensity due to a magnetic pole of pole strength m at a distance r from it is (using eqn. 4.11.1)

$$H = \frac{m}{4\pi r^2} \quad \dots(4.24.5)$$

We note here that \vec{H} does not depend on the material of the medium. The magnetic intensity in a material is determined by the external sources only, even if the material is magnetised.

4.25 Magnetic Induction or magnetic flux density \vec{B} :

When a magnetizing field \vec{H} is applied to a magnetic material, it gets magnetized. The net magnetic induction \vec{B} in the material due to the magnetizing field \vec{H} is now regarded as the sum of the magnetic induction \vec{B}_0 in vacuum and the magnetic induction \vec{B}_m due to induced magnetism of the material. Thus

$$\vec{B} = \vec{B}_0 + \vec{B}_m \quad \dots(4.25.1)$$

Intensity of magnetization \vec{I} is related to \vec{B}_m by

$$\vec{B}_m = \mu_0 \vec{I}$$

$$\begin{aligned} \therefore \vec{B} &= \mu_0 \vec{H} + \mu_0 \vec{I} \\ &= \mu_0 (\vec{H} + \vec{I}) \end{aligned} \quad \dots(4.25.2)$$

We note here that H and I have same unit Am^{-1} .

Example 4.25.1 A tightly wound, long solenoid of 25 turns/cm carries a current of 2.0 A. Find the magnetic intensity and the magnetic field at the centre of the solenoid. What will be their values if an iron core is inserted in the solenoid, given the intensity of magnetization in the iron core is $4.0 \times 10^6 \text{ Am}^{-1}$.

Solution :

The magnetic intensity H at the centre of the solenoid is

$$\begin{aligned} H &= n i \\ &= 25 \times 10^2 \times 2 = 5.0 \times 10^3 \text{ Am}^{-1} \end{aligned}$$

The magnetic field

$$\begin{aligned} B &= \mu_0 H \\ &= 4\pi \times 10^{-7} \times 5.0 \\ &= 6.25 \text{ mT} \end{aligned}$$

When the iron core is inserted, the value of H remains the same as $5.0 \times 10^3 \text{ Am}^{-1}$ whereas B becomes

$$\begin{aligned} B &= \mu_0(H+I) \\ &= 4\pi \times 10^{-7} (5 \times 10^3 + 4 \times 10^6) \\ &= 5.035 \text{ T.} \end{aligned}$$

4.26 Magnetic susceptibility (χ) :

It is a measure of the ease with which a material can be magnetized by a magnetising field intensity H . It is defined as the ratio of intensity of magnetization I produced in the given material to the magnetizing field intensity H .

$$\chi = \frac{I}{H} \quad \dots(4.26.1)$$

As I and H have same units, χ is unitless i.e. dimensionless quantity. In vacuum, $I = 0$ and hence $\chi = 0$. For paramagnetic materials χ is positive as I is positive. For diamagnetic materials χ is negative as I is negative.

4.27 Permeability :

Magnetic induction in a magnetic material due to a magnetizing field H is given by eqn. (4.25.2) as

$$B = \mu_0(H+I)$$

$$= \mu_0(H + \chi H) \quad \text{(using eqn. 4.26.1)}$$

$$\begin{aligned} &= \mu_0(1 + \chi)H \\ &= \mu H \quad \dots(4.27.1) \end{aligned}$$

$$\text{where } \mu = \mu_0(1 + \chi) \quad \dots(4.27.2)$$

μ is a constant called permeability of the material. For vacuum, $\chi = 0$, $\mu = \mu_0$ is the permeability of vacuum, $\mu_0 = 4\pi \times 10^{-7} \text{ Wb A}^{-1} \text{ m}^{-1}$ or Hm^{-1}

$$\text{Again, } \mu = \frac{B}{H} \quad \dots(4.27.3)$$

The permeability of a material is defined as the ratio of magnetic induction in the material to the magnetising field.

$$\begin{aligned} \text{The constant } \mu_r &= \frac{\mu}{\mu_0} = \frac{B}{B_0} = 1 + \chi \\ &\dots(4.27.4) \end{aligned}$$

is called relative permeability of the material.

Relative permeability of a material is the ratio of the permeability of the material to the permeability of vacuum.

Relative permeability is a pure number. Its value for air and many other "nonmagnetic" substances is practically equal to unity.

Example 4.27.1 An iron rod of cross-sectional area $5 \times 10^{-4} \text{ m}^2$ is placed parallel to a magnetising field of $2 \times 10^3 \text{ Am}^{-1}$. The magnetic flux through the rod is $4 \times 10^{-4} \text{ wb}$. Calculate (i) the permeability (ii) the relative permeability and the susceptibility of the rod.

Solution:

$$\text{Magnetic flux } \phi = 4 \times 10^{-4} \text{ wb}$$

$$\text{Magnetising field } H = 2 \times 10^3 \text{ Am}^{-1}$$

$$\text{Area of cross-section } A = 5 \times 10^{-4} \text{ m}^2$$

$$\begin{aligned} \text{Permeability } \mu &= \frac{B}{H} = \frac{\phi}{AH} \\ &= \frac{4 \times 10^{-4}}{5 \times 10^{-4} \times 2 \times 10^3} \\ &= 4.0 \times 10^{-4} \text{ Hm}^{-1} \end{aligned}$$

$$\text{Relative permeability } \mu_r = \frac{\mu}{\mu_0} = \frac{4.0 \times 10^{-4}}{4 \times 10^{-7}} = 318$$

$$\text{Susceptibility } \chi = \mu_r - 1 = 317$$

4.28 Curie's law :

Curie's law states that the susceptibility of an unsaturated paramagnetic substance is inversely proportional to its absolute temperature.

$$\begin{aligned} \chi &\propto \frac{1}{T} \\ \chi &= \frac{C}{T} \quad \dots(4.28.1) \end{aligned}$$

where C is known as the Curie constant.

When a ferromagnetic material is heated, it becomes a paramagnetic at a certain temperature. This temperature is called Curie point or Curie temperature. Above this temperature, the susceptibility varies as

$$\chi = \frac{C'}{T - T_c} \quad \dots(4.28.2)$$

Where C' is a constant and T_c is the curie point. This law (eqn. 4.28.2) is known as the Curie-Weiss law for ferromagnetics. Curie point for Iron is 1043 K, for Cobalt is 1394 K and for Nickel is 631 K.

4.29 Classification of Magnetic Materials :

Faraday observed that all substances have certain magnetic properties. Historically, the

classification of magnetic materials was done in terms of the response of substances to magnetic fields. Experimental study, by putting various substances one by one in the region of intense magnetic field suggests that there are at least three kinds of magnetic materials viz., (i) Diamagnetic substances, (ii) Paramagnetic substances and (iii) Ferromagnetic substances.

4.30 Diamagnetic substances :

The substances, which when placed in a strong magnetic field, acquire a weak magnetism in a direction opposite to that of applied magnetic field, are known as diamagnetic substances. Hence diamagnetic substances are weakly repelled by strong magnets. Bismuth, sodium chloride, quartz, copper, zinc, silver, gold, diamond, mercury, nitrogen, water etc. are some of the examples of diamagnetic substances.

In 1905 P. Langevin explained the origin of diamagnetism. Consider an electron of charge e moving in a circular orbit of radius r with a speed v and angular velocity ω . The circulating electron produces a current $i = ne$ where n is the frequency of revolution of the electron. The magnetic moment M produced by this current is equal to the current times the area of the orbit

$$M = iA = ne \times \pi r^2 = \frac{\omega e}{2\pi} \times \pi r^2 = \frac{ve}{2\pi r} \times \pi r^2$$

$$\text{or, } M = \pi r^2 ne = \frac{1}{2} \omega r^2 e = \frac{1}{2} ver \quad \dots(4.30.1)$$

Diamagnetism is observed in those substances in which atoms or molecules have even number of electrons which form pairs such that the orbital and spin motions of each electron are equal and opposite to those of the other so that the net magnetic moment produced by each pair of electrons is zero.

When an external magnetic field is applied to a diamagnetic substance, one electron of each pair gets slowed down while the other

electron gets accelerated. Consequently, the magnetic moment in the former case decreases while in the latter it increases. Hence every atom gets a net magnetic dipole moment in the presence of external magnetic field but in a direction opposite to it. This phenomenon of acquiring a magnetism in a direction opposite to the direction of magnetizing field is called diamagnetism and such materials are called diamagnetic materials.

Properties of diamagnetic substances :

- a) Diamagnetic substances are weakly repelled by strong magnets. They move towards the region of decreasing magnetic field.
- b) A freely suspended diamagnetic bar in a uniform magnetic field comes to rest at

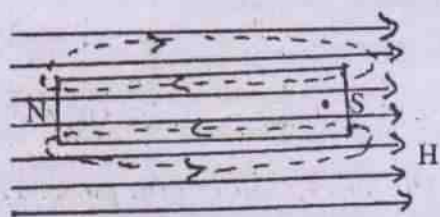

(a) Diamagnetic substance in a magnetic field



(b) Paramagnetic substance in a magnetic field



$\chi > 1$

(c) Ferromagnetic substance in a magnetic field

right angles to the direction of the magnetic field.

- c) Intensity of magnetisation I is directly proportional to magnetic intensity H

$$I = \chi H$$

However, the susceptibility χ is a small negative quantity ($\chi < 0$) so that a diamagnetic substance gets magnetised in the opposite direction of magnetising field H.

- d) Since $B = \mu_0(1 + \chi)H$ and $\chi < 0$, it follows that $B < \mu_0H$. Magnetic field inside the material is less than that outside it (fig. 4.12 a).

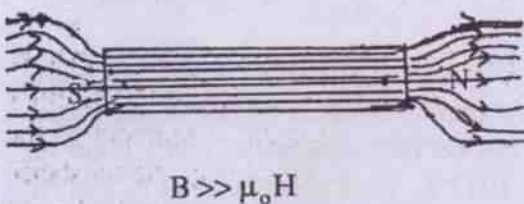
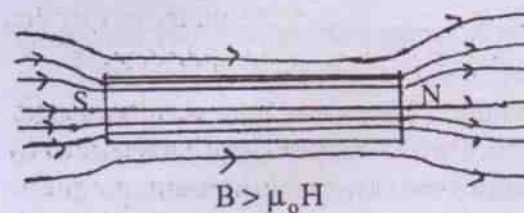
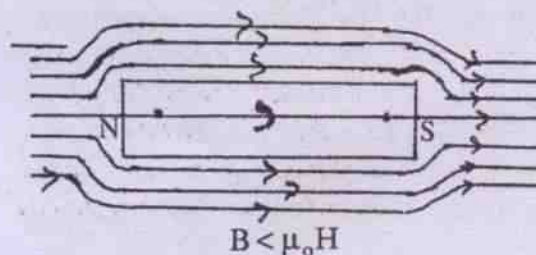

Fig. 4.12

- e) Since $\mu_r = (1 + \chi)$ and $\chi < 0$, it follows that relative permeability of a diamagnetic substances is less than unity.
- f) Unlike paramagnetic substances, the susceptibility χ of diamagnetic substances is independent of temperature. This incidently suggests that basic causes of dia and paramagnetic behaviour are not opposite of each other.
- g) Diamagnetism is a universal effect i.e., it is a common property of all substances. The reason why some substances are paramagnetic or ferromagnetic is that diamagnetism is a very weak effect and it easily gets masked in case of substances that have either paramagnetic or ferromagnetic behaviour.

4.31 Paramagnetic substances :

The substances, which when placed in a strong magnetic field, acquire weak magnetism in the same direction as the external magnetic field are known as paramagnetic substances. Hence these substances are weakly attracted by a strong magnet.

Aluminium, platinum, sodium, manganese, magnesium, chromium, oxygen etc. are examples of paramagnetic substances.

Langevin also explained paramagnetism. Paramagnetic substances are characterized by molecules having a permanent magnetic moment similar to the permanent electric dipole moment possessed by the atoms of a polar dielectric.

In an unmagnetised paramagnetic sample, molecular magnetic dipoles are randomly oriented so that net magnetic moment of the sample is zero. When a paramagnetic substance is subjected to an external magnetic field, each molecular dipole experiences a torque tending to align it in the direction of magnetic field. This tendency for alignment is opposed by the random molecular movements caused by

thermal agitation. At any given temperature, therefore, a state of equilibrium is set up and this determines the resultant induced magnetic moment in the direction of external magnetic field. Thus intensity of magnetization of a paramagnetic substance increases with increase in strength of the external magnetic field and with decrease in temperature until its saturation occurs. Thus, for a paramagnetic substance, well before its saturation occurs

$$I \propto H$$

$$\propto \frac{1}{T}$$

$$\text{or } I = \frac{CH}{T} \quad \text{where } C \text{ is a constant}$$

$$\frac{I}{H} = \frac{C}{T}$$

$$\text{or } \chi \propto \frac{1}{T} \quad \left(\text{where } \chi = \frac{I}{H} \right)$$

The susceptibility of a paramagnetic substance is inversely proportional to its absolute temperature. This is known as Curie's law.

Properties of paramagnetic substances :

- Paramagnetic substances are weakly attracted by strong magnets. They move towards the region of increasing magnetic field strength.
- A freely suspended paramagnetic bar in a uniform magnetic field, comes to rest in the direction of magnetic field.
- Intensity of magnetisation I varies linealy with H :

$$I = \chi H$$

The constant of proportionality χ is known as susceptibility of the material and it is a small positive quantity. Thus a

- paramagnetic substance gets magnetized in the direction of magnetising field H .
- d) Since $B = \mu_0(1 + \chi)H$ and $\chi > 0$, it follows that $B > \mu_0 H$. Magnetic field inside the material is more than that outside it (fig. 14.12.b).
- e) Since $\mu_r = 1 + \chi$ and $\chi > 0$, it follows that relative permeability μ_r of a paramagnetic substance is greater than unity.
- f) The magnetic susceptibility of a paramagnetic substance varies inversely as its absolute temperature T ,

$$\chi = \frac{C}{T}$$

This relation is known as Curie's law for paramagnetism.

- g) Paramagnetism occurs in those substances in which molecules have permanent magnetic dipole moments. Hence it is not a universal phenomenon.

4.32 Ferromagnetic substances :

The substances which are strongly magnetised by a relatively weak magnetic field and acquire magnetism in the direction of the external magnetic field are known as ferromagnetic substances. Hence these substances are strongly attracted by magnets.

Fe, Co, Ni, Gd and Dy etc. are examples of ferromagnetic substances.

Iron vapour and iron ions in a solution exhibit only paramagnetism whereas solid iron is a ferromagnetic. The above fact suggests that ferromagnetism is not the property of individual atoms but of the crystals that make up a ferromagnetic material.

Ferromagnetism occurs in those substances in which atoms possess permanent dipole magnetic moments as in paramagnetism

as well as a quantum interaction called exchange coupling among the dipole moments of neighbouring atoms. Due to exchange coupling, the dipole moments of neighbouring atoms are strongly coupled to form microcrystal regions called domains. In each domain there is a perfect alignment of atomic dipole moments. Each domain has about 10^{20} atoms. A ferromagnetic substance has a large number of domains which have their magnetic moments (represented by arrows in Fig. 4.13) randomly oriented in an unmagnetized sample.

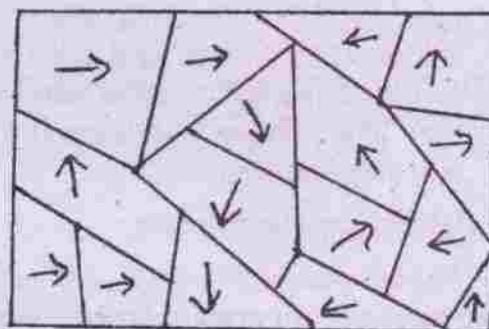

Fig. 4.13

When an external magnetizing field is applied, the domains which are nearly parallel in orientation with this field increase in size at the expense of other domains. As the field grows stronger, rotation of magnetic moment within domains takes place, and saturation is reached when all domains are aligned in the direction of magnetic field. If a ferromagnetic substance is heated, above a certain temperature, called as Curie point the exchange coupling disappears, domain structure ceases and the substance becomes paramagnetic.

Properties of ferromagnetic materials :

- Ferromagnetic substances are strongly attracted by magnets. They move towards the region of increasing magnetic field strength.
- A freely suspended ferromagnetic bar in a uniform magnetic field comes to rest in the direction of the magnetic field.

- c) Unlike dia or paramagnetics, the intensity of magnetisation I of a ferromagnetic substance is not proportional to H . Not only that, I is also not a single valued function of H i.e., there is no unique value of I for a given H .
- d) In a sense, a ferromagnetic is a stronger paramagnetic substance. In fact there is a magnetic transformation temperature for each ferromagnetic substance; below this temperature the material behaves like a ferromagnetic while above it, it behaves like a paramagnetic. This temperature (T_c) is the Curie temperature of a given ferromagnetic. Above this temperature, the susceptibility will vary as

$$\chi = \frac{C'}{T - T_c}$$

where C' is a constant and T and T_c are absolute temperatures. This law is known as the Curie-Weiss law.

- e) Since $B = \mu_0(1 + \chi)H$ and $\chi \gg 0$, it follows that $B \gg \mu_0 H$ i.e., magnetic field inside the material is very much greater than that outside it. (Fig. 4.12 c)
- f) Relative permeability $\mu_r \gg 1$ for a ferromagnetic substance.
- g) A ferromagnetic substance exhibits an effect known as hysteresis. However, some materials are soft ferromagnets while others are hard ferromagnets. They are distinguished on the basis of areas of their hysteresis loops. Soft ferromagnets have small loop areas, while hard ferromagnets have comparatively larger hysteresis loop area. One can make permanent magnets from hard ferromagnetic substances only which have large retentivity and large coercive force as discussed in detail below.

4.33 Hysteresis :

The magnetisation of a ferromagnetic material is not a definite function of H but is found to depend upon the previous magnetic, internal and mechanical treatment of the specimen. This behaviour of ferromagnetics is known as hysteresis.

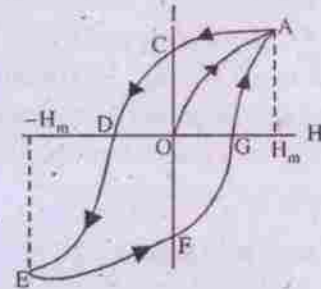

Fig. 4.14

Fig. (4.14) shows a typical magnetization curve when H is increased in steps from zero. To start with a ferromagnetic sample which has no initial magnetization and $H = 0$, then $I = 0$. This corresponds to the point O . As H increases, magnetization increases. Soon the magnetization acquires a saturation value (point A) corresponding to an applied field H_m upto which the magnetization varies along the path OA . Now suppose, H is gradually decreased. The magnetization decreases but the path OA is not retraced. As H becomes zero, $I \neq 0$ i.e., some magnetization is left in the sample. The domains, that were aligned at the time of increasing H , are not completely at random as the magnetic intensity H is reduced to zero. Thus, the value of I lags behind H . *Lagging of I behind H is known as hysteresis.* The remaining value of I at the point C is called the retentivity of the material.

Now let the field be reversed and increased in the reverse direction in steps. The value of H needed to make $I = 0$ is called the coercive force. In fig. (4.14), the coercive force is represented by the magnitude of H corresponding to OD . On increasing the field in the reverse direction, the material gets

magnetized in the opposite direction. The magnetisation, I follows the path DE as the magnetic intensity becomes $-H_m$. As H is reduced to zero from $-H_m$, magnetization I follows the path EF . Finally if H is increased in the original direction, the point A is reached via FGA . If we change H cyclically from H_m to $-H_m$ to H_m the curve $ACDEFGA$ is retraced. The curve $ACDEFGA$ is called the hysteresis loop. The area of the hysteresis loop is proportional to heat energy developed per unit volume of the material as it undergoes through one complete hysteresis cycle.

4.34 Soft iron and steel :

Steel has larger retentivity, coercive force and area of hysteresis loop than those of soft iron. Soft iron is easily magnetised by a magnetising field but only a small magnetisation is retained when the field is removed. Also, loss of energy, as the material is taken through periodic variations in magnetising field, is small. Materials like soft iron are suitable for making electromagnets and cores inside current carrying coils to increase the magnetic field. In transformers, moving-coil galvanometers etc., soft iron core is used in the coils.

Materials like steel are suitable for making permanent magnets because once these materials are magnetised, a large magnetisation is retained (as retentivity is large) when the magnetizing field is removed. Moreover, the magnetisation is not easily destroyed even when the material is exposed to stray reverse fields as its coercive force is also large.

4.35 Tangent law :

The tangent law states that if a freely suspended magnet is subjected to two uniform magnetic fields, say B and B_e , at right angles to each other, it comes to rest making an angle θ with the field B_e where

$$B = B_e \tan \theta \quad \dots(4.35.1)$$

To establish this law, let us consider the fig. (4.15) in which the two uniform magnetic fields B_e and B are at right angles to each other. The magnet NS is in equilibrium making an angle θ with B_e and it is subjected to two couples as shown in the fig. (4.15)

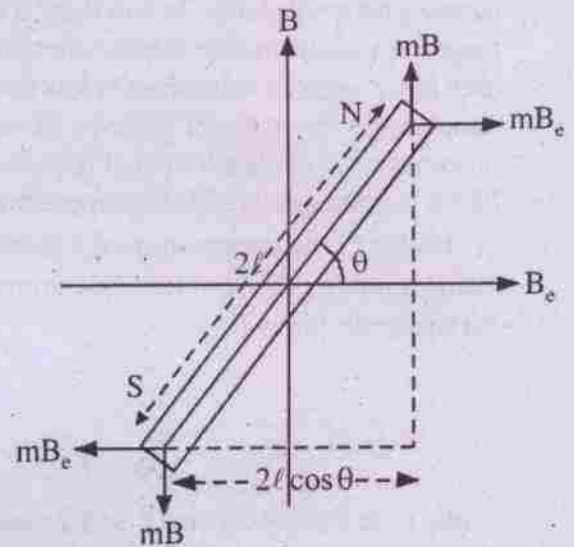

Fig. 4.15

i) Restoring couple :

The field B_e acting on two poles of the magnet each of pole strength $\pm mB_e$ produces two equal and opposite forces $\pm mB_e$ forming a couple known as restoring couple since it tries to bring back the magnet in the direction of B_e which is usually horizontal component of earth's magnetic field. The torque of the restoring couple is

$$\tau_1 = mB_e \cdot 2l \sin \theta \quad \dots(4.35.2)$$

where $2l$ is the magnetic length of the magnet.

ii) Deflecting couple :

The field B produces two equal and opposite forces $\pm mB$ forming a couple known as deflecting couple as it tries to increase the angle of rotation of the magnet θ . The torque of the deflecting couple is

$$\tau_2 = mB \cdot 2\ell \cos\theta \quad \dots(4.35.3)$$

When these two couples are equal and opposite, the magnet comes to equilibrium position making an angle θ with the magnetic field B_e . For equilibrium of the magnet,

$$2m B \ell \cos\theta = 2mB_e \ell \sin\theta$$

$$\text{or} \quad B = B_e \tan\theta \quad \dots(4.35.4)$$

Principle of tangent galvanometer is based on the tangent law. The pivoted magnet of the tangent galvanometer is subjected to two rectangular fields - horizontal component of earth's magnetic field B_e and field B due to a circular coil carrying current i ,

$$B = \frac{\mu_0 n i}{2a} \quad \dots(4.35.5)$$

where n is the number of turns in the coil and a is its radius. When the magnet of tangent galvanometer is in equilibrium, using tangent law (4.35.4), we have

$$\frac{\mu_0 n i}{2a} = B_e \tan\theta$$

$$\text{or} \quad i = \left(\frac{2aB_e}{\mu_0 n} \right) \tan\theta$$

$$= K \tan\theta \quad \dots(4.35.6)$$

where $K = \frac{2aB_e}{\mu_0 n}$ is a constant for a given tangent galvanometer and is known as reduction factor of the galvanometer. Knowing K , current can be measured in terms of θ .

If $\theta = 45^\circ$, $i = K$. K is the value of the current needed to produce a deflection of 45° in the tangent galvanometer.

SUMMARY

MAGNET

A body which can attract iron filings is called a magnet. Natural and artificial magnets are two varieties of magnets.

Properties of a magnet :

- i) It has two poles : south and north.
- ii) Attractive power is maximum at the poles
- iii) A freely suspended magnet is always aligned in north-south direction of the earth.
- iv) Like poles repel and unlike poles attract.
- v) Poles always exist in pairs. No monopole exists.

MAGNETIC DIPOLE

Two opposite poles of equal strength separated by a small distance is a magnetic dipole. Magnetic moment $M=2m \ell$. It is a vector. Its direction is from south pole to north pole. Its unit is Am in SI and abA-cm in cgs. (emu)

MAGNETIC FIELD

The modified region of space around a magnet is said to be its magnetic field. It is pictorially represented by magnetic lines of force.

Properties of lines of force

- i) They are continuous curves leaving from north pole and entering at south pole.
- ii) Tangent at any point on the line of force gives the direction of magnetic field at that point.
- iii) Lines of force never intersect.
- iv) In a region, crowded lines of force indicate strong field whereas widely separated lines of force indicate weak field.

- v) Number of lines of force per unit normal area is proportional to the field strength.

COULOMB'S LAW OF MAGNETISM

The force of attraction or repulsion between two magnetic poles is directly proportional to the product of their pole strengths and inversely proportional to the square of the distance between them.

$$F = \frac{\mu_0}{4\pi} \cdot \frac{m_1 m_2}{r^2} \quad \text{in SI system}$$

$$F = \frac{m_1 m_2}{r^2} \quad \text{in cgs system}$$

where μ_0 is known as absolute permeability of free space and its value is $4\pi \times 10^{-7}$ Wb/A-m.

MAGNETIC INDUCTION

Magnetic induction at a point in a magnetic field is the force experienced by a unit north pole placed at that point

$$\vec{B} = \frac{\vec{F}}{m}$$

It is a vector. Its unit in S.I. is N/A-m or Tesla (T) or Wb/m². Its unit in c.g.s is dyne / abA-cm or gauss.

$$1 \text{ Tesla} = 10^4 \text{ gauss}$$

Magnetic induction due to an isolated magnetic pole

i) in free space $\vec{B}_0 = \frac{\mu_0}{4\pi} \cdot \frac{m}{r^3} \vec{r}$

ii) in a magnetic medium $\vec{B} = \frac{\mu}{4\pi} \cdot \frac{m}{r^3} \vec{r}$

MAGNETIC INTENSITY (\vec{H})

It is the ratio of magnetic induction and permeability of the medium.

In free space $\vec{H} = \frac{\vec{B}_0}{\mu_0} = \frac{1}{4\pi} \cdot \frac{m}{r^3} \vec{r}$

In a medium $\vec{H} = \frac{\vec{B}}{\mu} = \frac{1}{4\pi} \cdot \frac{m}{r^3} \vec{r}$

\vec{H} is independent of the material of the medium. Its unit in (i) SI is Am⁻¹ and (ii) cgs is oersted (oe)

$$1 \text{ Am}^{-1} = 4\pi \times 10^{-3} \text{ oe}$$

MAGNETIC POTENTIAL (V)

Magnetic potential at a point is the work done in bringing a unit north pole from infinity to that point.

Magnetic potential due to a pole of strength m at a distance r is

$$V = \frac{\mu_0}{4\pi} \cdot \frac{m}{r}$$

It is a scalar and its unit in SI is J A⁻¹ m⁻¹.
Magnetic field due to a bar magnet

a) in end-on position is

$$B_p = \frac{\mu_0}{4\pi} \cdot \frac{2Md}{(d^2 - \ell^2)^2}$$

b) in broad-side-on position is

$$B_Q = \frac{\mu_0}{4\pi} \cdot \frac{M}{(d^2 + \ell^2)^{3/2}}$$

Due to a short magnet, for same distance

$$B_p = 2B_Q \quad (\text{for } \ell \ll d)$$

Torque (T) experienced by a magnet or magnetic dipole in a uniform magnetic field (B) is

$$T = MB \sin \theta$$

$$\vec{T} = \vec{M} \times \vec{B}$$

Work done in rotating a magnet in a uniform magnetic field from an angular position θ_1 (w.r.t magnetic field) to θ_2 is

$$W = MB(\cos \theta_1 - \cos \theta_2)$$

Potential energy of a magnet in a uniform magnetic field is

$$U = -\vec{M} \cdot \vec{B}$$

TERRESTRIAL MAGNETISM

It is the magnetism of the earth. Magnetic field of the earth is completely specified by three quantities known as magnetic elements of the earth. They are

a) Declination or variation (θ)

It is the angle between magnetic meridian and geographical meridian at a place.

b) Inclination or dip (δ)

It is the angle made by earth's magnetic field with the horizontal direction in the magnetic meridian at a place.

It varies from 0° (at the magnetic equator) to 90° (at the magnetic poles).

c) Horizontal component of earth's magnetic field (B_H)

It is the component of earth's magnetic field in the horizontal direction in the magnetic meridian.

$$\tan \delta = \frac{B_V}{B_H}, \quad B = \sqrt{B_V^2 + B_H^2}$$

where B_V is the vertical component of earth's magnetic field.

APPARENT DIP

It is the angle of dip at a place in a vertical plane other than magnetic meridian.

NEUTRAL POINT

It is a point around a magnet where resultant magnetic field (due to the earth and the magnet) is zero.

A bar magnet, kept on the surface of the earth, will have two neutral points.

A long bar magnet kept vertically on the surface of earth will have only one neutral point on the surface of the earth.

Magnetic properties of materials

Intensity of magnetization (I)

It is the magnetic moment developed per unit volume of a material in a uniform magnetic field.

$$I = \frac{M}{V} = \frac{m}{a}$$

where m is the pole strength, a is the area of cross section of the bar magnet.

Magnetic induction or magnetic flux density (B)

$$B = \mu_0(H + I)$$

Magnetic susceptibility χ

$$\chi = \frac{I}{H}$$

Magnetic permeability

$$\text{In free space, } \mu_0 = \frac{B_0}{H_0}$$

$$\text{In a magnetic medium } \mu = \frac{B}{H}$$

$$\mu = \mu_0(I + \chi)$$

$$\mu_r = \mu/\mu_0 = 1 + \chi$$

where μ_r is the relative permeability of a material. It is a pure number.

CURIE'S LAW

The susceptibility of an unsaturated paramagnetic substance is inversely proportional to its absolute temperature.

$$\chi = \frac{C}{T} \quad \text{where } C \text{ is Curie constant.}$$

Classification of magnetic materials

According to response of substances to magnetic field, these are classified into three groups:

i) Diamagnetic substances

The substances which acquire a weak magnetism opposite to magnetising field are known as diamagnetic substances.

Properties of diamagnetic substances

- These are weakly repelled by strong magnets.
- $I = \chi H$ where $\chi < 0$.
- Magnetic field inside the diamagnetic material is less than that outside i.e. $B < \mu_0 H$.
- $\mu_r < 1$
- Its susceptibility is independent of temperature.
- Diamagnetism is a universal phenomenon.

ii) Paramagnetic substances

Substances which acquire a weak magnetism in the direction of magnetising field are known as paramagnetic substances.

Properties of paramagnetic substances

- These are weakly attracted by strong magnets
- $I = \chi H$ where $\chi > 0$
- $B > \mu_0 H$
- $\mu_r = 1 + \chi \therefore \mu_r > 1$
- $\chi \propto \frac{1}{T}$
- It is not a universal phenomenon.

iii) Ferromagnetic substances

Substances which acquire a strong magnetism in the direction of magnetising field are known as ferromagnetic substances.

Properties of ferromagnetic substances

- These are strongly attracted by magnets.

- I is not a single valued function of H.
- At Curie temperature, a ferromagnetic material gets converted into paramagnetic material.
- $B \gg \mu_0 H$
- $\mu_r = 1 + \chi$ where $\mu_r \gg 1$
- It exhibits an effect known as hysteresis unlike dia and paramagnetic substances.
- Unlike dia and paramagnetics, it consists of micro crystalline regions known as domains. In each domain, elementary dipoles moments are directed in one direction. In an unmagnetised specimen, magnetic moments in different domains are directed in random directions.

SOFT IRON

It is a ferromagnetic material. It can be easily magnetised and demagnetized. Its retentivity and coercive forces are small. It is useful for making electromagnets. It is used as a core in the coils of transformer, moving coil galvanometer etc.

STEEL

It is a hard ferromagnetic material. It can be easily magnetized but cannot be demagnetized by stray fields. Hence it is used for making permanent magnets. Its retentivity and coercive force are larger than that of soft iron.

SOLVED NUMERICAL EXAMPLES

- Two similar poles with pole strengths in the ratio of 1 : 2 are placed 1m apart. Calculate the distance of the neutral point from the smaller pole strength (neglect earth's field).

Solution :

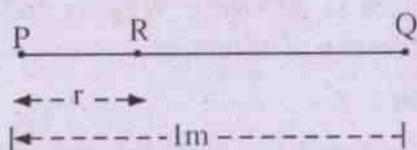

Fig. 4.16

Consider two poles of strengths m and $2m$ at the point P and Q respectively. Let R be the neutral at a distance r from P .

$$\therefore \frac{\mu_0}{4\pi} \cdot \frac{m}{r^2} = \frac{\mu_0}{4\pi} \cdot \frac{2m}{(1-r)^2}$$

$$\text{or } (1-r)^2 = 2r^2$$

$$\text{or } 1-r = \sqrt{2}r$$

$$\text{or } r = \frac{1}{1+\sqrt{2}} = \sqrt{2}-1 = 0.414 \text{ m}$$

2. A long bar magnet has poles each of pole strength $5 \text{ A}\cdot\text{m}$. Find magnetic induction at a point on its axis at a distance of 10 cm from the north pole of the magnet.

Solution :

$$\begin{aligned} \text{Magnetic induction } B &= \frac{\mu_0}{4\pi} \cdot \frac{m}{r^2} \\ &= 10^{-7} \times \frac{5}{0.1^2} = 5 \times 10^{-5} \text{ T} \end{aligned}$$

3. The magnetic moment of earth's magnetic dipole at its centre is $8.0 \times 10^{22} \text{ Am}^2$. Calculate magnetic induction at the geomagnetic poles of the earth. (Radius of earth is 6400 Km)

Solution :

Geomagnetic poles are on the surface of the earth at a distance 6400 km from the centre of the dipole of the earth.

Magnetic induction due to a short dipole at end on position is

$$\begin{aligned} B &= \frac{\mu_0}{4\pi} \cdot \frac{2M}{d^3} \\ &= 10^{-7} \times \frac{2 \times 8 \times 10^{22}}{(6.4 \times 10^6)^3} = 61 \mu\text{T} \end{aligned}$$

4. If the earth's magnetic field has a magnitude $3.5 \times 10^{-5} \text{ T}$ at the magnetic equator of the earth, what would be its value at the earth's geomagnetic poles ?

Solution :

A point on magnetic equator is broad-side-on position w.r.t. earth's magnetic dipole whereas geomagnetic poles are on its end on positions.

$$\begin{aligned} \therefore B_{\text{end-on}} &= 2 \times B_{\text{broad-side-on}} \\ &= 2 \times 3.5 \times 10^{-5} \\ &= 70 \mu\text{T} \end{aligned}$$

5. Two bar magnets each of magnetic moment M_0 are inclined to each other at an angle 60° . Find the resultant magnetic moment of the combination if their (i) south poles touch each other and (ii) south and north poles touch each other.

Solution :

Resultant magnetic moment

$$M = \sqrt{M_1^2 + M_2^2 + 2M_1M_2 \cos \theta}$$

- i) If two south poles touch each other, the angle between two magnetic moments

$$\theta = 60^\circ$$

$$\begin{aligned} \therefore M &= \sqrt{M_0^2 + M_0^2 + 2M_0^2 \times \frac{1}{2}} \\ &= \sqrt{3}M_0 \end{aligned}$$

- ii) When south and north poles of two bar magnets touch each other $\theta = 120^\circ$

$$M = M_0$$

6. Magnetic induction B and the magnetic intensity H in a material are found to be 1.6 T and 1000 Am^{-1} respectively. Calculate relative permeability μ_r and susceptibility χ of the material. What is the nature of the material?

Solution :

Absolute permeability of the material

$$\mu = \frac{B}{H} = \frac{1.6}{1000} = 1.6 \times 10^{-3} \text{ TA}^{-1} \text{ m}$$

Its relative permeability

$$\mu_r = \frac{\mu}{\mu_0} = \frac{1.6 \times 10^{-3}}{4\pi \times 10^{-7}} = 1274$$

$$\chi = \mu_r - 1 = 1273$$

nature of material is ferromagnetic as its susceptibility $\chi \gg 1$.

7. A magnetic dipole of magnetic moment 0.72 Am^2 is placed horizontally with its north pole pointing towards south. Find the positions of the neutral points if the horizontal component of earth's magnetic field at the place is $18 \mu\text{T}$.

Solution :

If the dipole is placed with its north pole pointing south, two neutral points are formed on either side of the magnet along its axis. Let d be the distance of each neutral point from the mid point of magnetic dipole.

$$\therefore \frac{\mu_0}{4\pi} \cdot \frac{2M}{d^3} = B_H$$

$$d^3 = \frac{\mu_0}{4\pi} \cdot \frac{2M}{B_H} = 10^{-7} \times \frac{2 \times 0.72}{18 \times 10^{-6}}$$

$$= 0.008$$

$$d = 0.2 \text{ m}$$

8. A ship is travelling due east according to mariners compass. If the declination at that place is 20° west. What is the actual direction of its motion.

Solution :

Let dotted line $N'S'$ represent magnetic meridian which makes an angle 20° with Geographic meridian NS fig. 4.17 i.e. declination of the place is 20° west. As the ship is travelling due east according to the mariner's compass i.e. at right angles to $N'S'$, the actual direction of the ship is as shown in the fig. i.e. 20° north of east.

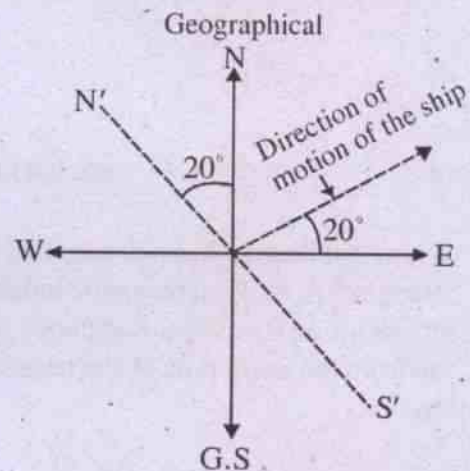

Fig. 4.17

9. The susceptibility of magnesium at 300K is 1.2×10^{-5} . At what temperature will its susceptibility be 1.8×10^{-5} .

Solution :

Magnesium is a paramagnetic substance.

$$\text{Its susceptibility } \chi_1 = \frac{C}{T_1}$$

$$\therefore \frac{\chi_2}{\chi_1} = \frac{T_1}{T_2}$$

$$\begin{aligned}\therefore T_2 &= T_1 \times \frac{\chi_1}{\chi_2} \\ &= 300 \times \frac{1.2 \times 10^{-5}}{1.8 \times 10^{-5}} \\ &= 200 \text{ K}\end{aligned}$$

10. The coercive force for a certain permanent magnet is 4.0×10^4 A/m. This magnet is placed inside a long solenoid of 40 turns / cm. What current in the

solenoid is required to demagnetise it completely.

Solution :

$$\text{Coercive force } H = 4.0 \times 10^4 \text{ Am}^{-1}$$

$$\text{In solenoid } B_0 = \mu_0 ni,$$

$$H = \frac{B_0}{\mu_0} = ni = 40 \times 10^2 \times i = 4 \times 10^4$$

$$\therefore i = 10 \text{ A}$$

MODEL QUESTIONS

A. Multiple Choice Type Questions :

1. Magnetism in a substance is due to
 - a) Orbital motion of electrons only
 - b) spin motion of electrons only
 - c) both orbital and spin motion of electrons.
 - d) None of the above cause magnetism.
2. A permanent magnet
 - a) attracts strongly a ferromagnetic substance.
 - b) attracts weakly a paramagnetic substance.
 - c) repels weakly a diamagnetic substance.
 - d) All the above are correct.
3. Unit of magnetic intensity at a point in a magnetic field in c.g.s system is
 - a) oersted
 - b) gauss
 - c) Tesla
 - d) Am^{-1}
4. The angle between the magnetic moment of a bar magnet and its magnetic field at a point on its broad-side-on position is
 - a) 0°
 - b) 45°
 - c) 90°
 - d) 180°
5. Magnetic field due to a short magnet at a point on its axis at a distance x cm from its mid point is 8 gauss. At a distance $2x$ cm on its axis, the magnetic field is
 - a) 4 gauss
 - b) $2V_2$ gauss
 - c) 2 gauss
 - d) 1 gauss
6. Geometric length of a bar magnet is 10cm. Its magnetic length is approximately
 - a) 10 cm
 - b) 9 cm
 - c) 5 cm
 - d) 8.4 cm
7. Domain structure is the characteristic of a
 - a) ferromagnetic substance
 - b) Paramagnetic substance
 - c) diamagnetic substance
 - d) All the above
8. If the magnetic moment of atoms of a substance is zero. The substance is a
 - a) ferromagnetic
 - b) paramagnetic
 - c) diamagnetic
 - d) all the above
9. Susceptibility of a substance is independent of temperature. The substance may be
 - a) paramagnetic
 - b) diamagnetic
 - c) ferromagnetic
 - d) all the above
10. Curie-Weiss law is applicable for a _____ substance.
 - a) ferromagnetic
 - b) paramagnetic
 - c) both of the above
 - d) non of the above
11. A paramagnetic substance is kept in a magnetic field. The temperature of the substance is decreased till its magnetization becomes constant. If the magnetic field is now increased, its magnetization
 - a) will increase
 - b) decrease
 - c) remain constant
 - d) may increase or decrease

22. At a place, apparent dips at two mutually perpendicular planes are 30° and 60° . The true dip of the place is
- a) $\cot^{-1} \sqrt{\frac{10}{3}}$ b) $\cot^{-1} \frac{10}{3}$
- c) $\tan^{-1} \sqrt{\frac{10}{3}}$ d) $\tan^{-1} \frac{10}{3}$

B. Very Short Answer Type Questions :

1. What is a magnet ?
2. What is magnetism ?
3. What are natural magnets and what are their demerits ?
4. What are the basic properties of magnets ?
5. Name the scientist who discovered the earth's magnetism ?
6. What is an artificial or permanent magnet ?
7. What do you understand by term 'poles' in the context of a magnet ?
8. Are the two poles of a magnet separable ? If not, why ?
9. What is a magnetic dipole ?
10. Define a unit pole.
11. Define magnetic field.
12. What is the magnetic length of a bar magnet ? Is it the same as its geometric length.
13. What are the SI units of B, M and μ_0 ?
14. What is a geographical axis ?
15. What is a magnetic axis ?
16. What is a magnetic meridian ?
17. What is a geographic meridian ?
18. Does the magnetic axis of a freely suspended magnet exactly show the geographic north-south direction ?
19. Define declination. [CHSE 94 S]
20. Define angle of dip or inclination. [CHSE 94 A]
21. What is the angle of dip at (i) magnetic equator and (ii) at the magnetic pole ? [CHSE of instant]
22. Define the strength of earth's magnetic field.
23. What are magnetic elements of the earth ?
24. Can two magnetic lines of force ever intersect each other ?
25. What are diamagnetic substances ? Give some examples.
26. Define paramagnetic substances ? Give some examples. [CHSE 90 S]
27. What are ferromagnetic substances ? Give some examples.
28. What is magnetic permeability ? [CHSE 89 S, 2002 A]
29. Define magnetic susceptibility. [CHSE 90 A]
30. Define magnetic induction. [CHSE 95 S]
31. Write a relation between B, B_H and δ of earth's magnetic field.
32. How the relative permeability of a substance is related to its susceptibility ?
33. Where on the earth's surface is the value of angle of dip maximum ? [CBSE 2003]
34. What type of magnetic material is used for making a permanent magnet ? [CBSE 1996]

OR

Mention two characteristics of a material for making a permanent magnet ?

[CBSE 2010]

35. What is the value of angle of dip at any place situated on the magnetic equator of the earth ? [CBSE 1995]

36. In which direction would a compass needle align if taken to geographic (i) north pole and (ii) south pole.

[CBSE 2000]

C. Short Answer Type Questions :

1. Distinguish between a magnetic dipole and an electric dipole.

2. Define magnetic dipole moment. Is it a scalar or vector ? What is its unit ?

3. Write the expression for the torque acting on a magnetic dipole placed in a uniform magnetic field ?

4. State Coulomb's law of force between two magnetic poles, write the expression in vector form.

5. Define magnetic field intensity of a magnetic pole. Also give its symbol, unit and direction.

6. Define magnetic lines of force. Depict the magnetic lines of force (i) due to north pole (ii) due to south pole and (iii) due to a bar magnet, its north pole pointing North.

7. Give some important properties of lines of force.

8. What happens to its magnetic moment and pole strength when a bar magnet is cut into two pieces :

(i) transverse to its length

(ii) along its length ?

9. Name the three independent quantities conventionally used to specify the earth's magnetic field.

10. The angle of dip at a location in southern India is about 18° . Would you expect a greater or lower dip angle in Delhi ?

11. Distinguish between diamagnetic and paramagnetic substances. [CHSE 98 A]

12. State the relation between permeability and susceptibility of a magnetic substance. [CHSE 98 A]

13. What is the difference in the nature of susceptibility of diamagnetic and paramagnetic substances. [CHSE 96 S]

14. Compare the susceptibilities of dia, para and ferro magnetic substances.

[CHSE 94 A]

15. A magnet of length $2l$ and pole strength m makes an angle θ with a uniform magnetic field of strength H . What is the value of the couple exerted on the magnet ? [CHSE 99 A]

16. Express - angle of dip in terms of horizontal and vertical components of earth magnetic field.

17. What is the permeability of a substance whose susceptibility is 21 ?

[CHSE 92 A]

18. Compare the permeabilities of dia, para and ferromagnetic substances.

[CHSE 94 A]

19. What will happen if a diamagnetic bar is suspended in a uniform magnetic field ?

[CHSE 2000]

20. When two magnetic poles of different pole strengths are placed at a distance of 3 cm from each other in air, the effective

force acting between them is $\frac{4}{3}$ CGS units. Find the pole strength for both if their sum is 7 CGS units. [CHSE 2002]

21. How dose the (i) pole strength and (ii) magnetic moment of each part of a bar magnet change if it is cut into equal pieces transverse to length ? [CBSE 2003]
22. The magnetic lines of force prefer to pass through iron than air. Explain why ?

[CBSE 1998,1999]

23. A hypothetical bar magnet (AB) is cut into two equal parts. One part is kept over the other, so that pole C_2 is above C_1 . If M is the magnetic moment of the original magnet, what would be the magnetic moment of the combination, so formed ?

[CBSE Sample Paper]

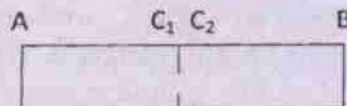
**D. Numerical Problems :**

- Find the force between two poles of strength 4 Am and 9 Am placed at a distance 6.0 cm apart.
- Two poles one of which is 4 times as strong as the other exert on each other a force equal to 50 mgwt when placed 10 cm apart. Find the strength of each pole.
- A short bar magnet placed with its north pole pointing south has a neutral point at 12.6 cm from its mid point. If the poles are reversed, find the distance of a neutral point.
- Horizontal and vertical components of earth's magnetic field at a place are $36\mu\text{T}$ and $18\mu\text{T}$ respectively. Find angle of dip and earth's resultant magnetic field.
- The magnetic field B and magnetic intensity H in a material are found to be 2T and 500 Am^{-1} respectively. Calculate relative permeability and susceptibility of the material.

- A bar magnet of moment 10 Am^2 is bent 90° at its mid point. What is the magnetic moment of the bent magnet ?
- Find the intensity of magnetization if the pole strength of a magnet of cross sectional area 1.0 cm^2 is 2 Am.
- A bar magnet of pole strength 10 Am and magnetic moment 1.0 Am^2 is cut into 4 equal parts by cutting it perpendicular to length and breadth. What will be the pole strength and the magnetic moment of each part.
- Calculate the force on a magnetic pole of strength 20 Am lying at a distance of 16 cm in front of a magnet of magnetic length 24 cm and pole strength 50 Am.
- The magnetic moment of a short magnet is 8 Am^2 . What is the magnetic induction at a point 20 cm away from its mid point on its (a) axial point (b) equatorial point ?
- Each atom of an iron bar of volume 5 cm^3 has a magnetic moment $1.8 \times 10^{-23}\text{ Am}^2$. What will be the magnetic moment of the bar in the state of magnetic saturation.
[Density of iron = $7.8 \times 10^3\text{ kg/m}^3$, Atomic weight of iron = 56, Avogadro's number, $N = 6.02 \times 10^{23}\text{ / gm-mole}$.
Hint : Magnetic moment at saturation = sum of atomic moments of all atoms]
- A bar magnet of magnetic moment 12.0 Am^2 is free to rotate about a vertical axis passing through its centre. The magnet is released from rest from east-west direction. Find kinetic energy of the magnet as it takes north-south position if horizontal component of earth's magnetic field is $30\mu\text{T}$.
- The apparent dip in a plane making an angle of 60° with the magnetic meridian is $\tan^{-1}(2)$. Find the value of true dip.

14. A compass needle of magnetic moment 60 Am^2 pointing geographical north at a certain place where the horizontal component of earth's magnetic field is $40 \mu\text{T}$, experiences a torque of $1.2 \times 10^{-2} \text{ Nm}$. What is the declination of the place.
15. An iron bar 12 cm long on being placed with its length parallel to a uniform magnetic field of 10 Am^{-1} is magnetised and the strength of the field due to the bar at a point on its axis at a distance of 25 cm from its middle point is found to be 20 Am^{-1} . If the area of cross section of the bar is 0.3 cm^2 , calculate the susceptibility of iron.
16. The vertical component of the earth's magnetic field at a given place is $\sqrt{3}$ times its horizontal component. If total intensity of earth's magnetic field at the place is 0.4 G find the value of (i) angle of dip (ii) the horizontal component of earth's magnetic field. [CBSE Sample Paper]
17. The horizontal component of earth's field at a given place is $0.4 \times 10^{-4} \text{ Wb/m}^2$ and angle of dip is 30° . Calculate the value of (i) vertical component (ii) Total intensity of earth's magnetic field. [CBSE 2003]

E. Long Answer Type Questions :

1. Deduce an expression for magnetic intensity at a point on the broad-side-on position due to a bar magnet.
[CHSE 96 A]
2. Define magnetic intensity at a point in a magnetic field. Deduce an expression for the magnetic field intensity at a point in the end-on-position due to bar magnet.
[CHSE 2000 A]
3. What do you mean by end-on and broad-side-on positions of a bar magnet ? Deduce an expression for the magnetic

intensity at a point in the broad-side-on position due to a bar magnet.

[CHSE 99 instant]

4. Show that magnetic intensity in the end-on position due to a short bar magnet is twice the intensity in the broad-side-on position at the same distance from the same magnet.
5. Define the terms : magnetic intensity, magnetic induction, intensity of magnetization, permeability and susceptibility of a magnetic substance. How they are related to each other ?
6. What do you mean by dia, para and ferromagnetic substances ? Give two examples in each case.
7. What do you mean by diamagnetism ? Show that it is an universal effect. Discuss properties of diamagnetic substances.
8. Iron is a ferromagnetic substance. Can it be converted into a paramagnetic substance ? If so, under what condition and why ? Can we have a ferromagnetic substance in a liquid form ?
9. Describe the properties which distinguishes a substance whether it is a dia, para or ferromagnetic substance.
10. Define magnetic elements of the earth. Why they are so called ?

F. True - False - Type Questions

1. The angle of dip at magnetic pole is zero.
2. The line on earth's surface joining the points where the field is horizontal is called magnetic meridian.
3. The magnetic susceptibility of a para magnetic material changes inversely as the absolute temperature.
4. Magnetisation and demagnetisation of soft iron is easier as compared to steel.

5. Magnetism in a substance is due to orbital motion of electron only.
6. Unit of magnetic intensity at a point in a magnetic field in C.G.S system is orested.
7. Curie-Weiss law is applicable for ferromagnetic substance.
8. Diamagnetism occurs in all materials .
9. Copper is a diamagnetic substance.
10. Susceptibility is positive for diamagnetic substance.

G. Fill - in - Blank - Type Questions

1. The unit of magnetic dipole moment is.....
2. The angle of dip at magnetic pole of earth is and at the equator is
3. Diamagnetic substances when placed in a magnetic field, are magnetised in the direction..... to the magnetic field.
4. Paramagnetic metarials when placed in a magnetic field, are magnetised in the direction..... to the magnetic field.

5. The angle between the magnetic moment of a bar magnet and its magnetic field at an equatorial point is

H. Correct the following sentences :

1. Unit of magnetic intensity in S.I system is gauss.
2. Curie-Weiss law is applicable for diamagnetic substances.
3. $B = \mu_0(2 + \chi)H$, where B is magnetic induction, H is magnetizing field, and χ is magnetic susceptibility.
4. Curie's law states $\chi = C/T^2$, where χ is magnetic susceptibility, T is absolute temperature and C is Curie's constant.
5. A magnetic dipole consists of two equal charges separated by a short distance.
6. In the relation $B = \mu H$, μ is called permitivity.

ANSWERS

A. Multiple Choice Type Questions :

1. (c) 2. (d) 3. (a) 4. (d) 5. (d) 6. (d) 7. (a) 8. (c)
 9. (b) 10. (a) 11. (c) 12. (c) 13. (c) 14. (a) 15. (d) 16. (c)
 17. (b) 18. (d) 19. (c) 20. (c) 21. (d) 22. (a)

D. Numerical Problems :

1. 10^{-3} N
 2. 3.5 Am, 14 Am
 3. 10 cm
 4. $\delta = \tan^{-1} 0.5 = 29.5^\circ$, $B = 40.2 \mu\text{T}$
 5. $\mu_r = 3183$, $X = 3182$
 6. $5\sqrt{2}$ Am²
 7. 2×10^4 Am⁻¹
 8. 5 Am, 0.25 Am²
 9. 3.0×10^{-3} N
 10. 2.0×10^{-4} T, 1.0×10^{-4} T
 11. 7.55 A. m²
 12. 360 μJ
 13. 45°
 14. 30°
 15. 4800
 16. 60, 0.2 G,
 17. 0.23×10^{-4} wb/m², 0.46×10^{-4} wb/m²
- F. (1) False (2) False (3) True (4) True (5) False (6) True (7) True (8) True (9) True (10) False.
- G. (1) ampere/meter² (2) 90° , zero (3) 90 (4) parallel (5) 180° .

5

Electric Current

Introduction :

In some of the preceding chapters we have studied that electric charges at rest produce electric field. We have discussed the properties of this field, its interaction with other charges and the potential energy associated with these charges. This background enables us to study the charges in motion which is the cause of electric current. Almost all marvels of electricity and technological advances in the modern world may be attributed to this current. In this new chapter let us make a discussion on the production of steady current and study the related concepts like electric circuit, drift velocity, current density and Ohm's law etc.

5.1 Electric Current :

Electric current is defined as the net time rate of flow of charge carriers through an area of a conducting medium. Conventionally, the direction in which positive charge carriers would move determines the sense of current. It is our common experience that metals like copper, iron, aluminium, silver etc. are treated as good conducting media because of the presence of free electrons (i.e. valence electrons) in them. In such a conductor of definite shape and size the no. of free electrons is quite large. These electrons move inside it like the free molecules of a gas. The motion is random and hence there is no net flow of charge through any section of the conductor in any direction. This results in no current.

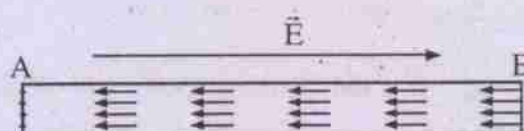

Fig. 5.1

Such a conductor like AB (fig. 5.1) is an equipotential surface having no electric field inside it.

Let AB be subjected to an external electrical field \vec{E} as shown in fig. 5.1. The free electrons in it experience a force in the opposite direction of \vec{E} . As a result there is gradual accumulation of negative charge at the end A and deficit of such charges at the end B. This creates a potential difference between A and B and gives rise to an internal electric field \vec{E}' within AB from B to A. Clearly \vec{E}' is in opposite direction of \vec{E} . As \vec{E}' increases in magnitude, the process of accumulation of charge slows down, finally becoming zero when $\vec{E}' = -\vec{E}$. Electric current exists within the conductor during the process of such redistribution of charges. It is not constant though unidirectional. It exists for a very short time as the entire process is almost instantaneous. The potential energy stored in the original charge distribution within AB is used during the process of such redistribution of the charges.

A steady flow of charge within AB is possible if the ends A and B of the conductor are connected to the two sides of a device ϵ which continuously drags the -ve charge carriers from the end A and supplies them to the end B at a constant rate through a path other than AB, (fig. 5.2). In other words, ϵ does not allow the field \vec{E} to be formed. Then there is a

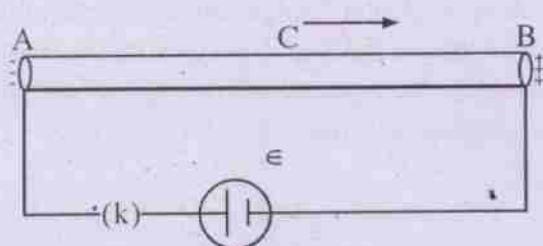

Fig. 5.2

continuous flow of -ve charge carriers from the end B to the end A via., the point C. The device ϵ is called a source of electromotive force (e.m.f.). Energy is supplied to the mobile charge carriers by the source of emf. We shall make more discussion about these sources in the next chapter.

The entire cyclic path AKEBCA is known as a **simple circuit** (fig. 5.2). The symbol K in the circuit is called a key or switch. It is used at the time of making or breaking the circuit.

Expression for current :

Let Q be the quantity of charge flowing steadily through any section of the conductor in time t . Then the steady current I in the conductor is given by

$$I = \frac{Q}{t} \quad \dots(5.1.1)$$

When the current is not steady with time we may express the instantaneous current i as

$$i = \lim_{\Delta t \rightarrow 0} \frac{\Delta Q}{\Delta t} \quad \dots(5.1.2)$$

Where ΔQ is the small quantity of charge that flows in a short time Δt which may be taken as

small as possible. In such a case eqn. 5.1.1 represents the average current during the interval t .

Unit of current

The S.I. unit of current is called 'ampere' (A). It is taken as one of the basic units now-a-days like metre or kilogram. The dimension of current is written as A. 'Ampere' has been named after the French physicist Andre Marie Ampere. It has been defined on the basis of the magnetic force existing between two current carrying parallel wires and will be described in detail in chapter 8. However, one ampere of current is equivalent to the rate of flow of one coulomb of charge per second through any section of a conducting path.

$$1 \text{ amp.} = \frac{1 \text{ coul.}}{1 \text{ sec.}} \quad \dots(5.1.3)$$

Since the magnitude of charge on an electron is 1.6×10^{-19} coulomb, one ampere is also equivalent to a rate of flow of 6.24×10^{18} electrons per second. It is thus a very big unit of current. Hence smaller units like **miliampere** (i.e. $\text{mA} = 10^{-3} \text{ A}$), **microampere** (i.e. $\mu\text{A} = 10^{-6} \text{ A}$), **nano ampere** (i.e. $\text{nA} = 10^{-9} \text{ A}$) and **picoampere** (i.e. $\text{pA} = 10^{-12} \text{ A}$) are often used in different situations.

Electric current has two other C.G.S. units like "Stat ampere" and "ab-ampere".

$$1 \text{ stat amp.} = \frac{1 \text{ stat coul.}}{1 \text{ sec.}}$$

$$1 \text{ ab amp.} = \frac{1 \text{ e.m.u of charge}}{1 \text{ sec.}}$$

It may be mentioned here that

$$1 \text{ coulomb} = 3 \times 10^9 \text{ stat coulomb and} \\ 10 \text{ coulomb} = 1 \text{ e.m.u. of charge.}$$

The C.G.S. units of current are hardly used now-a-days. Let us therefore use 'ampere'

as the unit of current through-out this book and use the symbol A for it.

Ex. 5.1.1 A charge of $20 \mu\text{C}$ flows through a conductor connected in a simple circuit in 2 seconds. Find the average current in the circuit. Calculate the no. of electrons passing through any section of the conductor per sec.

The average current = Q/t

$$= \frac{20\mu\text{C}}{2\text{s}}$$

$$= \frac{20 \times 10^{-6}\text{C}}{2\text{s}}$$

$$= 10^{-5}\text{A} = 10\mu\text{A}$$

$$1\text{A} = 6.24 \times 10^{18} \text{ electrons / sec.}$$

$$\therefore 10^{-5}\text{A} = 6.24 \times 10^{18} \times 10^{-5} \text{ electron/sec}$$

$$= 6.24 \times 10^{13} \text{ electrons / sec.}$$

Conventional direction of current :

As stated earlier electric current is produced mostly by the motion of free electrons in a conductor which is connected in a circuit. These electrons are -ve charge carriers and hence move in the opposite direction of the applied electric field. In gaseous conductors and electrolytes both types of charge carriers move to make current. The positive ions move in the direction of the field \vec{E} whereas the negative ions move in the opposite direction. Holes which are +ve charge carriers each having the magnitude of charge of an electron, move in the direction of \vec{E} in semi conductors of p-type. However, all these facts were discovered much later after the discovery of electric current. Hence "THE DIRECTION OF FLOW OF A POSITIVE CHARGE IS REGARDED AS THE CONVENTIONAL DIRECTION OF CURRENT." The suggestion was due to Benjamin Franklin and was accepted by the

then scientific community. It has been retained since then because of its historical importance. One advantage of this choice is that it always determines the flow of charge (i.e. +ve charge) from a point of higher potential to a point of lower potential. It is analogous to the flow of water from a higher level to a lower level.

Following this convention the direction of flow of actual charge carriers in metallic conductors i.e. the free electrons is in a direction opposite to the conventional direction of current. This is shown in fig. 5.3.

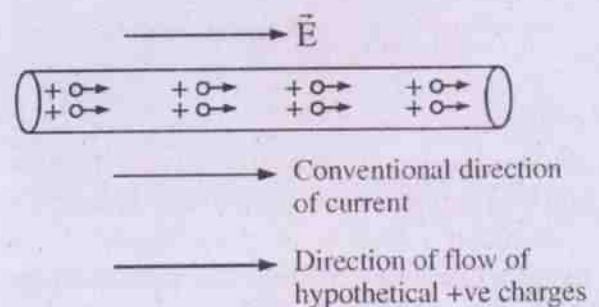

Fig. 5.3 (a)

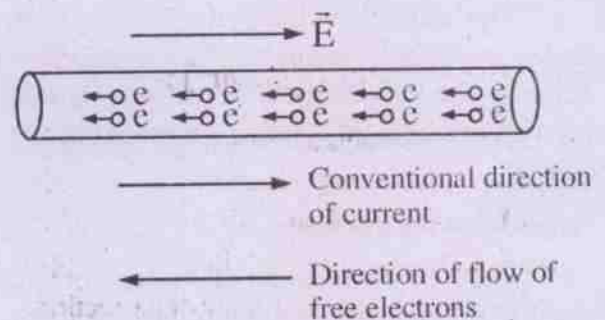

Fig. 5.3 (b)

However, the term direction of current is a misnomer since current is not a vector quantity. It is a scalar because of the followings.

- i) Currents add like scalars. When a number of conductors carrying different currents meet at a point, the total current becomes the algebraic sum of all the currents.

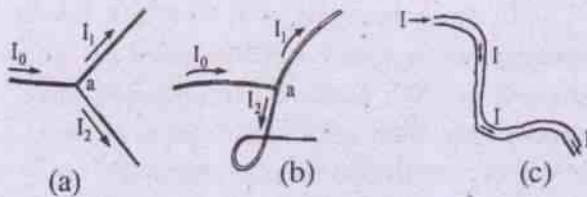

Fig. 5.4

This is shown in fig. 5.4a where $I_0 = I_1 + I_2$.

- ii) Even if a conductor is bent in different ways, the current I has the same value at all cross sections of the conductor in a circuit. This is shown in fig. 5.4.b
- iii) In the mathematical expression for current $I = q / t$, both q and t are scalar quantities. Hence current is a "scalar".

"Direction of current" simply means the sense of current.

A current which does not have a change in its sense is called direct current or d.c.

A current which changes its sense with time at the same cross section, is called alternating current or a.c.

5.2 The current density vector \vec{J} :

Electric current is a macroscopic quantity which gives the amount charge flow per unit time through any section of area 's' of a conductor. Current density \vec{J} is the microscopic quantity which exists at every point of the section in the path of charge flow. It may be broadly defined as

"the rate of charge flow per unit area of cross section of the path in the direction of the applied electric field \vec{E} , when the area is held perpendicular to \vec{E} .

The value of \vec{J} may vary from point to point over the section and \vec{J} at a point may not be perpendicular to any small cross sectional area $\hat{n}\Delta s$ surrounding the point. Then the

current dI through the small area Δs of the section is expressed as

$$dI = \lim_{\Delta s \rightarrow 0} \vec{J} \cdot \hat{n} \Delta s \quad \dots(5.2.1)$$

where \hat{n} is unit vector perpendicular to Δs as shown in fig. 5.5.

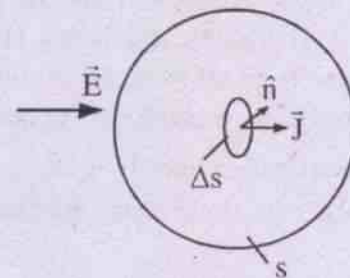

Fig. 5.5

This gives

$$I = \int_s \vec{J} \cdot \hat{n} \, ds \quad \dots(5.2.2)$$

If the direction of flow of charge at the point is perpendicular to the area Δs and the current I is uniformly distributed over the area 's', then we may write

$$I = \int_s J \, ds = J s$$

$$\Rightarrow J = I/s \quad \dots(5.2.3)$$

The unit of current density J is Ampere per meter square or A / m^2 in S.I. system. The dimension of \vec{J} is AL^{-2} .

Ex. 5.2.1 A silver wire of 1 mm^2 cross sectional area carries a current of 0.02 A . Find the magnitude of current density in the wire.

Current $I = 0.02 \text{ A} = 2 \times 10^{-2} \text{ A}$

Area $s = 1 \text{ mm}^2 = 10^{-6} \text{ m}^2$

Assuming I to be uniform over the section and \vec{J} perpendicular to the section

$$\therefore J = I/s = \frac{2 \times 10^{-2} \text{ A}}{10^{-6} \text{ m}^2} = 2 \times 10^4 \text{ A/m}^2$$

5.3. Drift velocity of electrons in a conductor

A conductor has a large number of free electrons in it. The rest of the material contains relatively heavy positive ions which vibrate about their mean positions. In the absence of an electric field the free electrons have random thermal motion like the molecules of an ideal gas. They are assumed to have all possible velocities in all possible directions. Hence the average velocity of all these electrons is zero. Such random motion produces no net current in any particular direction. If $\bar{u}_1, \bar{u}_2, \dots, \bar{u}_N$ etc. be the velocities of these electrons, then

$$\frac{\bar{u}_1 + \bar{u}_2 + \bar{u}_3 + \dots + \bar{u}_N}{N} = 0 \quad \dots(5.3.1)$$

On application of an external electric field \vec{E} , each free electron experiences a force

$$\vec{F} = -e\vec{E} \quad \dots(5.3.2)$$

so that it gets accelerated in a direction opposite to that of \vec{E} . The acceleration \vec{a} is given by

$$\vec{a} = \frac{\vec{F}}{m} = -\frac{e\vec{E}}{m} \quad \dots(5.3.3)$$

where $e \rightarrow$ electronic charge

and $m \rightarrow$ electronic mass

This increases the velocity of each electron in a direction opposite to \vec{E} till they meet inelastic collision with crystal lattices and impurities present in the conductor. As a result, their velocities are drastically reduced. However, they start afresh to collide again and the process is repeated. Because of such frequent collisions the flow of the free electrons is not an accelerated one but a steady drift or diffusion in a direction opposite to that of \vec{E} . Let us find an expression for this **drift velocity**.

If $t_1, t_2, t_3, \dots, t_N$ are average times between two successive collisions of 1st, 2nd, 3rd and the Nth electrons (relaxation times) respectively, then velocities of these electrons before each collision may be written as

$$\begin{aligned} \vec{v}_1 &= \bar{u}_1 + \vec{a} t_1 \\ \vec{v}_2 &= \bar{u}_2 + \vec{a} t_2 \\ \vec{v}_3 &= \bar{u}_3 + \vec{a} t_3 \\ &\vdots \\ \vec{v}_N &= \bar{u}_N + \vec{a} t_N \end{aligned} \quad \dots(5.3.4)$$

The average final velocity of these electrons is given by

$$\begin{aligned} \vec{v}_d &= \frac{\vec{v}_1 + \vec{v}_2 + \vec{v}_3 + \dots + \vec{v}_N}{N} \\ &= \frac{\bar{u}_1 + \vec{a}t_1 + \bar{u}_2 + \vec{a}t_2 + \bar{u}_3 + \vec{a}t_3 + \dots + \bar{u}_N + \vec{a}t_N}{N} \\ &= \frac{\bar{u}_1 + \bar{u}_2 + \bar{u}_3 + \dots + \bar{u}_N}{N} \\ &\quad + \frac{\vec{a}t_1 + \vec{a}t_2 + \vec{a}t_3 + \dots + \vec{a}t_N}{N} \end{aligned}$$

$$\text{i.e. } \vec{v}_d = 0 + \vec{a}\tau \quad \dots(5.3.5)$$

$$\text{where } \tau = \frac{t_1 + t_2 + t_3 + \dots + t_N}{N} \quad \dots(5.3.6)$$

τ is average time that has elapsed since each electron suffered its last collision and is called mean relaxation time. It is of the order of 10^{-14} second. We have from eqn. (5.3.5) and (5.3.3)

$$\vec{v}_d = \vec{a}\tau = -\frac{e\vec{E}}{m}\tau \quad \dots(5.3.7)$$

The magnitude of drift velocity is called drift speed.

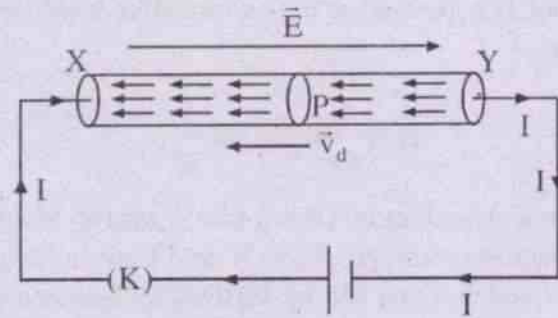

Fig 5.6

Drift speed and current :

Let us consider a straight cylindrical conductor XY of length l and area of cross section a . Let it be connected in a simple circuit as shown in fig. 5.6. The electric field within the conductor is directed from X to Y. Hence the free electrons in it are drifted from right to left. All such electrons which flow past the section at P of the conductor in time Δt , lie within a cylinder of length $v_d \Delta t$ and area of cross section s , i.e. within a volume $V = l$ of the conductor XY. If n is the number of free electrons per unit volume of the conductor, (i.e. number density of free electrons) the total number of electrons that flow past the section in time $\Delta t = nsv_d \Delta t$.

\therefore The charge ΔQ that flows past the section in time Δt is given by

$$\Delta Q = -n s v_d \Delta t \cdot e \quad \dots (5.3.8)$$

\therefore The current I in the conductor is given by

$$I = \frac{\Delta Q}{\Delta t} = n s e v_d \quad \dots (5.3.9)$$

It is seen that $I \propto v_d$, since n and S are constants for a given conductor.

Assuming a uniform distribution of current over any section of the conductor, the current density J at any point is given by

$$J = \frac{I}{s} = nev_d$$

$$\text{i.e. } \vec{J} = n e \vec{v}_d \quad \dots (5.3.10)$$

The drift speed of electrons in a metallic conductor is quite small. It varies from some fraction of a mm to a few mm.

Ex. 5.3.1 A current of 1 A exists in a copper wire of cross section 1 mm^2 . If the no. of electrons per cubic meter of copper is 8.5×10^{28} , calculate the drift speed of free electrons in the wire.

We have $I = n a e v_d$

$$\Rightarrow v_d = \frac{I}{nae}$$

Substituting for $n = 8.5 \times 10^{28}$

$$s = 10^{-6} \text{ m}^2$$

$$e = 1.6 \times 10^{-19} \text{ coul.}$$

and $I = 1 \text{ A}$

$$v_d = \frac{1\text{A}}{\frac{8.5 \times 10^{28}}{\text{m}^3} \times 10^{-6} \text{ m}^2 \times 1.6 \times 10^{-19} \text{ coul.}}$$

$$= \frac{1\text{A} \times 1\text{m}^3 \times 10^{-3}}{8.5 \times 1.6 \text{ m}^2 \cdot \text{coul.}} = 0.074 \text{ mm/s}$$

It so happens that an electron in a circuit may take quite a few hours to travel a distance of one metre. However, the changes in the electric field which produce changes in flow rate of charges are propagated with a speed nearly equal to the speed of light. That is why an electric bulb glows almost instantly as the circuit is switched on.

5.4 Relation between \vec{J} and \vec{E} , Ohm's law:

Eqn. 5.3.10 gives the relation between current density \vec{J} and drift velocity \vec{v}_d of the

charge carriers at any point in a conductor i.e.

$$\vec{J} = n e \vec{v}_d$$

Let us use the expression for \vec{v}_d given in eq. 5.3.7. and simplify to get

$$\vec{J} = \frac{n e^2 \tau}{m} \vec{E} \quad \dots (5.4.1)$$

In the equation e and m being constants of the charge carrier and n and τ being constants for the given metallic conductor, it is seen that

$$\vec{J} \propto \vec{E}$$

$$\text{i.e. } \vec{J} = \sigma \vec{E} \quad \dots (5.4.2)$$

$$\text{where } \sigma = \frac{n e^2 \tau}{m} \quad \dots (5.4.3)$$

σ is constant for the material of the conductor and is called its **conductivity**. Further eq. 5.4.2 shows that the two vectors \vec{J} and \vec{E} are linearly related and this relation is said to be one form of the famous **Ohm's law**. Let us call it the microscopic form. The original statement of the same is as follows.

"Temperature and other physical conditions remaining constant, the current I in a conductor is directly proportional to the potential difference V between its ends."

Georg Simon Ohm gave this statement in 1826 on the basis of his experimental observations. Mathematically it may be written as

$$\begin{aligned} I &\propto V \\ \Rightarrow I &= G V \quad \dots (5.4.4) \end{aligned}$$

Written otherwise

$$V = \frac{I}{G} = R I \quad \dots (5.4.5)$$

where R and G are the constants for the given conductor at the particular temperature. R is

called its **resistance** and G , its **conductance**. One is expressed as the reciprocal of the other i.e.

$$R = \frac{1}{G} \text{ and } G = \frac{1}{R}$$

This statement of Ohm's law is said to be its macroscopic form. Here V and I are linearly related and this can be verified by measuring their values experimentally. The graph plotted between V and I is a straight line shown in fig. 5.7. The experimental arrangement is given in the form of a circuit diagram in fig. 5.8.

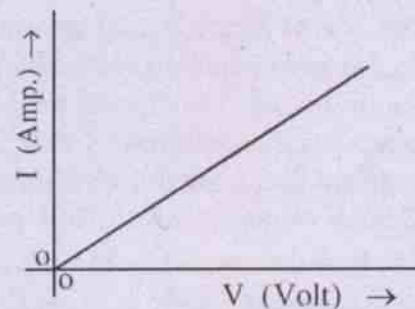
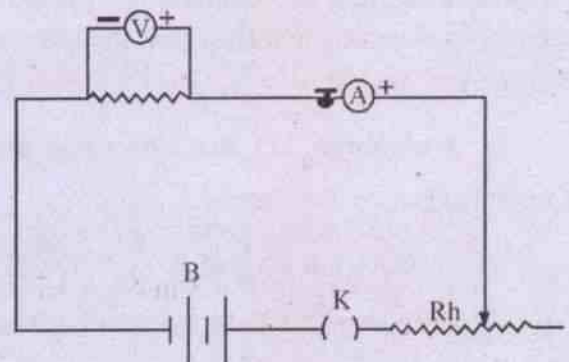

Fig. 5.7
(Linear variation of I with V)



$V \rightarrow$ Voltmeter, $A \rightarrow$ Ammeter, $B \rightarrow$ Battery
 $K \rightarrow$ Key, $Rh \rightarrow$ Rheostat
(Circuit diagram for verification of Ohm's law)

Fig. 5.8

Mathematical deduction of the law :

The macroscopic quantities V , I and R involved in Ohm's law can be related to the microscopic quantities like n , e , m , τ , and \vec{J} .

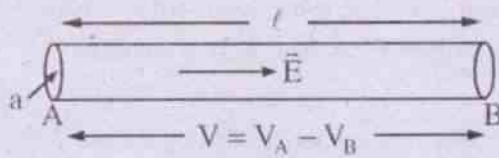

Fig. 5.9

Let us consider a segment of a straight conductor as shown in fig. 5.9. Let ℓ be its length and a , its area of cross section, when a steady potential difference $V = V_A - V_B$ is maintained between its ends, a uniform electric field \vec{E} is established along the wire. Its magnitude is given by

$$E = \frac{V}{\ell} \quad \dots (5.4.6)$$

The charge carriers (assumed to be +ve) are drifted within the conductor under the influence of \vec{E} . Assuming the current density \vec{J} at any point to be parallel to \vec{E} , the current in the conductor at any point is given by

$$I = \oint_s \vec{J} \cdot d\vec{s}$$

$$= \oint_s \sigma \vec{E} \cdot d\vec{s} \quad (\because \vec{J} = \sigma \vec{E})$$

$$\Rightarrow I = \sigma E s \quad \dots (5.4.7)$$

($\because \vec{E}$ and \vec{s} are in the same direction)

Using eq. 5.4.6 and eq. 5.4.3 in eq. 5.4.7 we have

$$I = \frac{ne^2 \tau V}{m\ell} \cdot s = \frac{ne^2 \tau s V}{m\ell} \quad \dots (5.4.8)$$

This shows that $I \propto V$ since $\frac{ne^2 \tau s}{m\ell}$ is a constant for the given conductor. Thus Ohm's law is established.

A comparison of eq. 5.4.8 with eq. 5.4.4 shows that

$$G = \frac{ne^2 \tau s}{m\ell} \quad \dots (5.4.9)$$

Hence $R = \frac{1}{G} = \frac{m\ell}{ne^2 \tau s} \quad \dots (5.4.10)$

However, Ohm's law is not valid in case of all electrical circuits. The circuits and conductors which obey Ohm's law are called **Ohmic circuits** and **Ohmic conductors** respectively. In this case I and V are linearly related as shown in Fig. 5.7. Metallic conductors like Cu, Al, Ag, Fe etc and many alloys like manganin, constantan, nichrome and brass etc. are some examples of Ohmic conductors.

When the circuit contains conductors like vacuum tubes, semiconductors, transistors, crystal rectifiers, thermistors and liquid electrolyte etc. ohm's law does not hold good. Such circuits are non-ohmic and the concerned conductors are called non ohmic conductors. The relation between V and I for some nonohmic circuits is graphically shown in fig. 5.10.

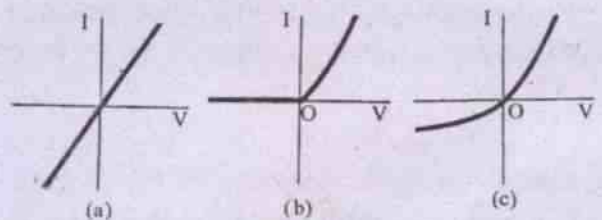

Fig. 5.10

Current - voltage relations for (a) a resistor obeying Ohm's law; (b) a vacuum diode; (c) a semiconductor diode.

5.5. Resistance and Resistivity :

The resistance of a conductor is a macroscopic electrical quantity and it is related to microscopic electrical quantities like m , n , e and τ by the eq. 5.4.10. Recalling eq. 5.4.9 and 5.4.10, let us write

$$R = \frac{m\ell}{ne^2 \tau s} = \rho \frac{\ell}{s} \quad \dots (5.5.1)$$

$$\text{and } G = \frac{n e^2 \tau s}{m \ell} = \sigma \frac{s}{\ell} \quad \dots(5.5.2)$$

Here ρ is called the **resistivity** or **specific resistance** of the material of the conductor and clearly

$$\rho = \frac{m}{n e^2 \tau} \quad \dots(5.5.3)$$

It is a constant for a given material and is related to the resistance of the conductor by eq. 5.5.1. This shows that

$R \propto \ell$ i.e. resistance of a conductor is directly proportional to its length.

and $R \propto \frac{1}{s}$ i.e. resistance of a conductor is inversely proportional to its area of cross section.

If we put $\ell = 1$ unit, $s = 1$ unit in eq. 5.5.1, we have $R = \rho$. Hence **resistivity** of a material is numerically equal to the resistance of a unit cube made out of it. It is the reciprocal of conductivity of the material.

$$\text{i.e. } \rho = \frac{1}{\sigma}$$

The values of resistivity of some known materials are given in Table 5.1.

Units and dimensions of R, G, ρ and σ :

S.I. units of current I and potential difference V have been named as Ampere (A) and Volt (V) respectively.

Since resistance $R = \frac{V}{I}$, its S.I. unit may be written as **volt / ampere** and it is called **ohm**. The symbol Ω i.e. Greek letter omega is often used for it. Conductance G of a conductor is the reciprocal of its resistance i.e. $G = \frac{1}{R}$ and

its unit is called **mho**. Thus **mho = ohm⁻¹** and the symbol S (i.e. Siemen) is used for it.

From the relation 5.5.1 we have $\rho = \frac{Rs}{\ell}$, so that the unit of resistivity in S.I. system is written as **ohm.m**. Obviously the unit of conductivity is **ohm⁻¹ . m⁻¹ = mho / m**.

As electric current is considered as a fundamental physical quantity in S.I. system of units, its dimension is written as A. We have then

the dimension of potential difference

$$V = M^1 L^2 T^{-3} A^{-1},$$

the dimension of resistance

$$R = M^1 L^2 T^{-3} A^{-2},$$

the dimension of conductance

$$G = M^{-1} L^{-2} T^3 A^2,$$

the dimension of resistivity

$$\rho = M^1 L^3 T^{-3} A^{-2} \text{ and}$$

the dimension of conductivity

$$\sigma = M^{-1} L^{-3} T^3 A^2.$$

Ex. 5.5.1 Find the resistivity and conductivity of manganin if a manganin wire of 1.75 m length and 0.07 m diameter has a resistance of 1.75 Ω at 20° c. Calculate the value of the operating electric field along the wire when a steady current of 0.5 A is maintained in it.

Soln :

$$\text{We have } \rho = \frac{Rs}{\ell} = \frac{R\pi d^2}{4\ell}$$

(where d \rightarrow diameter)

$$\text{Then } \rho = \frac{\pi \times 1.75 \text{ ohm} \cdot (0.07)^2 \text{ m}^2}{4 \times 1.75 \text{ m}}$$

$$= 3.85 \times 10^{-3} \text{ ohm.m.}$$

$$\begin{aligned}\sigma &= \frac{1}{\rho} = \frac{1}{3.85 \times 10^{-3}} \text{ ohm}^{-1} \cdot \text{m}^{-1} \\ &= 260 \text{ mho} \cdot \text{m}^{-1}\end{aligned}$$

$$\text{Also } J = \frac{I}{s} = \frac{0.5 \text{ A}}{\pi(0.07 \text{ m})^2} = 129.9 \text{ A} \cdot \text{m}^{-2}$$

$$\begin{aligned}\text{Hence } \bar{E} &= \frac{\bar{J}}{\sigma} \\ &= \frac{129.9 \text{ A} \cdot \text{m}^{-2}}{260 \text{ mho} \cdot \text{m}^{-1}} \approx 0.5 \text{ volt} / \text{m}\end{aligned}$$

5.6 Variation of Resistance and Resistivity with temperature :

In eq. 5.5.3 resistivity ρ of metallic conductors has been given by

$$\rho = \frac{m}{e^2 n \tau}$$

This shows that ρ depends on the value of τ , the average time between two consecutive collisions of a free electron. When the conductor is heated the average kinetic energy of atoms increases and they vibrate more vigorously. This increases the number of collisions of the electrons with atoms. Hence τ decreases, there by increasing ρ . Since $R = \rho \frac{l}{s}$, resistance R of metallic conductors and many alloys like brass increases with rise of temperature θ . This has been verified experimentally.

However, in the case of semiconductors like Carbon, Germanium and Silicon and for many electrolytes R decreases with rise of θ .

Resistance is almost independent of temperature for some special type of alloys like constantan and Manganin.

Resistivity ρ of metallic conductors varies almost linearly with θ for moderate range of temperature. It is represented by the equation

$$\rho_{\theta} = \rho_0 + \rho_0 \alpha \theta = \rho_0 (1 + \alpha \theta) \quad \dots(5.6.1)$$

where ρ_{θ} is the resistivity of the metal at temp. θ°

ρ_0 is the resistivity at 0° and

α is a constant characteristic of the substance and is called the **temperature coefficient of resistivity**.

The defining equation for α i.e. eq. 5.6.1, is

$$\alpha = \frac{\rho_{\theta} - \rho_0}{\rho_0 \theta} \quad \dots(5.6.2)$$

We may thus define temperature coefficient of resistivity as the change in resistivity per unit resistivity at 0° , per degree rise in temperature.

Although eq. 5.6.2 is only approximate, it can be used over medium range of temperature except for very precise work. Its unit is dependent on the unit of temperature and is expressed as per kelvin (per K) or per celcius degree (i.e. per $^{\circ}\text{C}$) etc. One should note that θ in eq. 5.6.2 refers to a temperature interval like $\theta_2 - \theta_1$ but not any particular temperature. Its unit is given by per $^{\circ}\text{C}$ or per K etc.

At low and high temperatures ρ is expressed as some complicated function of θ and this is deliberately avoided at this stage.

Graphically the variation of ρ with θ over moderate temperature range is shown in fig. 5.11a.

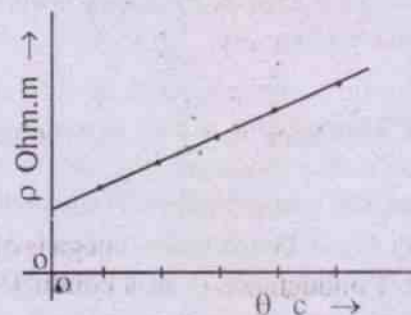

Fig. 5.11a

The resistance of a conductor depends on its length ℓ and area of cross section s besides its dependence on ρ . Changes in ℓ and s with temperature are quite negligible over moderate range of temperature so that ℓ/s may be taken as a constant. Hence variation of R with θ may be given by

$$R_{\theta} = R_0(1 + \alpha\theta) \quad \dots(5.6.3)$$

where R_{θ} and R_0 are resistances of the conductor at θ° and 0° respectively. The variation is linear as that for ρ . It is shown in fig. 5.11.b.

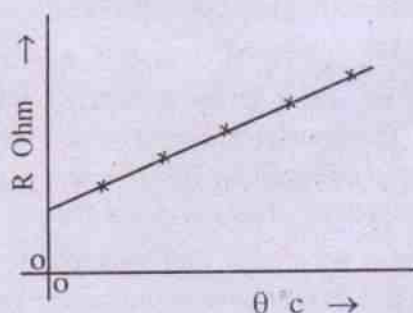

Fig. 5.11.b

The values of ρ and α of some typical materials at about 20°C are given Table 5.1.

The variation of R with θ has been used in the measurement of temperature. The thermometer so constructed is known as a resistance thermometer. Platinum resistance thermometer is an example of this type where resistance of platinum increases with rise of temperature.

Another thermometer of this type is called a **Thermistor**, which is made up of a semiconducting material like the oxides of nickel, cobalt, iron or copper. The property that the resistivity of a semiconductor decreases with rise of temperature is used in making a thermistor. It can measure very small changes in temperature of the order of 10^{-3}C° .

Table 5.1

Values of ρ and α of some materials at 293 K.

Material	ρ (Ohm-m)	α (K^{-1})
Aluminium	2.824×10^{-8}	3.9×10^{-3}
Copper	1.724×10^{-8}	3.93×10^{-3}
Gold	2.44×10^{-8}	3.4×10^{-3}
Iron	10×10^{-8}	5×10^{-3}
Metals: Mercury	95.87×10^{-8}	0.89×10^{-3}
Nickel	6.84×10^{-8}	6×10^{-3}
Platinum	10.6×10^{-8}	3.93×10^{-3}
Silver	1.59×10^{-8}	3.8×10^{-3}
Tungsten	5.65×10^{-8}	4.5×10^{-3}
Zinc	2.5×10^{-8}	-
Brass	6.7×10^{-7}	2×10^{-3}
Constantan	4.9×10^{-7}	2×10^{-6}
Alloys: Manganin	4.4×10^{-7}	2×10^{-6}
Nichrome	10×10^{-7}	4×10^{-3}
Semiconductors		
Carbon	3.5×10^{-5}	-0.5×10^{-3}
Germanium	0.46	-0.48×10^{-1}
Silicon	2300	-0.75×10^{-1}
Insulators		
Diamond	10^{11}	
Glass	$10^{10} \sim 10^{14}$	
Porcelain	$10^{10} \sim 10^{12}$	
Rubber	$10^{13} \sim 10^{16}$	
Teflon	10^{14}	
Wood	$10^8 \sim 10^{11}$	
Ceramics	10^{12}	
Paraffin wax	10^{20}	
Polythene	$10^{14} \sim 10^{16}$	

Ex. 5.6.1 A platinum resistance thermometer has a resistance of 18.265Ω at 0°C . Calculate the temperature when the resistance is measured to be 24.525Ω . The temperature coefficient of resistance of platinum is 0.00393 per $^\circ \text{C}$.

Soln.

$$\text{Given that } R_0 = 18.265 \Omega$$

$$R_\theta = 24.525 \Omega$$

$$\alpha = 0.00393 \text{ per } ^\circ \text{C}$$

$$\text{We have } \theta = \frac{R_\theta - R_0}{R_0 \alpha} \quad \text{from eq. 5.6.3}$$

$$\begin{aligned} \Rightarrow \theta &= \frac{(24.525 - 18.625) \text{ ohm}}{18.625 \text{ ohm} \times 0.00393 / ^\circ \text{C}} \\ &= 87.2 ^\circ \text{C} \end{aligned}$$

$$\begin{aligned} \therefore \text{Temperature recorded by the thermometer} &= \\ &= (0^\circ \text{C} + 87.2^\circ \text{C}) \\ &= 87.2^\circ \text{C} \end{aligned}$$

To be noted here is that in eq. 5.6.3 θ refers to the temperature interval only and is therefore expressed in $^\circ \text{C}$. This when added with the initial temperature gives the final temperature which is expressed in $^\circ \text{C}$.

5.7 Resistors

All conductors offer resistance of varying degrees to the flow of charges through them. These are known as **resistors**, and are of much importance and utility in electrical and electronic industries. Hence enough care is taken to manufacture such resistors with sufficient accuracy.

A good resistor should have the qualities like

- (i) Low temperature coefficient of resistivity

- (ii) Capacity to withstand high temperature
 - (iii) least change in resistance in the presence of moisture
- and
- (iv) high resistance to oxidation and corrosion.

Accordingly materials are selected to prepare good resistors.

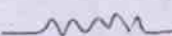
A resistor is represented by the symbol  in a circuit diagram. We may have either

- (i) wire wound resistors,
- (ii) composition resistors.

Wire wound resistors are made by winding wires of an alloy on some suitable base. Such alloys commonly used are

- (1) manganin (Cu 84%, Mn 12%, Ni 4%)
- (2) constantan (Cu 60%, Ni 40%)
- (3) nichrome (Ni 75%, Chromium 11%, Iron 12% and Mn 2%)

Most of the resistance boxes used in our laboratories are made up of such materials. One such resistor is a Rheostat which provides variable resistance. It is shown in Fig. 5.12. It consists of many turns of a wire wound on a metallic cylinder. The winding is normally of single layer. The electrical contact between adjacent windings is avoided by painting the wires with an insulating varnish which also protects them from moisture. Its circuit symbol is shown in fig. 5.12.b.

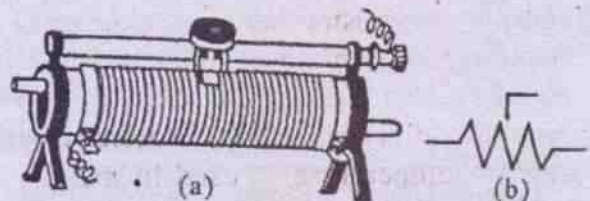

Fig. 5.12

Another type of variable resistor is a Resistance Box. A number of resistors having values of fixed resistance such as $1\ \Omega$, $2\ \Omega$, $5\ \Omega$ etc. are connected in series and the end of each resistor is soldered to the two ends of a metallic hole to which a metallic plug having insulating handle may exactly fit. The entire arrangement is kept inside a wooden case. The desired resistance is included in the circuit by opening the exact plug. A resistance box is shown in fig. 5.13.

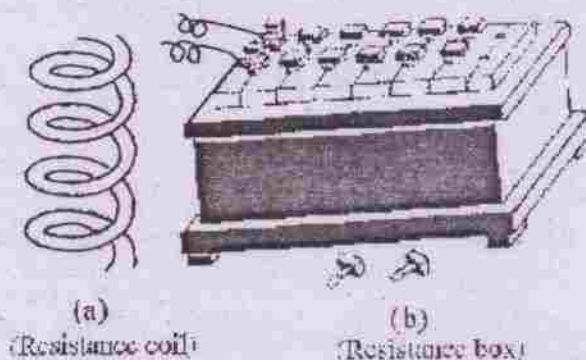

Fig. 5.13

Composition resistors are used in radio and communication circuits. Hence these are of compact size and low cost. These are made by mixing the powder of conducting material such as graphite with some suitable organic material which acts as binder and as a dielectric between the conducting particles. The mixture is then compressed and baked at a high temperature after which the conducting particles make contact among themselves. The resistance of it is controlled by using the dielectric binder and the conducting powder in different proportions.

As these resistors are of miniature size it is difficult to print the value of resistance on them. Hence **colour codes** are used to label the resistors. The colours used are **black, brown, red, orange, yellow, green, blue, violet, grey and white**. An assortment of such resistors is shown in fig. 5.14.



An assortment of resistors. The circular bands are color coding marks that identify the value of the resistance

Fig. 5.14

These resistors are commercially manufactured and range in value from an ohm to several mega ohms (i.e. $10^6\ \Omega$). The shapes of the resistors are cylindrical, their length being a few cm and diameter being a few mm. The resistors are identified with their colour codes, which serve to indicate their resistance and percentage of tolerance. The colours stand for some numbers varying from 0 to 9. Table 5.2 gives the value of colour codes for carbon resistance.

The following two conventions are used to know the resistance associated with a coded resistor.

(a) *Convention-I*

- (i) The body of the resistor is given one colour which denotes first significant figure.
- (ii) The colours on either end indicate the second significant figure.

Table 5.2

The numbers indicated by colour codes.

Colour →	Black	Brown	Red	Orange	Yellow	Green	Blue	Violet	Grey	White
Number they stand for →	0	1	2	3	4	5	6	7	8	9

- (iii) The coloured dot on the body indicates the number of zeroes at the end, and
- (iv) The ring of silver or gold at one end indicates the percentage of tolerance, **silver** for $\pm 10\%$ of tolerance and **gold** for $\pm 5\%$ of tolerance. This is diagrammatically shown in fig. 5.15 a.

For example we have a resistor with **orange body, yellow ends, red dot and gold ring**, using the numbers represented by these colours we find that its resistance $R = 3400 \pm 5\%$ ohms.

(b) *Convention II*

In this convention there are three rings or bands marked at one end of the resistor and a ring of silver or gold at the other end.

- (i) The first two rings in order stand for the first two significant figures.
- (ii) The third ring stands for the number of zeroes at the end i.e. the power of 10.
- (iii) The gold or silver ring indicates the percentage of tolerance.

This is diagrammatically shown in fig. 5.15.b. For example we have a commercial carbon resistor with **green, yellow and orange rings** at one end and a **ring of silver** at the other end. Then using Table 5.2 we have the resistance R represented by the resistor $= 54 \times 10^3 \pm 10\%$

i.e. $R = 54000 \pm 10\%$ ohm

Usually high resistances in miniature form are used in electronic and radio circuits as per necessity. However, for precise work it is better to avoid such resistors as the errors vary from 5% to 10%.

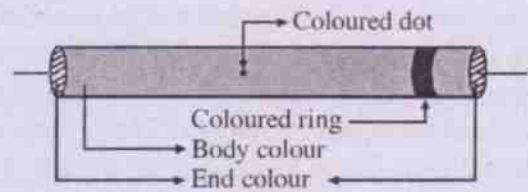

coded resistor as per convention I

Fig. 5.15.a

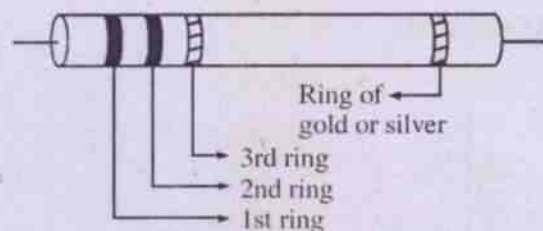

coded resistor as per convention II

Fig. 5.15.b

However, composition resistors are not as precise as wire wound resistors, as their resistances may change with change in surrounding conditions, such as the presence of humidity and change in applied voltage etc.

Resistors of better stability are obtained by depositing films of carbon, boron-carbon, metals or metal oxides on some convenient ceramic base. Such resistors are called film resistors. Their resistance is fairly constant in time and these are comparatively insensitive to applied voltage. The temperature coefficient of resistance of these resistors is low too.

Super Conductivity

Super conductivity is the property attained by conductors at a very low temperature nearer to absolute zero. The resistivity of the material then decreases to zero, so that charge flow can occur through them without any thermal energy loss. Hence currents created in a superconducting ring can persist in it for years without any decrease or loss in its value.

The phenomenon was first discovered by H. Kamerlingh Onnes in 1911. Experimentally

he could observe that the resistivity of mercury was almost zero at about 4.2 K. Further investigations revealed that almost all conductors lose their resistivity at temperatures nearer to absolute zero. Such a temperature at which a material attains superconductivity is called its **critical temperature** T_c . Graphically it is shown in fig. 5.16 a. In contrast this variation for metals and semiconductors is shown in fig 5.14 (b) and (c).

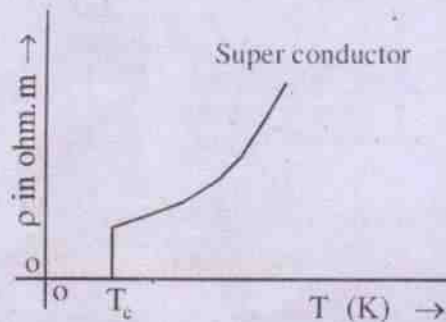

(a)

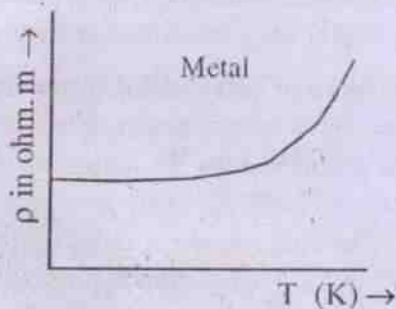

(b)

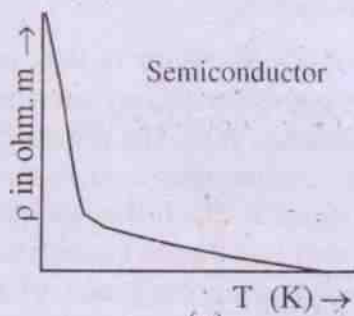

(c)

Fig. 5.16

Superconductors are of much importance in the

modern world when saving of energy is highly essential. Superconducting loops can maintain steady current for years together without any loss of energy and strong magnetic field can be created in a region using them. This has useful applications in material science research and high energy particle physics. Superconductors can play a very important role in making ultrafast computer switches and transmission of electric power. But the difficulty lies in the attainment of desired low temperatures which becomes a costly affair at present. However, new ceramic materials have been discovered in 1986 which behave as super conductor at considerable higher temperatures nearer to 125K. Extensive researches are in progress to prepare compounds which would be superconducting even at room temperature.

Explanation of this unique property of materials has been possible to a great extent using quantum mechanical calculations. This is beyond the scope of this book at this stage.

Worked out numerical examples

Example 5.1 : A current of 5A exists in a 10 ohm resistor for 4 min. Calculate (a) the amount of charge and (b) the number of electrons that pass through any cross section of the resistor in this time.

Solution :

$$\text{Given } I = 5A$$

$$t = 4 \text{ min} = 240 \text{ s}$$

$$(a) \therefore q = I t = 5A \times 240 \text{ s} = 1200 \text{ coul.}$$

$$(b) \text{ No. of electrons} = \frac{q}{e} = \frac{1200C}{1.6 \times 10^{-19}C} \\ = 750 \times 10^{19} = 75 \times 10^{20}$$

Example 5.2 : A current is established in a gas discharge tube when a sufficiently high potential difference is applied across the two electrodes in the tube. The gas ionizes, electrons move towards the +ve terminal and +ve ions towards

the -ve terminal. Calculate the magnitude of electric current in such a discharge tube of hydrogen in which 3.1×10^{18} electrons and 1.1×10^{18} protons move past a cross sectional area of the tube each second. Find the sense of current.

Solution :

No. of electrons moving past a section, say, from left to right = 3.1×10^{18} per sec.

Equivalent (+ve) charge flow from right to left = $3.1 \times 10^{18} \times 1.6 \times 10^{-19}$ C/sec.

$$\begin{aligned} \text{i.e. } I_1 &= 4.96 \times 10^{-1} \text{ A} \\ &= 0.496 \text{ A} \end{aligned}$$

No. of protons moving from right to left

$$= 1.1 \times 10^{18} \text{ per sec.}$$

\therefore Equivalent charge flow from right to left

$$= 1.1 \times 10^{18} \times 1.6 \times 10^{-19} \text{ C sec.}$$

$$= 1.76 \times 10^{-1} \text{ A i.e. } I_2$$

$$= 0.176 \text{ A}$$

\therefore Magnitude of electric current

$$\begin{aligned} I &= I_1 + I_2 \\ &= 0.496 \text{ A} + 0.176 \text{ A} \\ &= 0.672 \text{ A} \approx 0.67 \text{ A} \\ &\text{in the sense from right to left} \end{aligned}$$

Example 5.3 : A current of 1 A exists in a copper wire of cross section 1 mm^2 . Calculate the drift speed of the free electrons in the wire. Density of copper = 9000 kg/m^3 . Molecular mass of copper = 63.5 g mol^{-1} .

Solution :

$$1 \text{ g-mole of cu.} = 63.5 \text{ g of cu.}$$

\therefore 63.5 g of cu. contains 6.023×10^{23} no. of free electrons.

\therefore 1 kg of cu. contains $\frac{6.023}{63.5} \times 10^3 \times 10^{23}$ no. of free electrons.

\therefore 9000 kg of cu. contains $\frac{6.023 \times 9}{63.5} \times 10^{29}$ no. of free electrons.

\therefore n = no. density of free electrons in cu.
 $= \frac{6.023 \times 9 \times 10^{29}}{63.5} \text{ per m}^3$

$$J = \frac{I}{s} = \frac{1 \text{ A}}{1 \text{ mm}^2} = \frac{1 \text{ A}}{10^{-6} \text{ m}^2} = 10^6 \text{ A/m}^2$$

$$\therefore v_d = \frac{J}{ne} = \frac{10^6 \text{ A/m}^2}{\frac{6.023 \times 9 \times 10^{29}}{63.5} \cdot \frac{1}{\text{m}^3} \times 1.6 \times 10^{-19} \text{ C}}$$

$$= \frac{63.5 \times 10^6 \text{ Am}^3}{6.023 \times 14.4 \times 10^{10} \text{ Cm}^2}$$

$$= 0.732 \times 10^{-4} \text{ m/S}$$

$$= 0.0732 \text{ mm/S}$$

Example 5.4 : A wire of length 1 m and radius 0.1 mm has a resistance of 100Ω . Find the resistivity of the material.

Solution :

$$\text{Given } l = 1 \text{ m}$$

$$r = 0.1 \text{ mm} = 10^{-4} \text{ m}$$

$$\therefore s = \pi r^2 = \frac{22}{7} \times 10^{-8} \text{ m}^2$$

$$R = 100 \Omega$$

$$\therefore R = \frac{\rho l}{s}$$

$$\begin{aligned}\therefore \rho &= \frac{Rs}{\ell} = \frac{100\Omega \times \frac{22}{7} \times 10^{-8} \text{ m}^2}{1\text{m}} \\ &= \frac{22}{7} \times 10^{-6} \Omega \cdot \text{m} \\ &= 3.143 \times 10^{-6} \Omega \cdot \text{m}\end{aligned}$$

Example 5.5 : Calculate the electric field in a copper wire of cross sectional area 2 mm^2 if the current in it is 1 A . Resistivity of $\text{Cu} = 1.7 \times 10^{-8} \Omega \cdot \text{m}$.

Solution :

$$\text{Given } s = 2 \text{ mm}^2 = 2 \times 10^{-6} \text{ m}^2$$

$$I = 1 \text{ A},$$

$$\rho = 1.7 \times 10^{-8} \Omega \cdot \text{m}$$

$$\therefore J = I/s = \frac{1}{2 \times 10^{-6}} \text{ A/m}^2$$

$$\therefore J = \sigma E, \text{ we have } E = \frac{J}{\sigma} = \rho J$$

$$\begin{aligned}\therefore E &= 1.7 \times 10^{-8} \Omega \cdot \text{m} \times \frac{1}{2 \times 10^{-6}} \text{ A/m}^2 \\ &= 0.85 \times 10^{-2} \frac{\Omega \cdot \text{A}}{\text{m}} \\ &= 0.85 \times 10^{-2} \frac{\text{V}}{\text{m}}\end{aligned}$$

Example 5.6 : The resistivity of tungsten at $20^\circ \text{C} = 5.65 \times 10^{-8} \Omega \cdot \text{m}$. If the temperature coefficient of resistivity of tungsten is $4.5 \times 10^{-3} \text{ K}^{-1}$, find its resistivity at 400 K .

Solution :

$$\text{Given } \rho_{20^\circ \text{C}} = 5.6 \times 10^{-8} \Omega \cdot \text{m}^{-1}$$

$$\text{i.e. } \rho_{293\text{K}} = 5.6 \times 10^{-8} \Omega \cdot \text{m}$$

$$\alpha = 4.5 \times 10^{-3} \text{ K}^{-1}$$

$$\therefore \rho_{400\text{K}} = \rho_{293\text{K}} [1 + \alpha(400 - 293)\text{K}]$$

$$= 5.6 \times 10^{-8} \Omega \cdot \text{m} [1 + 4.5 \times 10^{-3} \text{ K}^{-1} \times 107\text{K}]$$

$$= 5.6 \times 1.4815 \times 10^{-8} \Omega \cdot \text{m}$$

$$= 8.3 \times 10^{-8} \Omega \cdot \text{m}$$

Example 5.7 : Find the temperature at which the resistance of a silver wire will be double its value at 293 K . $\alpha_{\text{silver}} = 3.8 \times 10^{-3} \text{ K}^{-1}$.

Solution :

Let R_0 be the resistance at 293° K i.e. at T_0 and $R = 2R_0$ be the resistance at $T \text{ K}$.

$$\text{Then } R = R_0 [1 + \alpha(T - T_0)]$$

$$\Rightarrow 2R_0 = R_0 [1 + \alpha(T - 293 \text{ K})]$$

$$\Rightarrow 1 = \alpha(T - 293 \text{ K})$$

$$= 3.8 \times 10^{-3} \text{ K}^{-1} (T - 293 \text{ K})$$

$$\Rightarrow 1 + 3.8 \times 10^{-3} \text{ K}^{-1} \times 293 \text{ K} = 3.8 \times 10^{-3} \text{ TK}^{-1}$$

$$\Rightarrow 1 + 1.1134 = 3.8 \times 10^{-3} \text{ K}^{-1} \cdot T$$

$$\Rightarrow \frac{2.1134}{3.8 \times 10^{-3}} \text{ K} = T$$

$$\Rightarrow T = 0.556 \times 10^3 \text{ K} = 556 \text{ K}$$

SUMMARY

1. Electric current is the rate of flow of net charge across any section of a conductor. It is given by

$$I = q/t \text{ (for uniform rate of flow)}$$

$$I = \frac{dq}{dt} \text{ (for instantaneous rate of flow)}$$

2. The conventional direction of current is the direction in which a positive charge would flow through the conductor.

3. Electrons flow in a direction opposite to that of conventional current.

4. Electric current, I , is a scalar.

5. S.I. unit of I is Ampere (A)
 $1A = 1 C/s$ where C stands for coulomb.
6. The vector associated with electric current is called current density \vec{J} .
7. Current through any section of area s of a conductor is given by

$$I = \int_0^s \vec{J} \cdot d\vec{s}$$

For uniform value of J over the entire section of the conductor

$$I = J s$$

$$\Rightarrow J = I / s$$

Hence current density may be loosely defined as the current through unit area of cross section of the conductor.

8. Drift velocity \vec{v}_d of charge carriers is defined as the final average velocity with which the charge carriers move under the influence of the external electric field established in a conductor. It is of the order of a few mm/s.
9. Current density in terms of drift velocity is given by

$$\vec{J} = ne\vec{v}_d$$

where ne is the carrier charge density.

10. Current in terms of drift speed in a straight conductor of section s is given by

$$I = nsev_d$$

11. Current density is related to applied electric field \vec{E} by

$$\vec{J} = \sigma\vec{E}$$

where σ is called the conductivity of the material of the conductor.

12. **Ohm's law** is stated as

"Temperature and other physical conditions remaining the same, the current I in

a conductor is directly proportional to the potential difference V across its ends." Mathematically

$$I \propto V \Rightarrow I = G V$$

where G is called the conductance of the conductor.

13. Resistance R of a conductor is given by

$$R = V / I = \frac{1}{G}$$

Unit of R is Ohm (Ω) in S.I. system. $1\Omega = \frac{1V}{1A}$

Unit of G is mho in S.I. system.

14. Resistivity ρ is an electrical property of the material of the conductor.

$$\rho = \frac{1}{\sigma} = \frac{E}{J} \quad \text{Vectorically } \vec{E} = \rho\vec{J}$$

S.I. unit of resistivity is ohm-metre ($\Omega \cdot m$)

S.I. unit of conductivity is mho/metre.

15. The resistance R of a conductor of length ' l ' and area of cross section ' s ' is given by

$$R = \rho \frac{l}{s}$$

where ρ is the resistivity of its material.

ρ changes with temperature T . For many materials, including metals the relation between ρ and T is given by

$$\rho = \rho_0 [1 + \alpha(T - T_0)]$$

where ρ_0 is the resistivity of the material at a reference temperature T_0 .

17. A given conductor obeys Ohm's law if its resistance $R = \frac{V}{I}$, is independent of the applied potential difference V and if its resistivity is independent the magnitude and direction of the applied electric field \vec{E} .

18. Resistance is the macroscopic electrical property of a conductor. It is dependent on the

microscopic property ρ i.e. the resistivity of the material.

19. $\rho = \frac{m}{e^2 n \tau}$ where n is the no. of electrons

per unit volume and τ is the mean time between the collisions of an electron with the atoms of the metallic conductor. τ is independent of \vec{E} .

20. Semiconductors are a group of materials placed between conductors and insulators. These have negative temperature coefficient of resistivity.

21. Super conductors are materials that lose electrical resistance at low temperatures i.e. below a temperature called critical temperature T_c which is dependent on the nature of the material.

MODEL QUESTIONS

A. Multiple Choice Questions :

1. A metallic resistor is connected across a battery. If the number of collisions of the free electrons with the lattices is decreased by cooling it, the current in the circuit will
 - (a) remain constant.
 - (b) decrease.
 - (c) increase.
 - (d) become zero.
2. When temperature of a metallic resistor is increased the product of its resistivity and conductivity
 - (a) decreases.
 - (b) remains constant.
 - (c) increases.
 - (d) may increase or decrease.
3. A copper wire is connected across a battery. The current in the wire is found to be 0.5 A when the key is closed. The no. of free electrons that flow through any section of the wire in 10 s is nearly
 - (a) 3125×10^{16} .
 - (b) 312.5×10^{16} .
 - (c) 31.25×10^{16} .
 - (d) 3.125×10^{16} .
4. A current of 2A is established in a circuit containing an aluminium resistor of length 30 cm. If the area of cross section of the resistor is 0.003 cm^2 at a point P, the current density at the point is
 - (a) $6.67 \times 10^6 \text{ A/m}^2$.
 - (b) $6.67 \times 10^6 \text{ A.m}^2$.
 - (c) $6.67 \times 10^7 \text{ A/m}^2$.
 - (d) $6.67 \times 10^7 \text{ A.m}^2$.
5. The drift speed of charge carriers in a conductor, connected between the terminals of battery is v_d when it carries a current I. If the length of the conductor is reduced by half, the drift speed of the charge carriers at a given point in it
 - (a) is doubled.
 - (b) remains the same.
 - (c) is reduced by half.
 - (d) decreases $\sqrt{2}$ times.
6. A steady current is maintained in a linear conductor having nonuniform cross section. The quantity of charge flowing per second is
 - (a) more at the thinner point than at the thicker point.
 - (b) more at the thicker point than at the thinner point.
 - (c) independent of its length and area of cross section at any point
 - (d) independent of the area of cross section at any point but depends on its length.
7. A metallic conductor is cut into four equal parts. The resistivity of each part
 - (a) increases four times with increase in resistance.
 - (b) becomes one fourth with decrease in resistance.
 - (c) does not change with change in its resistance.
 - (d) does not change without any change in its resistance.
8. Holes are charge carriers in
 - (a) gas discharge tubes.
 - (b) p-type germanium.
 - (c) tungsten.
 - (d) copper sulphate solution.

9. A current density of 10^{-12} Am^{-2} carries charges from the surface of the earth to a region spreading over 50 km above the surface. If the electric field in the region is 100 Vm^{-1} the electrical conductivity of the earth is of the order of
- 10^{-14} ohm-m .
 - $10^{-10} \text{ ohm m}^{-1}$.
 - $10^{-14} \text{ ohm}^{-1} \text{ m}^{-1}$.
 - $10^{-10} \text{ ohm}^{-1} \text{ m}$.
10. The current in electrolyte is due to
- positive ions only.
 - negative ions only.
 - both positive and negative ions.
 - holes.
11. The electric current density is a measure of the current per unit
- volume. (b) area.
 - length. (d) time.
12. Increasing the potential difference between the ends of a conductor, results in
- increasing the current only.
 - increasing the current and decreasing the resistance.
 - increasing the resistance only.
 - increasing the resistance and decreasing the current.
13. The dimension of conductance is
- $\text{M}^1 \text{L}^2 \text{T}^{-3} \text{A}^{-2}$.
 - $\text{M}^{-1} \text{L}^{-2} \text{T}^3 \text{A}^2$.
 - $\text{M}^{-1} \text{L}^{-3} \text{T}^3 \text{A}^2$.
 - $\text{M}^1 \text{L}^3 \text{T}^{-3} \text{A}^{-1}$.
14. The length of a manganin wire of diameter 0.07 cm is 1.75 m at 20°C . If the resistivity of manganin is $44 \times 10^{-6} \text{ ohm-cm}$, its resistance is
- 2 ohm (b) 3 ohm
 - 4 ohm (d) 4.4 ohm
15. A silver wire has a resistance of 2 ohm at 100°C . If the temperature coefficient of resistance of silver is 0.00375 per $^\circ \text{C}$, its resistance at 200°C will be nearly
- 4 ohm. (b) 3.75 ohm.
 - 2.54 ohm. (d) 2 ohm.
16. Two cylindrical wires of the same material have their lengths in the ratio 2:1 and their diameters in the ratio 1:2. The ratio of the resistance of thinner wire to that of thicker wire is
- 1 : 8. (b) 1 : 4.
 - 4 : 1. (d) 8 : 1.
17. The temperature coefficient of resistance is nearly zero for
- copper. (b) silicon.
 - silver. (d) manganin.
18. Which of the following equations is wrong ? (the symbols have their usual meaning)
- $\vec{J} = \sigma \vec{E}$. (b) $I = G V$.
 - $I = \frac{\sigma E}{A}$. (d) $I = \sigma EA$.
19. The dimension of electric potential difference is
- $\text{M}^1 \text{L}^2 \text{T}^{-3} \text{A}^{-1}$.
 - $\text{M}^1 \text{L}^2 \text{T}^{-2} \text{A}^{-1}$.
 - $\text{M}^2 \text{L} \text{T}^{-3} \text{A}^{-1}$.
 - $\text{M}^2 \text{L}^2 \text{T}^{-3} \text{A}^{-1}$.

20. Critical temperature of a material is that temperature below which a conductor behaves as
- an insulator.
 - a semiconductor.
 - a super conductor.
 - a thermistor.
- B. Very Short Answer Type Questions :**
- Define one 'ampere' and one 'ohm'
 - Name another physical quantity like current that is a scalar having a sense represented by an arrow in a diagram.
 - Mention the dimension of electric current.
 - Which direction is taken as the conventional direction of current ?
 - Define current density.
 - Is there any change in the resistivity of a metal if a wire made of it is cut into pieces ?
 - Correct the equation $\text{volt} = \frac{\text{ampere}}{\text{ohm}}$.
(CHSE 1985 A)
 - What happens to the current in a conductor when a very high resistance is connected across it ?
 - Does a fuse wire have high melting point ?
 - If the thickness of a wire increases what happens to its resistance ?(CHSE 1985 S)
 - Mention the unit of conductance.
(CHSE 1986 S)
 - Give the unit of electrical conductivity.
(CHSE 1987 S)
 - Does the relation $V = I R$ apply to non ohmic resistors ?
 - What happens to electrical resistance of carbon when it is heated ?(CHSE 1995 S)
 - Give the relation between current and current density vector. (CHSE 1994 A)
 - Does a conductor become charged when it carries a current ?
 - We often say "a current is flowing through a wire". What exactly flows, the charge or the current ?
 - Out of two bulbs marked 220V, 25W and 220V, 100W, which has the higher resistance ? [CBSE 2003]
 - Which physical quantity represents the slope of voltage versus current graph of a metallic conductor ? [CBSE AI 2000C]
 - Why manganin is used for making standard resistors ? [CBSE 1995]
 - How does the drift velocity of electrons in a metallic conductor change if the length of the conductor is doubled by stretching it, keeping the applied potential difference constant ?
[CBSE 2002, CBSE AI 1997 C]
 - What is the effect of heating of a conductor on the drift velocity of free electrons ? [CBSE Sample Paper]
- C. Short Answer Type Questions :**
- Distinguish between resistance and resistivity.
 - Can a copper wire and an aluminium wire of the same length and same diameter have the same resistance ? Why ?
 - Define temperature coefficient of electrical resistance.
 - A wire of length ℓ and radius r is connected to a voltage V . How is the drift velocity of charges affected if (a) ℓ is doubled, (b) r is doubled ?
 - Two copper wires having the same length but different cross sectional area are connected to the same battery. How does the current densities in them compare ?

6. Discuss the variation of resistivity with temperature.
7. Explain the meaning of resistance of a conductor.
8. What happens when two initially charged conducting bodies are connected by a wire?
9. Plot a curve to show the variation of the ammeter reading in the figure given below, as a function of rheostat resistance. Interpret the shape and intercepts of this curve.

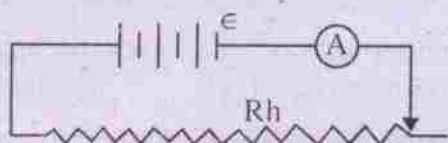

10. From the definition of quantity of electricity in terms of current show that $It = vq$, where v is the speed of charges flowing through the conductor of length l .
11. Find the resistivity of a wire of length 25.4 cm and diameter 0.932 mm if its resistance is 0.067 ohm at a temperature of 20°C . (CHSE 1986 S)
12. Explain the origin of electrical resistance in a conductor. (CHSE 1989 S)
13. Explain why metals are good conductors of electricity. (CHSE 1987 S)
14. Define resistivity of a material. Mention its unit in S.I. system.
15. How many electrons pass in 16 sec through the cross section of a metal wire carrying a current of 100 mA? ($e = 1.6 \times 10^{-19}\text{ C}$) (CHSE 1992 A)
16. Define the term resistivity and write the S.I. unit. [CBSE 2005]
17. Define electrical conductivity of conductor and give its S.I. unit. [CBSE 2008, 05, 03]
18. If potential difference applied across a conductor is increased from V to $2V$, how the drift velocity of the electron change? [CBSE AI 2000 C]

19. The metallic conductor is at temperature θ_1 . The temperature of metallic conductor is increased to θ_2 . How will the product of its resistivity and conductivity change? [CBSE 2002 C]
20. Write an expression for the resistivity of a metallic conductor showing its variation over a limited range of temperature.

[CBSE 2008 C]

D. Long Answer Type Questions :

1. Explain the meaning of drift velocity of electrons. Find an expression for current in a conductor in terms of it.
 2. State and explain Ohm's law. Deduce it mathematically. Distinguish between ohmic and non ohmic resistance.
 3. Deduce the relation $\vec{J} = \sigma \vec{E}$ from first principles considering Ohm's law to be true.
 4. Discuss the different factors on which the resistance of a conductor depends. How does a semiconductor differ from a conductor?
 5. Show that current density \vec{J} is related to electric field \vec{E} by the equation $\vec{J} = \frac{ne^2\tau}{m} \vec{E}$ where the symbols have their usual meaning.
 6. Discuss the variation of resistance with temperature. Mention two important applications of the phenomenon.
- E. Numerical Exercises :**
1. Find the number of electrons that pass through a lamp in one hour if a steady current of 0.5 A is maintained in it during the time.
 2. A 12.5 V battery operates a $14.2\ \Omega$ flash light intermittently for a cumulative time of 65.3 minutes. Calculate the average current and the quantity of electricity furnished by the battery.
 3. Find the number of free electrons in a copper wire of length 1m and cross

- sectional area 1 mm^2 . Determine the charge carried by these free electrons. Number density of free electrons in copper is 8.5×10^{28} per m^3 .
- A silver wire of cross section 1 mm^2 carries a current of 2 A. Find the magnitude of current density in the wire.
 - Find the total charge carried by the number of free electrons in a copper wire of length 1m and cross section 1.6 mm^2 if density of copper is $9 \times 10^3 \text{ kg/m}^3$ and its molecular mass 63.5 g mole^{-1} . Assume valency of copper to be one.
 - A copper wire of radius 0.1 mm and resistance $1 \text{ k}\Omega$ is connected across a power supply of 20 V. (a) How many electrons are transferred per sec. between the supply and the wire at one end? (b) Find the current density of the wire.
 - A wire of 2mm in diameter transfers a charge of 60 coul. in 5 minutes. If the number density of electrons in the wire is 5.8×10^{28} per m^3 , calculate
 - the current in the wire;
 - the drift speed of electrons in the wire.
 - A copper wire of circular cross section has a radius of 1mm. It carries a current of 0.5 A. If the resistivity of copper at room temperature is $1.724 \times 10^{-8} \Omega \cdot \text{m}$, find the magnitude of current density in the wire and that of electric field intensity in it.
 - The conductivity of aluminium is $3.55 \times 10^7 \text{ ohm}^{-1} \cdot \text{m}^{-1}$ at room temperature. Find the resistance of an aluminium wire of length 1m and diameter 2mm.
 - Two wires of aluminium and copper have the same length and same resistance. Show by calculation which of them is lighter. Densities of copper and aluminium are $8.9 \times 10^3 \text{ kg/m}^3$ and $2.7 \times 10^3 \text{ kg/m}^3$ respectively. $\rho_{\text{Cu}} = 1.724 \times 10^{-8} \Omega \cdot \text{m}$ and $\rho_{\text{Al}} = 2.824 \times 10^{-8} \Omega \cdot \text{m}$
 - Determine the resistance of a silver wire through which 360 coul. of charge flows in 2 minutes under a potential difference of 30 V between its ends.
 - A wire of diameter 1mm has a resistance of 14 ohm. If the resistivity of its material is $44 \times 10^{-6} \Omega \cdot \text{cm}$, calculate its length.
 - (a) The current density in a cylindrical wire of radius $R = 2 \text{ mm}$ is uniform over the cross section of the wire and is given by $J = 2 \times 10^4 \text{ A/m}^2$. Find the current through the outer portion of the wire between the radial distance $R/2$ and R .
 - If $J = f(r)$ and is given by $J = br^2$ where $b = 3 \times 10^{10} \frac{\text{A}}{\text{m}^2}$ and r is any radial distance in metres, find the current through the given portion as in (a).
 - The copper windings of a motor have a resistance of 50Ω at 20°C , when the motor is idle. After running for several hours, the resistance rises to 58Ω . Calculate the temperature of the windings at the end. $\alpha_{\text{Cu}} = 3.93 \times 10^{-3} \text{ K}^{-1}$.
 - A wire with a resistance of 6Ω is drawn out so that its new length is thrice its original length. Find the resistance of the longer wire assuming that the resistivity and density of the material do not change during the process.
 - Find the resistance of 0.5 kg copper wire of diameter 0.008 m. Given that the density of copper = $8.9 \times 10^3 \text{ kg/m}^3$ and use its value of resistivity from Table 5.1.
 - A battery connected to a rheostat furnishes certain current. When a lamp of resistance 150Ω is inserted in series, the current is reduced to one third of its former value. Find the resistance of the rheostat.

18. An electric lamp has a filament diameter of 0.525 mm. For 2.84 ampere of current in the lamp, 1.37×10^{22} electrons/ml are found to flow through the wire. Calculate the average speed of the electrons in it.
19. A cylindrical metallic wire is stretched to increase its length by 10%. Calculate the percentage increase in resistance.
[CBSE 2007]
20. What is the change in resistance of an Eureka wire when its radius is halved and the length is reduced to one-fourth of its original value. [CBSE Sample Paper]
- F. True - False - Type Questions**
1. An ordinary 100W lamp has more resistance than a 60W lamp.
 2. The Kilowatt - hr is a unit of energy.
 3. The electric current density is a measure of current per unit area.
 4. Holes are charge carriers in p-type germanium.
 5. When the temperature of a metallic conductor increases its resistance decreases.
 6. Ohm's law is applicable to all conductors of electricity.
 7. The resistance of an incandescent lamp is greater when the lamp is switched on.
- G. Fill - in - Blank Type Questions**
1. Increasing the P.D. between the ends of a conductor results in.....
 2. Two identical metal wires have their lengths in ratio 2 : 3. Their resistance shall be in the ratio.....
 3. Temperature coefficient of resistance is nearly zero for.....
 4. The dimension of electric potential difference is
 5. The relation between current density (\vec{j}), conductivity (σ) and electric field strength \vec{E} is
 6. The resistance of a copper wire varies directly as and inversely as.....
 7. The expression for conductivity (σ) is
- H. Correct the following sentences :**
1. The resistance of a metallic conductor decreases with rise in temperature.
 2. Holes are charge carriers in n-type germanium.
 3. Volt = Ampere/ohm.
 4. Electric current is a vector quantity.
 5. The relation between current density \vec{j} , conductivity σ , and electric field \vec{E} is $\vec{E} = \sigma \vec{j}$.
 6. Dimension of electric potential difference is $M L^2 T^3 A^{-1}$.
 7. Two copper wires have their radii in the ratio 2:3. Their resistance shall be in the ratio 4:9.

ANSWERS

A. Multiple Choice Type Questions :

1. (c) 2. (b) 3. (a) 4. (a) 5. (a) 6. (d) 7. (c) 8. (b)
 9. (c) 10. (c) 11. (b) 12. (a) 13. (b) 14. (a) 15. (c) 16. (d)
 17. (d) 18. (c) 19. (a) 20. (c)

E. Numerical Problems :

1. 1.125×10^{22} .
2. a. 0.88 A, b. 3449 C.
3. 8.5×10^{22} , 1.36×10^4 C.
4. 2×10^6 A/m².
5. 2.1854×10^4 C.
6. 1.25×10^{17} , 6.37×10^5 A/m².
7. 0.2 A, 6.86×10^{-3} mm/s.
8. 1.59×10^5 A/m², 2.74×10^{-3} V/m.
9. 0.00897 Ω .
10. $M_{Al} / M_{cu} = 0.497$, Hence Aluminium wire is lighter.
11. 10 Ω .
12. 25 m.
13. a) 0.19 A b) 0.71 A.
14. 60.7 °C.
15. 54 Ω .
16. 3.83×10^{-14} \rightarrow
17. 75 Ω .
18. 6×10^{-3} m/s.
19. 21%
20. No change.

- F. (1) False (because $R = \frac{V^2}{P}$, so a lamp with higher power will have less resistance) (2) True
 (3) True (4) True (5) False (6) False (7) True.

- G. (1) Increasing the current only (2) 2 : 3 (3) Manganin (4) $ML^2 T^{-3} A^{-1}$ (5) $\sigma \vec{E}$ (6) I, A

6

Direct Current Circuits

Electric circuit in which the sense of charge flow does not change with time, is called direct current circuit or d.c. circuit. A simple d.c. circuit contains components like a source of emf, a resistor and a switch / key as discussed earlier. Sometimes the number of such sources and resistors may be many giving rise to a complicated network. Simple application of Ohm's law may not be sufficient to analyse such circuits. Hence alternative procedures are needed. A discussion on this and about the sources of emf will be the subject matter of this chapter. In all our discussions we shall be concerned with steady currents where the magnitude and sense of current remain constant with time. We begin with an insight into the concept of electromotive force (emf) and its sources.

6.1 Electromotive force :

Let us call a conductor with some resistance as a resistor. Electric current in a resistor R occurs under a potential difference between its ends. A steady current needs a steady potential difference. However, current cannot be steady unless its path is closed and contains another device called a source of emf \mathcal{E} at some point in the path. Such a closed path is shown in fig. 6.1. Here the current I in the

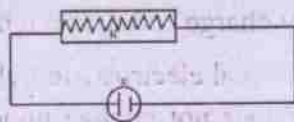

Fig. 6.1

(A closed electric circuit containing a source of emf and resistor)

resistor R requires an electric field \vec{E} within it and an associated potential. The field does positive work on the mobile charges (assumed to be +ve) which always move in the direction of decreasing potential. In a complete trip around the loop, the charge returns to its starting point so that the potential must be the same as that when it left the point. This is not possible if the motion around the loop involves decrease of potential only. There must be some portion of the loop where the charge is pushed from lower to higher potential. This portion contains the source of emf which does the job.

"The influence of the source to make the charges move from lower to higher potential is called the electromotive force or emf."

The name emf is a misnomer since it is not a force. Every complete circuit in which there is a steady current, contains the device that provides steady emf. Chemical cells, generators, photocells, thermocouples etc. are some examples of such devices. Let us call them as the sources of emf. A source of emf transfers energy into the circuit to which it is connected.

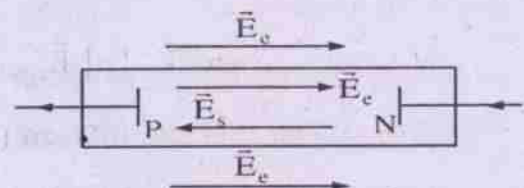

(Schematic diagram of a source of emf, an open circuit)

Fig. 6.2

Fig. 6.2 is a schematic diagram of a source of emf. It has two conducting terminals P and N where +ve and -ve charges are stored in some process. Thus a potential difference is maintained between them. If there is no resistor connected between P and N externally it is called an **open circuit**. Some force within the source pushes the +ve charges to be deposited at P and the -ve charges at N. Let us call such a force per unit charge as the **source force** \vec{E}_s . It is of **nonelectrostatic origin**. We may call it the nonelectrostatic field \vec{E}_s .

As the charges at the terminals P and N pile up an electrostatic field \vec{E}_e both inside and outside the source builds up gradually. This field \vec{E}_e is in opposition to \vec{E}_s within the source and slows down the process of accumulation of the positive charges at P. Within a short time, \vec{E}_e equals \vec{E}_s so that equilibrium is established and the process of charge accumulation stops.

Thus in open circuit condition $\vec{E}_s + \vec{E}_e = 0$. Then a potential difference V_{PN} exists between the terminals P and N. It is equal to the work done per unit charge when a charge moves from P to N by the electrostatic field \vec{E}_e . V_{PN} is called the **Terminal Potential Difference (T.P.D.)**

In a similar way we may consider the work done by the nonelectrostatic field \vec{E}_s (i.e. the source field). The work done by this source field to make a charge move from N to P is called the electromotive force ϵ of the source.

Under open circuit condition $|\vec{E}_s| = |\vec{E}_e|$ and

$$V_{PN} = \epsilon \quad \dots(6.1.1)$$

Thus we see that electromotive force is not a force. It is the work done per unit charge by a field which is of nonelectrostatic origin. It

involves the process of energy conversion from nonelectrical to electrical.

The **nonelectrostatic field** \vec{E}_s and hence the **emf** ϵ of the source are constants in many cases. It represents a definite property of the source.

If the terminals of the source are connected by a wire to form a complete circuit, the driving force on the free charges in the wire is due to the field set up by the charged terminals P and N. It establishes a current I in the wire from P to N.

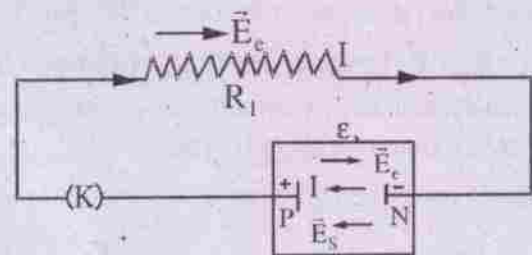

Fig. 6.3

(A closed circuit with current I in the circuit)

The charges on the terminals decrease slightly. \vec{E}_e both within the wire and within the source becomes slightly smaller than \vec{E}_s , which is a constant. Hence +ve charges within the source are driven towards the +ve terminal P and there is the current I from N to P. The current outside the source is due to the field \vec{E}_e which smooths out the flow and makes the current steady practically within no time. It communicates the influence of the source to distant parts of the circuit.

If the source of emf has no internal resistance r , charge entering the external circuit through terminal P would be immediately replaced by charge flow through the source.

Then the internal electrostatic field \vec{E}_e inside the source does not change under complete circuit condition and the terminal potential difference V_{PN} equals ϵ , as no work is done

for the motion of the charges inside the source. If R is the resistance of the external circuit,

$$V_{PN} = IR \quad \text{by Ohm's law}$$

Hence $V_{PN} = \varepsilon = IR$

$$\Rightarrow I = \varepsilon / R \quad \dots(6.1.2)$$

This relation determines the current in the circuit, once ε and R are specified.

When the source has some internal resistance r , which is usually a small

$$\vec{E}_e + \vec{E}_s \neq 0$$

under closed circuit conditions. The net field $\vec{E} (= \vec{E}_s + \vec{E}_e)$ pushes the charges through the internal resistance r within the source and hence there is a potential drop Ir . Then

$$\varepsilon - V_{PN} = Ir$$

$$\Rightarrow \varepsilon - IR = Ir$$

$$\Rightarrow I = \frac{\varepsilon}{R+r} \quad \dots(6.1.3)$$

Here $R+r$ is called the total circuit resistance.

If the terminals of the source are connected by a conductor of nearly zero resistance, the source is said to be short circuited.

The short circuit current $I_s (= \frac{\varepsilon}{r})$ is usually large and may damage the circuit. It should be avoided. The terminal voltage (T.P.D.) under this condition is zero.

The emf ε and internal resistance r completely describe a source. These properties are found from measurements of the open circuit terminal voltage i.e. $\varepsilon = V_{PN}$ and short circuit current i.e. $I_s = \frac{\varepsilon}{r}$.

Sometimes a source is connected to an external circuit containing other sources. This is the case when a storage battery (example - motor battery) is charged by a generator. In that

case the emf of the battery to be charged, is opposite in sign to the current in the circuit. This is shown in fig. 6.4.

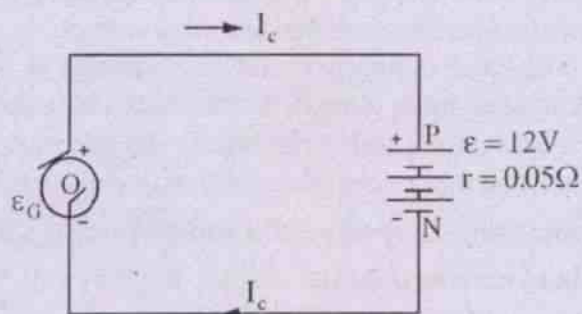

Fig. 6.4

(Charging a battery of emf ε by the charger of emf ε_G)

The generator has emf ε_G and negligible internal resistance whereas the storage battery has emf ε and internal resistance r . In such a case $\varepsilon_G > \varepsilon$ and the electrostatic field \vec{E}_e within the battery is greater than the nonelectrostatic field \vec{E}_s . The charging current I_c within the battery is from P to N as shown in the diagram and it is given by

$$I_c = \frac{\varepsilon_G - \varepsilon}{r} \quad \dots(6.1.4)$$

$$\Rightarrow \varepsilon_G = \varepsilon + I_c r \quad \dots(6.1.5)$$

An ideal source of emf is one which has negligible internal resistance r . However, every real source of emf has some internal resistance which depends on the materials used in the source. For a chemical cell, for example, r depends on the electrolyte, surface area of the electrodes in contact with the electrolyte and its temperature. We shall briefly discuss about some sources of emf in the next section.

One should carefully note the following distinctions between the emf of a source and the potential difference it creates in an external circuit.

emf	potential difference
1. It is the work done by the non electrostatic field within the source to make the +ve charge carriers move from the negative electrode to the +ve electrode.	1. It is the work done per unit charge by the electrostatic field within the resistor to make the charge carriers move from one point to another.
2. It provides the pressure that tends to establish current in the whole circuit.	2. It provides the pressure in a given part of the external path to drive current through that part.
3. It is the cause of potential difference between two points in the external path of the circuit.	3. It is due to the emf of the source connected in the circuit but cannot produce the emf.
4. It is of nonelectrostatic origin and produces the non-electrostatic field which is non-conservative.	4. It is related with the electrostatic field produced outside the source and is thus of electrostatic origin.
5. It is constant for a given source and is independent of current in the circuit.	5. It depends on the current produced in the circuit.

Unit of emf and potential difference

From the discussions made so far, it is evident that ϵ and V have the same units and dimensions. The unit of ϵ or V in S.I. system is joule/coulomb or volt. The dimension is $M^1L^2T^{-3}A^{-1}$.

Example 6.1.1 : A cell of emf 1.5 V has terminal potential difference of 1.2 V when a resistor of 20 ohm is joined to it. Calculate the current in the circuit and the internal resistance of the cell.

Solution :

$$\text{Given } \epsilon = 1.5 \text{ V, } V = 1.2 \text{ V}$$

$$R = 20 \Omega$$

$$\therefore I = \frac{V}{R} = \frac{1.2 \text{ V}}{20 \text{ Ohm}} = 0.06 \text{ A}$$

$$\therefore r = \frac{\epsilon - V}{I} = \frac{1.5 \text{ V} - 1.2 \text{ V}}{0.06 \text{ A}} = \frac{0.3 \text{ V}}{0.06 \text{ A}} = 5 \text{ Ohm}$$

Example 6.1.2 : A dry cell having negligible internal resistance developed a potential difference of 1.56 V. When it was short circuited through an ammeter it furnished a current of 30 A. Calculate the resistance of the ammeter.

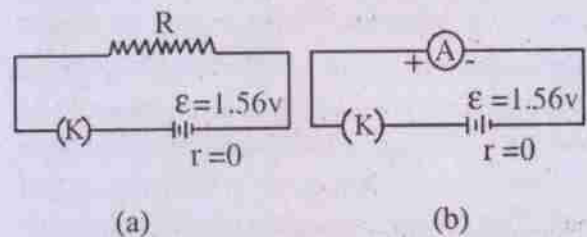

$$\therefore r = 0, \epsilon = V = 1.56 \text{ V} = I R$$

$$\therefore \text{When } R = 0, V = 0; \text{ i.e. the T.P.D.} = 0$$

This condition corresponds to the case when the terminals of the cell are connected by a conductor or device having extremely low resistance such as Ammeter. The cell in this case is short circuited. The current under this condition is the short circuit current (I_s), which is large.

$$\therefore I_s = 30 \text{ A, } R_A = \text{Resistance of ammeter}$$

$$= \frac{1.56 \text{ V}}{30 \text{ A}} = 0.052 \text{ Ohm.}$$

6.2 The sources of e.m.f.

A source of emf. is one which converts some form of nonelectrical energy into electrical energy in a reversible process. Each such source

of emf is called a cell. Dry cell, Motor battery and Generator are some familiar examples of such sources. The other non familiar cells are Thermocouple, Photocell, Fuel cell, Solar cell etc. to name a few. Let us make a brief discussion on the working principles of such cells.

The electrochemical cell

An electrochemical cell is an arrangement in which chemical reactions are made to proceed at a steady rate so as to convert chemical energy into electrical energy constantly. The familiar torch light cell or a dry cell is its common example. The amount of electrical energy provided by these cells is limited by the amount of reaction.

The first electrochemical cell was designed on the basis of the discovery of Luigi Galvani and Alessandro Volta. They showed that if a zinc plate and a copper plate are dipped in a solution of dilute sulphuric acid (H_2SO_4) contained in a glass vessel, electrons could be liberated from the solution onto the zinc plate and absorbed into the solution from the copper plate. This resulted in causing electrical potential difference between them. This was the simple **Voltaic cell** as shown in Fig. 6.5. Here the zinc plate and the copper plate are called the electrodes whereas the solution of H_2SO_4 is called the electrolyte.

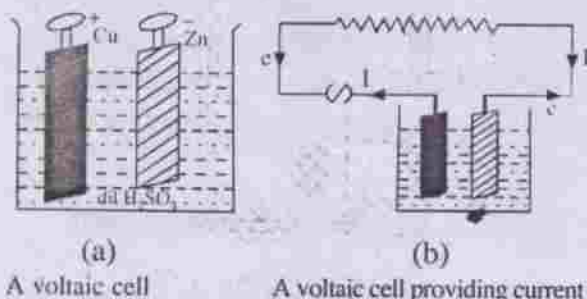
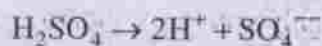

Fig. 6.5

In a voltaic cell dil. H_2SO_4 dissociates as



The hydrogen ions ($2H^+$) move towards the copper plate and take up two free electrons from

it to become a H_2 molecule. This makes the copper plate +vely charged. As the reaction proceeds it develops more +ve potential which can increase upto 0.46 V. At this +ve potential no further H^+ ion can flow towards the copper plate due to electrostatic repulsion, thus creating a state of equilibrium. The sulphate ion (SO_4^{2-}) on the other hand moves towards the zinc plate and delivers the two units of electronic charge to it to make it negatively charged. It reacts with one zinc atom to form zinc sulphate i.e.

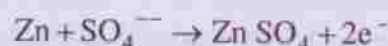

The zinc plate thus develops negative potential till it becomes -0.6 V. Here no further sulphate ion can reach the zinc plate due to electrostatic repulsion and an equilibrium is reached. Thus the total potential difference developed between the plates at equilibrium is $0.46 V - (-0.62V) = 1.08 V$. This becomes the emf of the cell.

When the two terminals of the cell are joined externally by a conducting path electrons from the zinc plate start moving towards the copper plate externally and the equilibrium is lost. The chemical reaction proceeds again and a continuous current is maintained in the path as shown in fig. 6.5b. However, the process is limited as the strength of dil. H_2SO_4 and the zinc plate decreases with gradual use of the cell, which is ultimately discharged. Such a cell cannot be recharged and is called the **Primary Cell**.

Original **Voltaic Cell** had two main defects like (i) local action and (ii) polarization. The first one was due to the impurities in the zinc plate and the second one was due to deposition of hydrogen gas bubbles on the copper plate. These defects minimise the action of the cell and decrease the effective energy provided by it. Later reserches have improved its action by minimising the defects. Local action is reduced by amalgamating the zinc plate with mercury whereas polarization is minimised by using a

suitable oxidizing agent with the cell material to convert the liberated hydrogen into water.

The original voltaic cell has undergone a lot of modifications and many improved forms of primary cells have been designed thereafter. The underlying principle remaining the same, they differ mostly in the choice of their electrodes, the electrolytes and the mechanism of depolarization. Two such cells used in the laboratories are (i) the Daniell cell and (ii) the Leclanche cell.

(i) The Daniell Cell

This cell has a zinc electrode in a solution of H_2SO_4 and a copper electrode in a solution of $CuSO_4$. The two liquids are separated by a porous cup as shown in fig. 6.6. The zinc plate is amalgamated to eliminate the effect of impurities. When the cell is in action SO_4^{2-} ion combines with zinc at the electrode to form

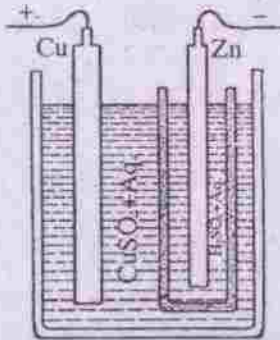

Fig. 6.6

zinc sulphate while $2H^+$ ions move out through the walls of the porous cup. On reaching copper sulphate solution these ions form H_2SO_4 displacing copper. It is deposited at the Cu electrode. The $CuSO_4$ solution thus acts as the depolarizer, as it prevents hydrogen, the most common source of polarization. The internal resistance of the cell is high, however. It is best used when a continuous current for a longer period is desired. Its emf is 1.09 V.

(ii) The Leclanche Cell

In its basic form this cell has zinc and

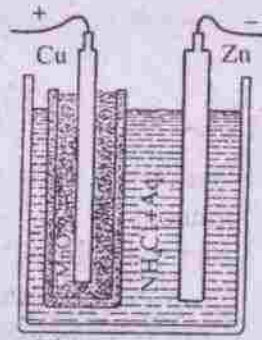

Fig. 6.7

carbon electrodes in a solution of ammonium chloride (NH_4Cl). The carbon electrode is kept in a porous cup packed with manganese peroxide (MnO_2), which acts as the depolarizer, as shown in Fig. 6.7. Here NH_4Cl dissociates to NH_4^+ ion and Cl^- ion. NH_4^+ ions move to carbon where they form ammonia (NH_3) and hydrogen (H_2). The latter reacts with MnO_2 forming Manganese dioxide (Mn_2O_3) and water. As the depolarizing action is somewhat slow, the cell becomes polarized if used continuously. On remaining idle, it recovers. It is therefore used for intermittent service. Its emf is 1.5 V.

(iii) The Dry Cell

The torch light cell or common dry cell is a special form of Leclanche cell. The only difference is that here the depolarizer and the electrolyte are mixed together to form a paste. The cell is contained in a zinc can which serves as the -ve electrode. Its internal resistance is nearly 0.1 ohm. Hence large currents may be drawn momentarily before polarization develops. The cell is portable in size and is readily available in market in different sizes. It is shown in fig. 6.8. Its emf is 1.5 V.

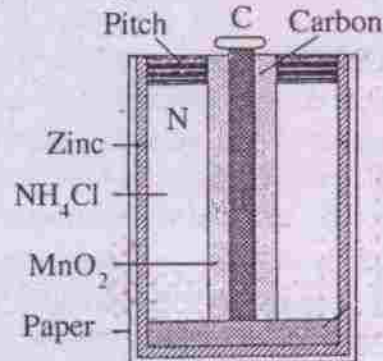
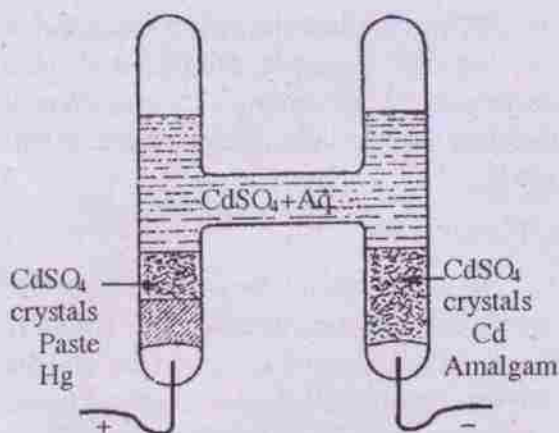

Fig. 6.8 (Dry Cell)

(iv) The Weston Standard cell

The very name indicates that this primary cell provides a highly accurate standard emf. It is contained in a closed glass tube made in H-form. Platinum wires sealed into the glass make

contact with the electrodes which are mercury and cadmium amalgam respectively. Above all mercury is a paste composed of mixed cadmium sulphate and mercurous sulphate which is the depolarizer. Cadmium sulphate is used as the electrolyte. It provides an emf of 1.0816 V at 20°C. This emf has a -ve temperature coefficient with 4 parts in 100000, which indicates that its emf hardly varies. It is shown in fig. 6.9.



(The Weston standard cell)

Fig. 6.9

(v) Secondary Cells (Lead Accumulator)

Electrochemical cells which can be recharged after being used, are known as the **Secondary Cells**. Lead accumulator or Lead-acid cells used as automobile battery is the common example of such cells. It is shown in Fig. 6.10. The cell was devised by Plante in 1859. When fully charged its electrodes are plates of Lead Oxide (PbO_2) as anode and of lead (Pb) in spongy form as cathode. The electrolyte is a solution of sulphuric acid (H_2SO_4) with a specific gravity of 1.20 to 1.28. For larger capacity each electrode consists of a number of plates connected together as shown in fig. 6.10 b, Insulating separators prevent plates of opposite polarity from coming into contact.

On connecting the electrodes externally the cell begins to discharge. The SO_4^{2-} ions of

H_2SO_4 move to the -ve plate i.e. the lead plate to form PbSO_4



At the +ve plate 2H^+ ions reduce PbO_2 to PbO and forms water i.e.

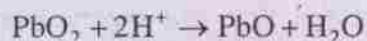

Then PbO combines with H_2SO_4 to form PbSO_4 and further water i.e.

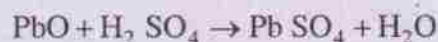

Thus PbSO_4 is produced at both the plates of the cell and this is called the "Double sulphate theory" of the cell. The reactions in charging is exactly in reverse order, when the cell is connected to the d.c. source of charging emf, i.e.

$$\text{H}_2\text{O} \rightarrow 2\text{H}^+ + \text{O}^{2-}$$

At the anode $\text{PbSO}_4 + \text{O}^{2-} + \text{H}_2\text{O} \rightarrow \text{PbO}_2 + \text{H}_2\text{SO}_4$

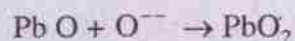

At the cathode $\text{PbSO}_4 + 2\text{H}^+ \rightarrow \text{Pb} + \text{H}_2\text{SO}_4$



As the cell discharges, specific gravity of the electrolyte falls. The cell is said to be fully discharged when it falls to 1.15. The specific gravity should not be allowed to fall beyond that as it causes serious damage to the cell by increasing its internal resistance.

The emf of a fully charged cell is 2.05 V and it falls to 1.8 V when discharged. It is fairly steady. The internal resistance is small i.e. 0.01 ohm or less. As there is no appreciable polarization, current obtained from the cell is large. These are the advantages of the cell. However, it is not ordinarily portable. Its capacity is expressed in Ampere hours.

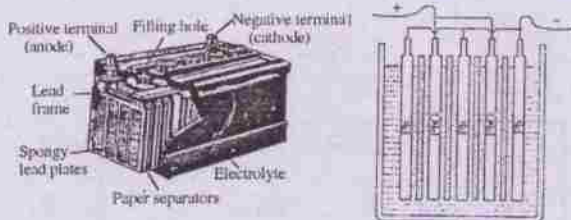

(The Lead Accumulator)

Fig. 6.10 (a)

Fig. 6.10(b)

The internal resistance of an electrochemical cell depends on its electrode area and the cell material. Cells of larger electrode area have less internal resistance. The internal resistance of a brand new cell is less. As the cell is used gradually, it increases.

At high temperature, a cell is discharged more rapidly whereas extremely low temperature slows down the chemical reactions, leading to lower output from the cell. The best operating temperature for a chemical cell is around 27° C.

(b) Magneto-mechanical source

It is the source of emf based on the principle of conversion of mechanical energy into electrical when magnetic flux linked with a coil is made to change with time. The phenomenon called **electromagnetic induction**, was discovered by **Michel Faraday** in 1831. Since then it has been the chief source of generating electrical energy in the modern world. Dynamo or generators work on this principle. All hydroelectric projects, thermal power plants and nuclear power plants use this principle to generate energy. The details of electromagnetic induction will be discussed in chapter 9.

(c) Thermo electric source

Such sources convert **thermal energy into electrical energy directly**. The device is called a thermocouple as shown in fig. 6.11. If the two junctions of two different metals are

maintained at two different temperatures, charge flow occurs in the circuit formed by them and a current is established. The flow continues so long as the temperature difference between the junctions is maintained. The phenomenon is called Seebeck effect and the emf is called Seebeck emf.

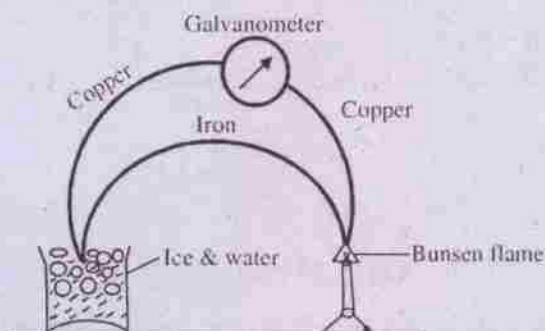

Fig. 6.11 (A thermocouple)

(d) Photo-electric sources

Such sources called the **photocells** are based on the principle of **photoelectric effect**. If light of short wavelength falls on the clean surface of certain metals such as potassium or sodium, electrons are emitted by the surface. When such a surface is made a part of an electric circuit, current is found to exist as shown in fig. 6.12. Thus light energy is converted to electrical energy in a photocell.

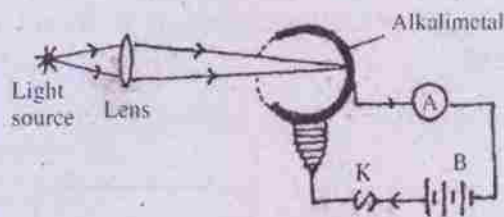

Fig. 6.12 (photo cell)

A **solar cell** is another device which converts light from the sun directly into electrical energy. Here an n-type silicon (a semiconductor device) is sandwiched within a p-type silicon as shown in fig. 6.13. When sunlight falls on the cell, electrons move to the terminal of n-type region and holes to the other terminal on p-type region.

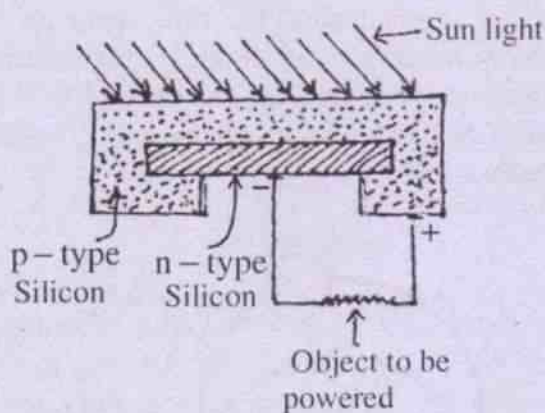

Fig. 6.13 (Solar cell)

On joining the terminals externally one gets current from the cell till it is illuminated by sunlight. Solar cells are in developmental stage and may play an important role in solving the so called energy crisis in future.

(e) Another source of electric current is seen in devices like microphones, oscillators, phonograph pick ups and frequency stabilizers. These devices use some crystals such as quartz, tourmaline, rochellsalt etc. which develop tiny emf between their ends when slight pressures are applied. The phenomenon is called piezoelectric effect. The cell so developed is called a **piezoelectric cell**. The generated emf may be amplified and used. It is shown in fig.6.14.

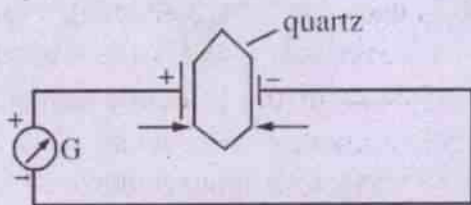

Fig. 6.14

(A piezoelectric source of emf)

6.3 Electrical Circuit accessories

An electrical circuit is a closed path for the motion of charge carriers. A simple d.c. circuit is shown in fig. 6.15. Here

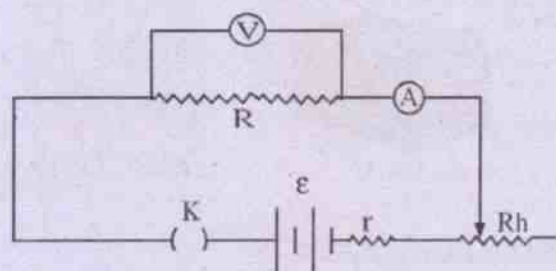

Fig. 6.15

(A simple d.c. circuit)

ϵ is a direct current source of e.m.f.

r is the internal resistance of the source,

K is the switch or key,

R_h is the rheostat (a variable resistance),

R is the external resistor.

V is the volt meter

and A is the ammeter.

All these components of the circuit are known as circuit accessories, about which let us make a brief discussion here.

(a) The source of emf

We have already made some discussion about the different sources of emf. Each such source provides energy to the mobile charge carriers for their motion in a circuit against the circuit resistance. A d.c. source of emf is represented as two parallel straight lines of unequal lengths i.e. ---|---| , the longer one representing the +ve terminal and the shorter one, the -ve terminal. The internal resistance r of each source of emf is represented as ---|---| , adjacent to the source of emf as shown in the circuit diagram. An alternating source or a.c. source of emf is shown as $\text{---(---)}\text{---}$ in the circuit diagram.

(b) The key or switch

It is used to make a circuit operate when it is closed. When the key is open the circuit does not function. It is shown as symbol

$\text{---}(\)\text{---}$ or $\text{---}/\text{---}$ in a circuit diagram. We have seen the switches used in household wiring. The keys or switches used in laboratories are somewhat different from them. Each switch has two conducting parts, each part provided with an insulating portion where it is held or operated by hand for safety. The two conducting parts remain separated when the circuit is open. These are joined or touched together to make the circuit operate. The diagram of two such keys are given in fig. 6.16a and 6.16 b.

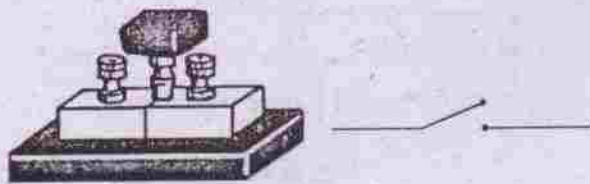

(a) (Plug Key)

(b) (Tap Key)

Fig. 6.16

(c) *The Rheostat*

It is a coil of wire having its resistance proportional to its length. It is used as a variable resistor and connected in the circuit in such a manner that a part of the whole coil is included in the circuit. The resistance is changed by changing a point of sliding contact over the coil so as to include the required length of the coil in the circuit. The diagram of a rheostat is given in fig. 5.12. It is represented by the symbol $\text{---}\text{~}\text{---}$ in the circuit diagram.

(d) *The External resistor*

Resistive wire or coil connected in the circuit is called the external resistor R and its circuit symbol is $\text{---}\text{~}\text{---}$.

(e) *The Voltmeter*

It is a device to measure potential difference between two points in the circuit or the terminal potential difference of a source of emf. It is always connected in parallel with that portion of the circuit between the ends of which potential difference is to be measured as shown

in Fig. 5.8. Its +ve end is connected to the point of higher potential and the -ve end to the point of lower potential. Its resistance is high and the circuit symbol is $\text{---}\text{~}\text{---}$. The details of its construction will be discussed later.

(f) *The Ammeter*

It is a device to measure the current in the circuit and is connected in series with it. The +ve end of the ammeter is connected to the point of higher potential and the -ve end to the lower potential end. Its resistance is negligibly small and its construction details will be made later. In the circuit diagram it is represented by the symbol $\text{---}\text{---}\text{---}$.

(g) *The connecting wires*

These are usually copper wires of low resistance and are represented by the symbol --- in the circuit diagram. Such wires are coated with insulating material for safe handling. The resistance of these wires is not taken into consideration while calculating the total circuit resistance.

Besides these accessories usually used in a simple circuit, there are some others which are used as per requirement. Let us mention in brief some of them.

(h) *The Galvanometer*

It is an instrument used to detect electric current in the circuit. It is connected in series with other components and is represented as $\text{---}\text{---}\text{---}$ in the circuit diagram. In construction a voltmeter or an ammeter is a modified version of a galvanometer. Every galvanometer has some appreciable resistance.

(i) *The Commutator*

It is an arrangement to reverse the direction of current in the whole circuit or in part of the circuit. Fig. 6.17 gives the diagram of a plug type commutator, which is a fourway plug key in practice.

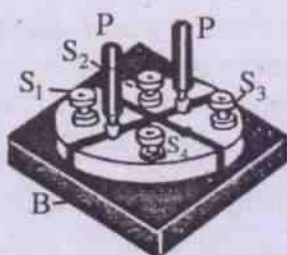

Fig. 6.17 Plug Commutator

6.4 Grouping of resistors and cells

Electric circuits in practice may contain a number of resistors and cells connected in different ways. We may have the following types of combination.

- (i) There may be a single source of emf and a number of resistors connected in a regular pattern.
- (ii) There may be a number of sources of emf connected in a regular pattern, the combination being connected to an effective external resistance R .
- (iii) There may be a number of resistors all combined in complicated ways with or without any regularity among them so that it becomes a network.

In the first and second cases we may solve for circuit currents or other circuit parameters by the application of Ohm's law, which may fail in the third case. There we take resort to the Kirchhoff's rules which will be discussed in due course. Let us analyse the cases one by one.

Case (i) Grouping of resistors

Here a number of resistors are combined in a regular pattern to form a network. The combination has two end points which are connected with the battery or other circuit elements.

The equivalent resistance of the combination is that single resistance which when used in place of the combination draws the same

current for a given potential difference V across the end points. We may have

- (a) series grouping and
- (b) parallel grouping of resistors.

(a) Series grouping

When a number of resistors are connected end to end one by one, these are said to be in series grouping, as shown in fig. 6.18. There are three resistors R_1 , R_2 and R_3 connected between the points A and B of the circuit.

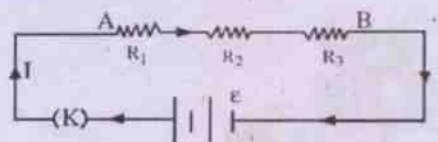

Fig. 6.18

(Series grouping of resistors)

As shown in the diagram the same current I is maintained in all the resistors whereas the potential difference across each of them is different. The effective potential difference V between the points A and B is the sum of the potential differences V_1 , V_2 and V_3 across the resistors R_1 , R_2 , R_3 respectively, i.e.

$$V = V_1 + V_2 + V_3 \quad \dots(6.4.1)$$

According to Ohm's law $V_1 = IR_1$, $V_2 = IR_2$, $V_3 = IR_3$; so that

$$\begin{aligned} V &= I(R_1 + R_2 + R_3) \\ \Rightarrow \frac{V}{I} &= R_1 + R_2 + R_3 \\ \Rightarrow R &= R_1 + R_2 + R_3 \quad \dots 6.4.2 \end{aligned}$$

where R is the effective resistance of the combination. Eqn. 6.4.2 may be generalized if there are n number of resistances $R_1, R_2, \dots, R_1, \dots, R_n$ in series i.e.

$$R = \sum_{i=1}^{i=n} R_i \quad \dots(6.4.3)$$

It is to be noted that in a series combination of resistors

- (i) the equivalent resistance is always greater than any individual resistance,
- (ii) the ratio between any two resistances in series is equal to the ratio of voltage drops across them;

i.e. $\frac{R_1}{R_2} = \frac{V_1}{V_2}$, $\frac{R_2}{R_3} = \frac{V_2}{V_3}$ etc.

- (iii) the more the number of resistors combined in series, the less is the current in the circuit for the same source of emf.

(b) Parallel grouping

If the ends of all the resistors in the group are connected between two common points in the circuit, the combination is called a parallel grouping of resistors.

In fig. 6.19, three resistors having resistances R_1, R_2 and R_3 are shown in parallel combination between two common points A and B. The points A and B are connected to the

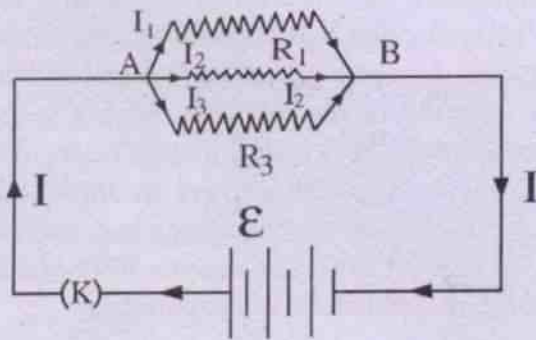

Fig. 6.19
(Parallel grouping of resistors)

terminals of the battery through key K. Here the potential difference between the ends of each resistor i.e. between A and B is the same. Hence the main current I divides itself to I_1, I_2 and I_3 at A to flow through R_1, R_2 and R_3 respectively.

I_1, I_2 and I_3 again mix up at B to flow as current I in the rest part of the circuit. We may write

$$I = I_1 + I_2 + I_3 \quad \dots (6.4.4)$$

where $I_1 = \frac{V}{R_1}$, $I_2 = \frac{V}{R_2}$ and $I_3 = \frac{V}{R_3}$

according to Ohm's law and V is the potential difference between the points A and B. Substituting for I_1, I_2 and I_3 in eq. 6.4.4 we have

$$I = \frac{V}{R_1} + \frac{V}{R_2} + \frac{V}{R_3}$$

$$\Rightarrow \frac{I}{V} = \frac{I}{R_1} + \frac{I}{R_2} + \frac{I}{R_3} \quad \dots(6.4.5)$$

If the effective resistance between A and B is taken as R , then $\frac{I}{R} = \frac{I}{V}$ by Ohm's law. Hence from eq. 6.45

$$\frac{1}{R} = \frac{1}{R_1} + \frac{1}{R_2} + \frac{1}{R_3} \quad \dots(6.4.6)$$

Obviously R is the equivalent resistance of the combination of R_1, R_2 and R_3 in fig. 6.19. For n no. of resistors having resistances $R_1, R_2, R_3, \dots, R_n$, connected in parallel, eq. 6.4.6 may be generalised as

$$\frac{1}{R} = \sum_{i=1}^{i=n} \frac{1}{R_i} \quad \dots(6.4.7)$$

It is to be noted that in parallel grouping of resistors

- (i) The equivalent resistance is always less than the lowest resistance of the group.
- (ii) The ratio of currents in any two resistors is equal to the inverse ratio of their respective resistances. i.e.

The equivalent resistance of the combination is $\frac{R_2}{R_1}$ etc.

$$\frac{I_1}{I_2} = \frac{R_2}{R_1} \text{ etc.}$$

- (iii) The total current is the sum of individual path currents i.e. $I = I_1 + I_2 + I_3, \dots$
- (iv) The voltage is the same across all resistors in parallel.

(c) Mixed grouping

When some resistors in a net work are combined in parallel and some others are in series, the equivalent resistance is calculated as follows.

- (i) At first the equivalent resistance of all resistors in parallel is calculated using eq. 6.4.7 and it is denoted as R_p .
- (ii) The total resistance of the mixed grouping is found by adding R_p with all other resistances in series according to eq. 6.4.3.

Ex. 6.4.1 Calculate the equivalent resistance of the combination of resistors in fig. 6.19 if R_1, R_2 and R_3 are respectively $2\Omega, 4\Omega$ and 8Ω .

$$\text{Here } \frac{1}{R_p} = \left(\frac{1}{R_1} + \frac{1}{R_2} + \frac{1}{R_3} \right)$$

$$= \left(\frac{1}{2} + \frac{1}{4} + \frac{1}{8} \right) \text{ ohm}^{-1} = \frac{7}{8} \text{ ohm}^{-1}$$

$$\therefore R_p = \frac{1}{7/8} \text{ ohm} = \frac{8}{7} \text{ ohm} = 1.143 \text{ ohm}$$

Ex. 6.4.2 Calculate the equivalent resistance of the circuit given below and find the current in each resistor.

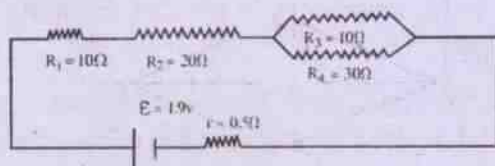

Here R_1 and R_2 are in series. Their effective resistance $R_s = R_1 + R_2 = 10\Omega + 20\Omega = 30\Omega$

Since R_3 and R_4 are in parallel

$$\frac{1}{R_p} = \frac{1}{R_3} + \frac{1}{R_4}$$

so that

$$R_p = \frac{R_3 R_4}{R_3 + R_4} = \frac{10 \times 30}{10 + 30} \Omega = \frac{30}{4} = 7.5\Omega$$

\therefore Total resistance R_t of the circuit is given as

$$R_t = R_s + R_p + r = 30\Omega + 7.5\Omega + 0.5\Omega = 38\Omega$$

$$\therefore I = \frac{E}{R_t} = \frac{1.9V}{38\Omega} = 0.05A$$

6.5 Grouping of cells

Cells are often combined in groups to get larger emf or larger current. There may be (a) series grouping, (b) parallel grouping, (c) mixed grouping of cells.

(a) Series grouping of cells

When a number of cells are joined end to end so that the same quantity of electricity must flow through each, the grouping is known as series grouping. In such a case, the -ve terminal of the first cell is connected to the +ve terminal of the second, the -ve terminal of the second is connected to the +ve terminal of the third and so on. The external resistor is connected between the +ve terminal of first cell and the -ve terminal of the last one. Such a series combination of cells is shown in fig. 6.20(a) and 6.20 (b). In fig. 6.20 (a) there are three cells each of emf ϵ and internal resistance r , whereas in fig. 6.20(b), the cells in series differ in emf and internal resistance r . In either case

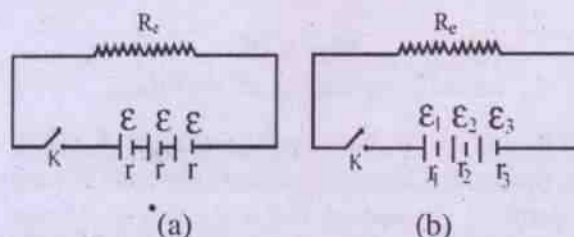

Fig 6. 20 (Series grouping of cells)

1. The emf of the battery is equal to the sum of the emf's of the individual cells, i.e. in fig. 6.20 a, the emf of the battery $\epsilon_b = 3 \epsilon$ and in fig. 6.20 b $\epsilon_b = \epsilon_1 + \epsilon_2 + \epsilon_3$. The same principle applies for n cells in series, i.e. $\epsilon_b = \epsilon_1 + \epsilon_2 + \epsilon_3 + \dots + \epsilon_n$... (6.5.1)
2. The current in each cell is the same and is identical with its main current in the circuit.
3. The total internal resistance r_c is equal to the sum of the internal resistance of each cell, i.e.

$$r_c = r_1 + r_2 + r_3 + \dots \quad \dots(6.5.2)$$

If we take a combination of n identical cells each of emf ϵ and internal resistance r, the effective emf of the combination $\epsilon_b = n \epsilon$ and the effective internal resistance $r_c = nr$. Then total resistance of the circuit = $nr + R_e$ and the current I drawn from the arrangement is given by

$$I = \frac{n\epsilon}{nr + R_e} \quad \dots(6.5.3)$$

In eq. 6.5.3 if $R_e \ll nr$ i.e. total external resistance is negligible in comparison with total internal resistance,

$$I = \frac{n\epsilon}{nr + R_e} \approx \frac{n\epsilon}{nr} = \frac{\epsilon}{r} \quad \dots(6.5.3)$$

Here the current in the circuit due to n cells in series is that due to a single cell and the grouping has no advantage. On the otherhand if $R_e \gg nr$, then the total internal resistance is negligible in comparison with the total external resistance

and
$$I = \frac{n\epsilon}{nr + R_e} \approx \frac{n\epsilon}{R_e} \quad \dots(6.5.4)$$

so that the current in the circuit becomes n times the current due to a single cell.

Almost in all practical cases, r of cells being small, the series grouping of cells has the

advantage of increasing the current in the circuit.

Ex. 6.5.1 If the emf and internal resistance of each cell in fig 6.20 a is 1.5 V and 0.2 Ω respectively and $R_e = 17.4 \Omega$ find the current in the middle cell of the combination.

Here total emf = $3 \times 1.5 \text{ V} = 4.5 \text{ V}$
 total resistance of the circuit = $3 \times 0.2 \Omega + 17.4 \Omega = 18 \Omega$

$$\therefore I = \frac{n\epsilon}{nr + R_e} = \frac{4.5\text{V}}{18 \text{ ohm}} = 0.25 \text{ A}$$

\therefore the current in each cell is the same in series combination and is equal to the main current in circuit, the current in the middle cell = 0.25 A.

(b) Parallel grouping of cells

A number of cells are said to be connected in parallel if the positive terminals of all the cells are connected to one common point and the negative terminals to another common point. These two common points are connected to the external resistor of resistance R_e . In fig. 6.21 is shown the parallel grouping of three cells each of emf ϵ and internal resistance r. A and B are the two common points where the +ve and -ve terminals of all the cells have been connected respectively. R_e is the effective external resistance connected between A and B through the key K.

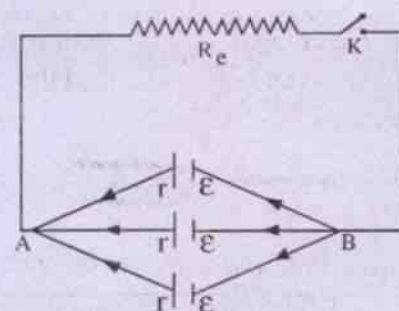

Fig. 6.21

(Parallel grouping of cells)

In such a combination of cells

1. the emf of the combination is equal to the emf of each cell. Thus the effective emf in Fig. 6.21 is $\epsilon_e = \epsilon$,
2. since the internal resistance of each identical cell is the same, the effective internal resistance r_e is given by

$$\frac{1}{r_e} = \frac{1}{r} + \frac{1}{r} + \frac{1}{r} + \dots$$

(Thus for n cells each of internal resistance r and emf ϵ $r_e = \frac{r}{n}$)

3. The total current in the circuit is given by

$$I = \frac{\epsilon}{r_e + R_e} = \frac{\epsilon}{\frac{r}{n} + R_e} = \frac{n\epsilon}{nR_e + r} \quad \dots(6.5.5)$$

It is equally divided among all the cells.

It is seen that if $R_e \gg r_e$, then r_e is negligible in comparison with nR_e in eqn. 6.5.5 and

$$I = \frac{n\epsilon}{nR_e} = \frac{\epsilon}{R_e} \quad \dots(6.5.6)$$

i.e. the current in the circuit is equal to that due to a single cell.

If the internal resistance r of each cell is so large that R_e is negligible in comparison with r . Then, from eq. 6.5.5

$$I = \frac{\epsilon}{\frac{r}{n}} = \frac{n\epsilon}{r} \quad \dots(6.5.7)$$

This shows that the current in the circuit becomes n times the current due to each individual cell.

Ex. 6.5.2 Calculate the current in the circuit and that in each individual cell in fig. 6.21 if ϵ and r of each cell are 2V and 0.2 Ω respectively

and $R_e = 10 \Omega$.

Here three identical cells are in parallel. Thus $n = 3$, $\epsilon = 2V$, $r = 0.2 \Omega$ and $R_e = 10 \Omega$

\therefore From eq. 6.5.5

$$I = \frac{3 \times 2V}{3 \times 10\Omega + 0.2\Omega} = \frac{6V}{30.2\Omega} = 0.199A$$

\therefore I is equally divided among all the 3 cells then

$$\text{current in each cell} = \frac{1.999A}{3} = 0.0667A.$$

(c) Mixed grouping of cells

Sometimes cells are grouped in series and in parallel to get a desired current. It is particularly necessary when the internal resistance of the cells cannot be neglected in comparison with the external resistance R_e . Let us take a combination in which all the cells have the same emf ϵ and same internal resistance r . Let there be m rows of cells connected in parallel with n cells in series in each row as shown in Fig. 6.22 where $m = 3$ and $n = 4$.

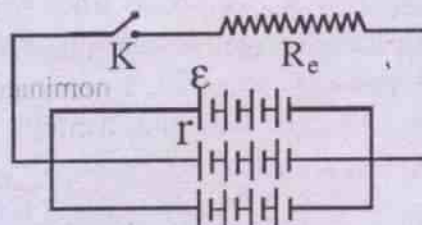

Fig. 6.22

(Mixed grouping of cells)

Obviously the effective emf of each row = $n\epsilon = \epsilon_s$ (say) since there are n cells in series. Also the effective internal resistance of each row = $nr = r_s$ (say). As there are m rows of cells in parallel, the effective emf ϵ_e of the combination = the effective emf of each row. Thus

$$\epsilon_e = \epsilon_s = n\epsilon \quad \dots(6.5.8)$$

Similarly the effective internal resistance r_e of the combination is given by

$$\frac{1}{r_e} = \frac{1}{r_s} + \frac{1}{r_s} + \dots m \text{ times}$$

$$\Rightarrow \frac{1}{r_e} = \frac{m}{r_s} = \frac{m}{nr}$$

$$\Rightarrow r_e = \frac{nr}{m} \quad \dots(6.5.9)$$

The total resistance of the circuit is given by

$$R_t = R_e + r_e = R_e + \frac{nr}{m} \quad \dots(6.5.9)$$

where R_e stands for the effective external resistance. The current in the circuit is given by

$$I = \frac{\varepsilon_e}{R_t} = \frac{n\varepsilon}{R_e + \frac{nr}{m}}$$

$$\Rightarrow I = \frac{mn\varepsilon}{mR_e + nr} \quad \dots(6.5.10)$$

Condition for maximum current

Since the numerator in the R.H.S. of eq. 6.5.10 is a constant, the current in the circuit becomes maximum when the denominator is minimum. We may write the denominator $mR_e + nr$ as follows.

$$mR_e + nr = (\sqrt{mR_e})^2 + (\sqrt{nr})^2$$

$$= (\sqrt{mR_e} - \sqrt{nr})^2 + 2\sqrt{mnR_e r}$$

$\therefore 2\sqrt{mnR_e r}$ is a fixed quantity in a given combination, $(mR_e + nr)$ is minimum when $(\sqrt{mR_e} - \sqrt{nr})^2 = 0$. This leads to the condition that

$$mR_e = nr$$

$$\Rightarrow R_e = \frac{nr}{m} = r_e \quad \dots(6.5.11)$$

Thus the maximum current is obtained for the circuit when the effective internal resistance of all the cells becomes equal to the effective external resistance. Such maximum current I_{\max} is given by

$$I_{\max} = \frac{mn\varepsilon}{2\sqrt{mnR_e r}} = \frac{mn\varepsilon}{2\sqrt{mR_e} \cdot \sqrt{nr}}$$

$$\Rightarrow I_{\max} = \frac{mn\varepsilon}{2mR_e} \text{ or } \frac{m\varepsilon}{2nr} \text{ (Using eq. 6.5.11)}$$

$$\Rightarrow I_{\max} = \frac{n\varepsilon}{2R_e} \text{ or } \frac{m\varepsilon}{2r} \quad \dots(6.5.12)$$

6.6 Kirchhoff's laws and their application to any network :

The rules and formulae discussed in cases (i) and (ii) to calculate effective resistance, effective emf and currents in series, parallel and mixed groupings of resistors and cells are based on the application of Ohm's law. Very often it fails to solve for unknown circuit parameters of any complicated network of conductors and cells. In such cases the two laws or rules formulated by **Gustav Robert Kirchhoff** (1824-87) become very effective in solving for the unknown quantities.

Kirchhoff's first law

At any junction of an electrical circuit, the sum of the currents directed towards the junction is equal to the sum of those leaving the junction. It is the same as stating that

"At any junction of an electrical network, the algebraic sum of currents is zero."

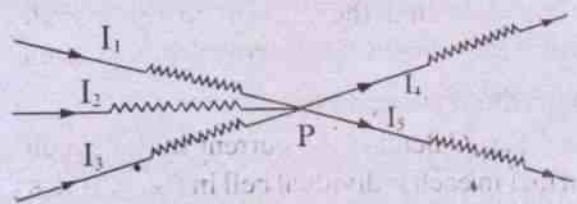

Fig. 6.23

Explanation :

The junction in an electrical network means a point where two or more different conductors meet. It is also called a branch point or a node.

In fig. 6.23, P is identified as a junction where conductors 1, 2 and 3 carrying currents I_1 , I_2 and I_3 respectively, meet and currents I_4 and I_5 flow out through conductors 4 and 5. Then according to Kirchhoff's 1st law

$$I_1 + I_2 + I_3 = I_4 + I_5 \quad \dots (6.6.1)$$

$$\Rightarrow I_1 + I_2 + I_3 - I_4 - I_5 = 0 \quad \dots(6.6.2)$$

Eq. 6.6.2 is the mathematical version of the first law. The convention followed to get this equation is that currents directed towards the junction are taken as +ve and those leaving the junction are taken -ve. Accordingly eq. 6.6.2 can be written as

$$I_1 + I_2 + I_3 + (-I_4) + (-I_5) = 0 \quad \dots(6.6.3)$$

which establishes the second statement of the law. Let us multiply time Δt on either side of eq. 6.6.1. Then

$$I_1 \Delta t + I_2 \Delta t + I_3 \Delta t = I_4 \Delta t + I_5 \Delta t$$

$$\Rightarrow \Delta Q_1 + \Delta Q_2 + \Delta Q_3 = \Delta Q_4 + \Delta Q_5 \quad \dots(6.6.4)$$

The L.H.S. of eq. 6.6.4 represents the charges flowing through conductors 1, 2 and 3 towards P and the R.H.S. represents the charges flowing out of P in time Δt . It means that there is no accumulation of charge at the junction at any time, which is otherwise known as the *Principle of conservation of charge* i.e.

"Charge is neither created nor destroyed but is moved from place to place."

Kirchhoff's second law

"The algebraic sum of emf's round a loop in an electrical network is equal to the algebraic sum of voltage drops around the loop."

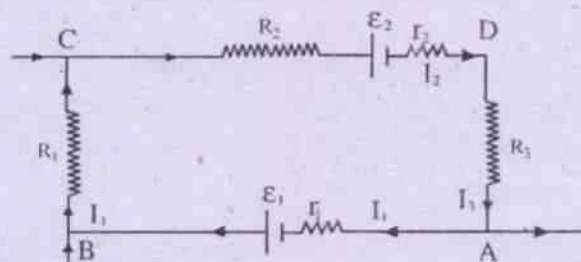

Fig. 6.24

Explanation :

Here loop means a closed conducting path in the network. ABCDA shown in fig. 6.24 is such a loop of certain electrical network.

It contains two sources of emf's ϵ_1 and ϵ_2 having internal resistances r_1 and r_2 respectively. R_1 , R_2 and R_3 are three resistances present in the loop. The currents in different parts of the loop are indicated in the figure.

In such a loop we may trace an element of charge from A to B to C to D and back to A. In this path the charge encounters rise and fall of potential. Let us follow the convention that

(i) an element of charge passing through a source of emf in the direction of emf i.e. from -ve terminal to +ve terminal, is raised in potential by the amount of emf. It implies that here the charge gains energy.

Consequently there is fall of potential or loss of energy if the charge moves through the source of emf in the opposite sense i.e. from the +ve terminal to the -ve terminal.

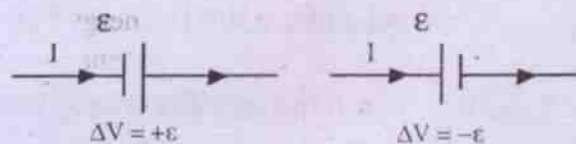

(gain of energy)

(loss of energy)

(ii) an element of charge passing through a resistor in the direction of current loses energy in the form of heat and consequently faces a fall of potential or potential drop by IR .

It implies that in passing through a resistor opposite to the direction of current an element of charge has -ve loss of energy which means that it has gain of energy. Thus it faces a rise in potential or has -ve potential drop.

The convention followed for any resistor also applies to the internal resistance of a battery or a cell.

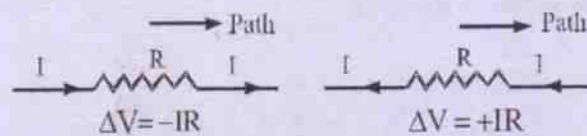

Let us apply these two conventions and consider the motion of an element of charge through the loop ABCDA of fig. 6.24.

From A to B energy gain per unit charge or rise in potential = ϵ_1

energy loss per unit charge or fall of potential = $I_1 r_1$

(By conventions (i) and (ii) respectively)

From C to D energy loss per unit charge or fall of potential = $I_4 R_1$

[Convention (ii)]

From C to D energy loss per unit charge or fall of potential = $I_2 R_2 + I_2 r_2$

[Convention (i)]

From D to A energy loss per unit charge or fall of potential = $I_3 R_3$

[Convention (ii)]

Hence for the entire loop ABCDA energy gain per unit charge or rise in potential = $\epsilon_1 - I_1 r_1 - I_4 R_1 - I_2 R_2 - I_2 r_2 - \epsilon_2 - I_3 R_3$. As all these energy changes take place under an electrostatic field which is a conservative one, their sum must vanish i.e.

$$\begin{aligned} \epsilon_1 - I_1 r_1 - I_4 R_1 - I_2 R_2 - I_2 r_2 - \epsilon_2 - I_3 R_3 &= 0 \\ \Rightarrow \epsilon_1 - \epsilon_2 &= I_1 r_1 + I_4 R_1 + I_2 (R_2 + r_2) + I_3 R_3 \end{aligned} \quad \dots(6.6.5)$$

Eq. 6.6.5 is thus the mathematical statement of Kirchhoff's second law as applied to loop ABCDA. It is based on the principle of conservation of energy.

Application of the laws

Kirchhoff's laws are used to solve for unknown quantities like current, potential difference, emf, resistance etc. in a network of conductors and cells. The procedure for such solution is as follows.

1. The junctions and loops are to be properly identified.
2. Unknown currents, if any, in the network are to be indicated by I_1, I_2, I_3, \dots etc. in the different branches and arbitrary directions are assigned to them.
3. Independent equations equal to the number of unknown quantities in the network are developed using the first law and the second law of Kirchhoff.
4. These equations are solved to find the unknowns.
5. In case of unknown currents, if the solution comes out to be negative, the true direction of current in the branch is to be taken in the opposite direction of the assumed one.

N.B. : Special care should be taken to see that the simultaneous equations which are developed are all independent.

Let us illustrate it with an example and solve

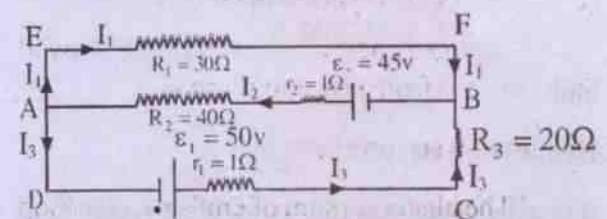

Fig. 6.25

for the currents in the three resistors R_1 , R_2 and R_3 in the circuit diagram given in fig. 6.25 with the data as indicated in the diagram. Let the currents be I_1 , I_2 and I_3 in the three resistors, their directions being indicated by the arrows. Three independent equations are needed to be solved to find R_1 , R_2 and R_3 . Applying Kirchhoff's 1st law to junction A, we have

$$I_2 = I_1 + I_3 \quad \dots(i)$$

(Note that the current equation for junction B is the same as that for A and need not be taken. It is always advisable to write such equations for all but one junction.)

Applying Kirchhoff's second law to the loop ABCDA

$$40 I_2 + I_2 - 45 + 20 I_3 + I_3 - 50 = 0$$

$$\Rightarrow 41 I_2 + 21 I_3 = 95 \quad \dots(ii)$$

The same law applied to loop AEFBA gives

$$-30 I_1 + 45 - I_2 - 40 I_2 = 0$$

$$\Rightarrow 30 I_1 + 41 I_2 = 45 \quad \dots(iii)$$

The loop equation for the loop AEFBCDA need not be written in this case. Now using equation (i) in equations (ii) and (iii) respectively we have

$$41 I_1 + 41 I_3 + 21 I_3 = 95 \quad \dots(iv)$$

$$\text{and } 30 I_1 + 41 I_1 + 41 I_3 = 45 \quad \dots(v)$$

$$\text{i.e. } 41 I_1 + 62 I_3 = 95 \quad \text{from (iv) } \dots(vi)$$

$$\text{and } 71 I_1 + 41 I_3 = 45 \quad \text{from (v) } \dots(vii)$$

Solving these two simultaneous equations for I_1 and I_3 we have

$$I_1 = -0.406 \text{ A}$$

$$\text{and } I_3 = 1.801 \text{ A}$$

Hence from eq. (i) $I_2 = 1.395 \text{ A}$

It is to be noted that the -ve sign for I_1 indicates that the actual direction of current in the branch EF is from F to E, not from E to F. The directions of I_2 and I_3 as indicated are correct.

Application of Kirchhoff's rules to a balanced wheat stone's bridge

A Wheatstone's bridge is an experimental arrangement for measurement of unknown resistance. It contains four resistances P, Q, R, S out of which three are known and the fourth is unknown. The circuit diagram of the bridge is given in fig. 6.26.

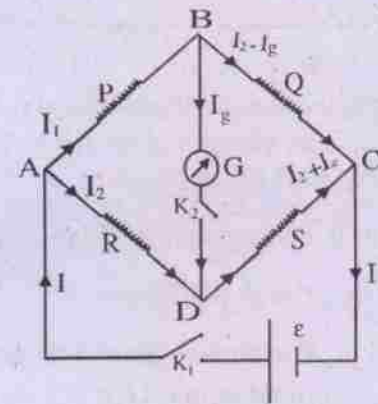

Fig. 6.26 (Wheatstone's bridge)

In the diagram P and Q are connected in series at the junction B and R and S are connected in series at the junction D. The two series combinations are connected in parallel at the junctions A and C. Besides these resistors the bridge contains a battery of emf ϵ connected between A and C through key K_1 . It also contains a galvanometer G connected between B and D through key K_2 .

The battery maintains a current in the circuit when K_1 is closed whereas the galvanometer detects the current, if any, in the path BD when K_2 is closed.

In one particular arrangement, the resistances P and Q are so chosen that their ratio P/Q becomes a fixed one. Then the resistance R is adjusted in a given sequence to get no current in the galvanometer by closing the keys K_1 and K_2 . No current in the galvanometer is indicated by null deflection of its pointer from its normal position. A practical example of this arrangement is seen in a post office box.

In another arrangement R is given a fixed value and the resistances P and Q are adjusted till no deflection is obtained in the galvanometer. Measurement of unknown resistance using a meterbridge is an example of this arrangement.

In either of the arrangements the bridge is said to be balanced for no current in the galvanometer. Under this condition the resistances P, Q, R and S satisfy the relation

$$\frac{P}{Q} = \frac{R}{S} \quad \dots(6.6.6)$$

which enables one to find the unknown resistance S, knowing P, Q, R from eq. 6.6.6.

The condition represented by eq. 6.6.6 is obtained by applying Kirchoff's law as follows.

In Fig. 6.26 let the main current be I which divides itself into I_1 and I_2 at junction A so that we have

$$I = I_1 + I_2 \quad \dots(6.6.7)$$

(from Kirchoff's first law)

The current I_1 is further divided into I_g and $I_1 - I_g$ at B which flow respectively through the branches BC and BD of the bridge. I_g unites with I_2 at D so that the current through DC becomes $I_2 + I_g$. This current meets with $I_1 - I_g$ of the branch BC at C so that it becomes the main current I to flow through the rest of the circuit. I_g represents the current through the galvanometer.

Applying Kirchoff's second law to the loop ABDA and BCDB respectively we have two equations

$$-I_1 P - I_g G + I_2 R = 0 \quad \dots(6.6.8)$$

$$\text{and } -(I_1 - I_g) Q + (I_2 + I_g) S + I_g G = 0 \quad \dots(6.6.9)$$

Here G is taken as the resistance of the galvanometer.

The three simultaneous equations can be

solved to obtain an expression for the current I_g in terms of the other parameters. However, the process is lengthy and tedious as it is hardly of any use except that we put $I_g = 0$ to obtain the balancing condition of the bridge. Hence let us avoid it. On the other hand let us put $I_g = 0$ in equations 6.6.8 and 6.6.9 as it is the balancing condition. We now obtain respectively from eq. 6.6.8 and eq. 6.6.9

$$-I_1 P + I_2 R = 0 \quad \dots(6.6.10)$$

$$\text{and } -I_1 Q + I_2 S = 0 \quad \dots(6.6.11)$$

From these two equations it is easily obtained that

$$\frac{P}{Q} = \frac{R}{S}$$

which is the relation given by eq. 6.6.6 among the four resistances of the bridge under the balancing condition. This relation helps us to find S which is usually taken as the unknown resistance when P, Q and R are known.

Two familiar devices used for making practical Wheatstone's bridge are (i) Meter Bridge and (ii) Post-office Box and these are shown in figures 6.27 and 6.28 respectively. The adjustments have been hinted earlier to obtain the balancing condition. The students are advised to go through any intermediate practical book to find the detailed procedure.

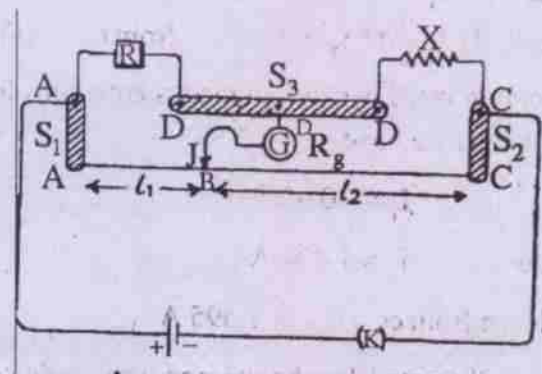

Fig. 6.27

A metre bridge

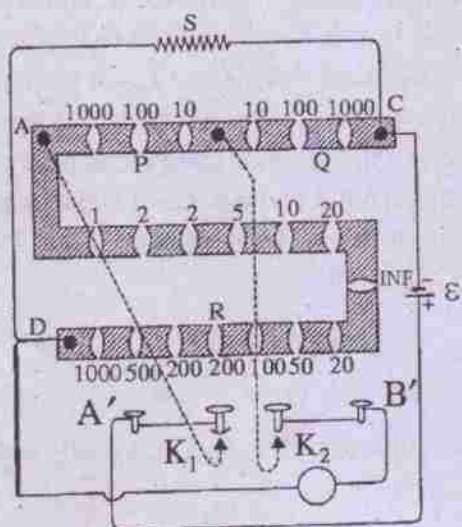

Fig. 6.28
(Post office box)

6.7 Potentiometer:

Potentiometer or called stretched-wire potentiometer is a device which does not draw any current from the given circuit and still measures potential difference. Thus it is equivalent to an ideal voltmeter.

Potentiometer consists of a long wire AB, nearly 5 to 10 meters long, fixed on a wooden board (fig.6.29). Usually, pieces of wire each of 1 meter long are joined through thick copper strips end to end, so that they act as a single wire of length 5-10 meters.

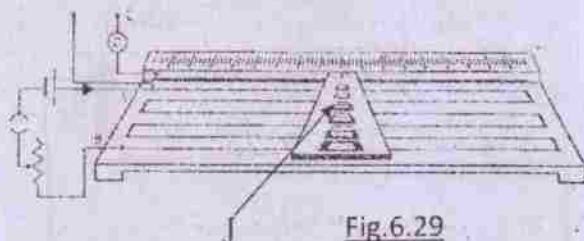

Fig.6.29

Principle: The ends A and B are connected to a driving circuit, consisting of a rheostat R_h , a strong battery E , and a plug key K . The driving circuit sends a current i through the wire AB. This creates a potential gradient, decreasing from A to B. One end of the galvanometer is

connected to a metal rod fixed on the wooden platform (/board). A set of Jockeys fixed on a small board slides on the metal rod. The jockeys are so arranged that we can make a touch with the desired wire by pressing the jockey just lying above that wire piece. In this way the galvanometer gets connected to a point J of wire AB. The length of the wire between A and J is measured with the help of the scale S fixed on the wooden platform. The other end C of the galvanometer and the high potential end A of the wire, form the two end points (terminals) of the potentiometer. These points are connected to the points between which potential difference is to be measured.

Applications:

A. Measurement of potential difference (P.D.):

Suppose we need to measure P.D. between two points 'P' and 'Q'. Let 'P' be at a higher potential and 'Q' at a lower potential. Now connect the point 'P' to the end A and point 'Q' to the end of C of the galvanometer. The circuit is shown in fig.6.30. AB schematically shows the potentiometer wire. Then the jockey is touched at J such that there is no deflection in the galvanometer. This implies J and Q are at same potential. Suppose, the driving circuit sets up a

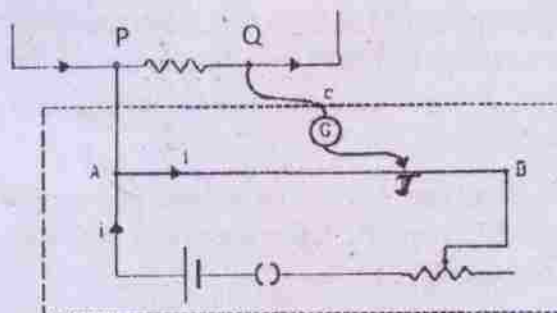

Fig.6.30

potential difference V_0 between ends A and B of the potentiometer wire. As the wire is uniform, the resistance of a piece of wire is proportional to its length. Hence P.D. across a piece of wire is also proportional to its length.

If $AB = L$ and $AP = l$, then P.D. between points and J is $V = V_0 \frac{l}{L}$ -----(6.7.1)

This is equal to P.D. between P and Q, which was our aim to measure. Now in order to know V we need to know V_0 the total potential drop across AB. If the EMF of the standard cell is ϵ and the potentiometer is balanced when $AJ = l_0$, then from eqn. 6.7.1

$$\epsilon = V_0 \frac{l_0}{L} \Rightarrow V_0 = \frac{L}{l_0} \epsilon$$
 -----(6.7.2)

This gives $V = \frac{l}{l_0} \epsilon$

This process of finding V_0 is called calibration of the potentiometer. it is to be noted that when the potentiometer is balanced during its calibration there is no current through the standard cell.

B. Comparision of Emf to two cells:

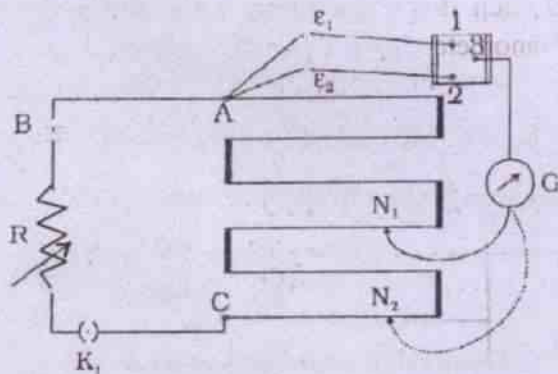

Fig.6.31

The driving circuit of the potentiometer is set up with a strong battery 'B' and a variable resistor (rheostat) R so that potential difference V_0 across AB shall be definitely larger than the emf of the cells which are to be compared. First of all 1 and 3 are connected so that cell of emf ϵ_1 is included in the circuit. Then the Jockey is

moved on potentiometer wire until we get the balance point N_1 . If AN_1 be of length l_1 , then as per eqn. 6.7.1 we have

$$\epsilon_1 = V_0 \frac{l_1}{L}$$
 -----(6.7.4)

Then 2 and 3 are connected so that cell of emf ϵ_2 is included in the circuit. Again the Jockey is moved on the potentiometer wire until we get the balance point N_2 . If AN_2 be of length l_2 , then as per eqn. 6.7.1 we have

$$\epsilon_2 = V_0 \frac{l_2}{L}$$
 -----(6.7.5)

From eqn. 6.7.4 and 6.7.5 we get

$$\frac{\epsilon_1}{\epsilon_2} = \frac{l_1}{l_2}$$
 -----(6.7.6)

The value of emf of a cell can be also measured by taking one of the two cells a standard cell of known emf.

C. Measurement of internal resistance of a cell.

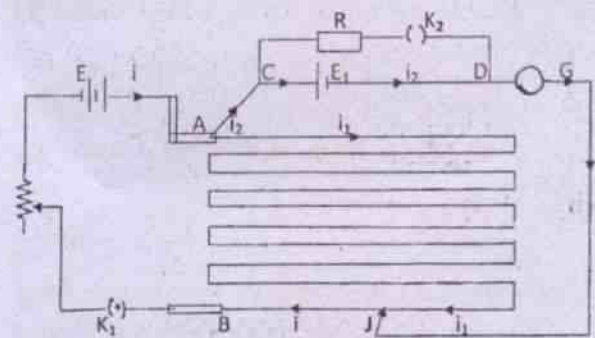

Fig.6.32

The circuit is completed as per fig.6.32. The key K_1 is closed and K_2 is kept open and then applying Kirchoff's laws and analyzing we obtain

$$E_1 - i_2(r + G) - i_1 l_1 = -E_1$$
 -----(6.7.7)

Then the Jockey is moved until a null point J_1 is reached. In this situation no current ($i_2 = 0$) flows

through the galvanometer as well as the cell E_1 and resistance R . So if length of AJ_1 be l_1

$$i_1 \lambda l_1 = E_1 \quad \text{-----(6.7.7)}$$

Where $\lambda = \frac{V_0}{L}$ is the potential gradient, V_0 is potential drop over AB and L is the length of AB . Next both keys K_1 and K_2 are both closed (See fig. 6.3.3) and balance point J_2 is obtained, giving length of AJ_2 equal to l_2 . Applying Kirchhoff's law

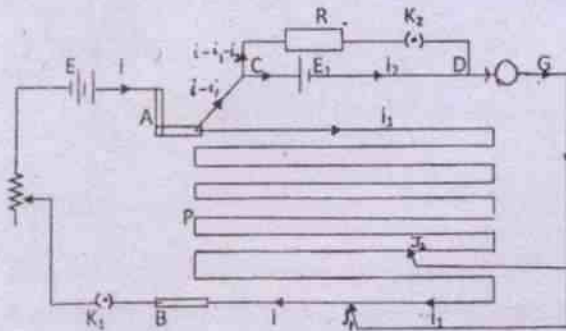

Fig.6.33

and analyzing we obtain

$$i_2 r - (i - i_1 - i_2)R = -E_1 \quad \text{-----(6.7.8)}$$

The current ($i_x = i - i_1$) flows through the galvanometer. On moving the Jockey again another balance point J_2 is reached. From eqn. 6.7.8 we get

$$i_2(r + R) = -E_1 \quad \text{-----(6.7.9)}$$

Again applying Kirchhoff's law to the loop $ACD G J_2 P A$ we get under balanced condition ($i_x = 0$)

$$i_2 r - i_1 \lambda l_2 = -E_1 \quad \text{-----(6.7.10)}$$

Solving eqns. 6.7.9 and 10 we obtain

$$\frac{r}{r + R} + \frac{l_1}{l_2} = 1 \text{ which finally gives}$$

$$r = \frac{l_1 - l_2}{l_2} R \quad \text{---(6.7.11)}$$

Using equation 6.7.11 we can find the internal resistance of the given cell. The potentiometer has the advantage that it draws no current from the voltage source being measured. This ensures no interference with internal resistance of the cell.

Worked out Miscellaneous examples

Example 6.1 : A lead acid accumulator has six cells each of emf $\epsilon = 1.5$ V and internal resistance 0.015Ω . If it provides current to a 8.5Ω resistor calculate the same drawn from the supply and the terminal potential difference of the cell.

Solution :

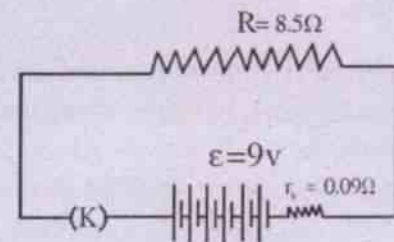

The circuit diagram being given as above, we have

$$\epsilon = 1.5 \text{ V} \times 6 = 9\text{V}$$

$$r_c = 0.015 \Omega \times 6 = 0.09 \Omega$$

$$\therefore R_t = r_c + R = 0.09 \Omega + 8.5 \Omega = 8.59 \Omega$$

\therefore Current drawn from the source =

$$I = \frac{\epsilon}{R_t} = \frac{9\text{V}}{8.59 \Omega} = 1.048 \text{ A}$$

Terminal potential difference =

$$IR = 1.048 \text{ A} \times 8.5 \Omega = 8.91 \text{ volt.}$$

Example 6.2 : A battery of emf 2V and internal resistance 0.1Ω is charged with a current of 5A. Find the sense in which current is maintained in the battery. Calculate the T.P.D. between the terminals of the battery.

(I.I.T. 1980)

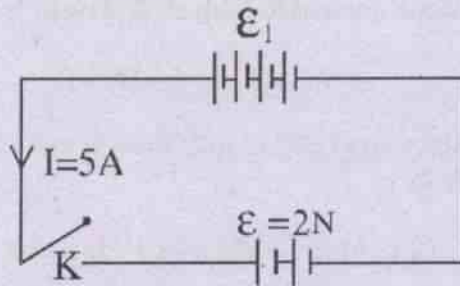

Solution :

The battery to be charged is connected at its +ve terminal to the +ve terminal of another battery called the charging battery or charger. In the circuit diagram of the problem ϵ_1 is the emf of the charger and r is its internal resistance. ϵ ($=2V$) is the emf of the battery which is charged and r_1 is its internal resistance. Then applying Kirchoff's second law to the closed path of the circuit, we have

$$\epsilon_1 = \epsilon + Ir + Ir_1$$

where I is the charging current

$$\Rightarrow \epsilon_1 - Ir_1 = \epsilon + Ir$$

$$\Rightarrow \epsilon_1 - Ir_1 = 2V + 5A \times 0.1 \text{ ohm} = 2.5 V$$

$$\Rightarrow V = \text{Terminal potential difference of the charger}$$

$$= \text{Terminal potential difference of the cell} = 2.5V$$

Here current inside the battery is maintained from its +ve terminal to its negative terminal during charging.

Example 6.3 : In the circuit given below calculate the potential difference between A and B assuming that the batteries have zero internal resistance.

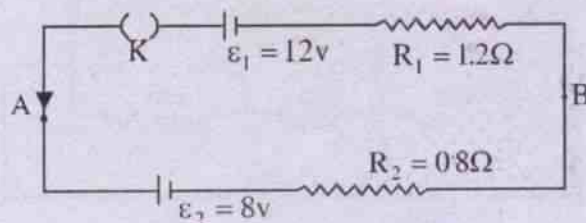

Solution :

When the circuit is closed Kirchoff's second law gives

$$-8V - I \times 0.8\Omega - I \times 1.2\Omega + 12V = 0$$

$$\Rightarrow 4V = I(0.8 + 1.2) \text{ ohm}$$

$$\therefore I = \frac{4V}{2 \text{ ohm}} = 2A$$

\therefore Potential difference between A and B

$$= \epsilon_1 - IR_1 = 12V - 2A \times 1.2\Omega$$

$$= (12 - 2.4) V$$

$$= 9.6 V$$

This is also equal to $\epsilon_2 + IR_2$
 $= 8V + 2A \times 0.8\Omega = 9.6V$

Example 6.4 : Determine the current drawn from a 12V source with internal resistance 0.5Ω , by the following infinite network. Each resistor in the network has a resistance of 1 ohm.

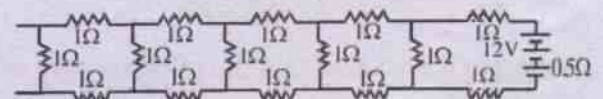

Solution :

Let x be the equivalent resistance of the total external network of the resistors between p & q . Since the chain is infinite the equivalent resistance of the rest of the network to the left between a and b is also x , since the addition or subtraction of one more chain to or from the network keeps its value unaltered. Thus the equivalent circuit of the arrangement is drawn as

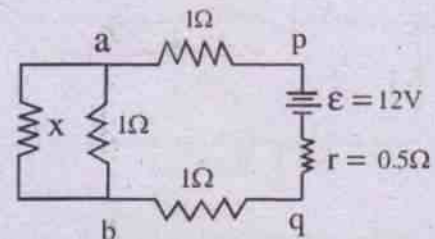

$$\text{Now resistance between } a \text{ and } b = R_1 = \frac{x}{x+1}$$

($\because x \Omega$ and 1Ω are in parallel)

$$\begin{aligned} \therefore \text{Total external resistance} = x &= \frac{x}{x+1} + 2 \\ \Rightarrow x(x+1) &= x + 2x + 2 \\ \Rightarrow x^2 + x &= 3x + 2 \\ \Rightarrow x^2 - 2x - 2 &= 0 \\ \Rightarrow x &= \frac{+2 \pm \sqrt{4+8}}{2} = 1 + \sqrt{3} \text{ and } 1 - \sqrt{3} \end{aligned}$$

$\therefore 1 - \sqrt{3}$ is -ve it is discarded.

$$\therefore x = (\sqrt{3} + 1)\Omega = 2.732\Omega$$

$$\begin{aligned} \therefore \text{Total resistance of the circuit} &= \\ &= (2.732 + 0.5)\Omega \\ &= 3.232\Omega \end{aligned}$$

$$\therefore \text{Current drawn} = \frac{12V}{3.232\Omega} = 3.71A$$

Example 6.5 : Show that the effective emf of the two cells in parallel as given in the circuit diagram below is given by

$$\epsilon_{\text{eff}} = \frac{r_1 r_2}{r_1 + r_2} \left(\frac{\epsilon_1}{r_1} + \frac{\epsilon_2}{r_2} \right)$$

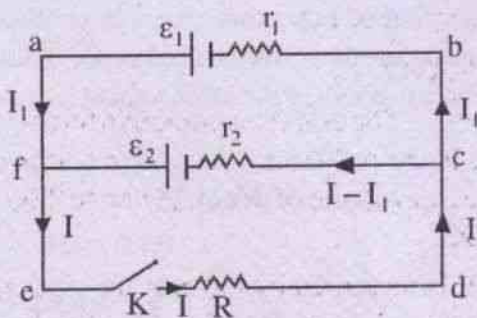

Let the currents in the branch def be I and those in branches ab be I_1 . Then current in fc = $I - I_1$. Applying Kirchhoff's 2nd rule to the loop eabde we have $+\epsilon_1 - I_1 r_1 - IR = 0$... (1)

The same applied to loop efcd gives

$$+\epsilon_2 - (I - I_1) r_2 - IR = 0 \quad \dots (2)$$

Multiplying (1) by r_2 and (2) by r_1 and adding we have

$$(\epsilon_1 r_2 + \epsilon_2 r_1) - IR(r_2 + r_1) - I r_1 r_2 = 0$$

$$\Rightarrow \epsilon_2 r_1 + \epsilon_1 r_2 = I \{ R(r_1 + r_2) + r_1 r_2 \}$$

$$\Rightarrow \frac{\epsilon_1 r_2 + \epsilon_2 r_1}{R(r_1 + r_2) + r_1 r_2} = I$$

$$\Rightarrow I = \frac{\frac{\epsilon_1 r_2 + \epsilon_2 r_1}{r_1 + r_2}}{\frac{R(r_1 + r_2)}{r_1 + r_2} + \frac{r_1 r_2}{r_1 + r_2}} = \frac{\epsilon_e}{R + r_e}$$

where we write $\epsilon_e = \text{effective emf} = \frac{\epsilon_1 r_2 + \epsilon_2 r_1}{r_1 + r_2}$

$$\text{and } r_e = \frac{r_1 r_2}{r_1 + r_2}$$

Thus effective emf

$$\epsilon_e = \frac{\epsilon_1 r_2 + \epsilon_2 r_1}{r_1 + r_2} = \frac{r_1 r_2}{r_1 + r_2} \left(\frac{\epsilon_1 r_2 + \epsilon_2 r_1}{r_1 r_2} \right)$$

$$\Rightarrow \epsilon_e = \frac{r_1 r_2}{r_1 + r_2} \left(\frac{\epsilon_1}{r_1} + \frac{\epsilon_2}{r_2} \right)$$

Example 6.6 : Find the current measured by the ammeter in the circuit shown in the figure given below.

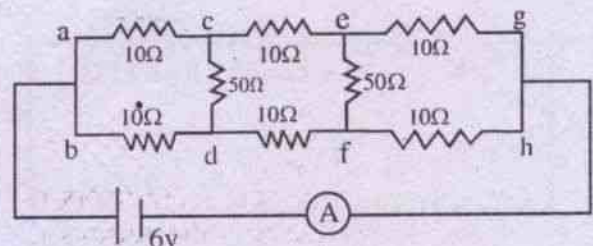

Solution :

Examination of the network of resistors shows that the combination is symmetrical in the two parallel branches a c e g and b d f h.

Considering the combination within the arrangement it is seen that it is equivalent to a balanced wheatstone's bridge in which the potential difference between the points c and d or e and f is zero. Hence the connection of two 50Ω resistors between c and d or between e and f does not influence the circuit current at all. Thus we have two parallel rows of resistances.

$$R_1 \text{ of 1st row i.e. between a and g} = 30\Omega$$

(for 3, 10Ω resistances in series)

$$R_2 \text{ of 2nd row i.e. between b and h} = 30\Omega$$

$\therefore R_1$ and R_2 are in parallel

$$R = \frac{R_1 R_2}{R_1 + R_2} = \frac{30 \times 30}{30 + 30} \Omega = 15\Omega$$

$$\therefore I = \frac{6V}{15\Omega} = 0.4A$$

Example 6.7 : Five equivalent resistors each of 1Ω , are connected in a net work as shown in the circuit given below. Calculate the equivalent resistance between the points A and B.

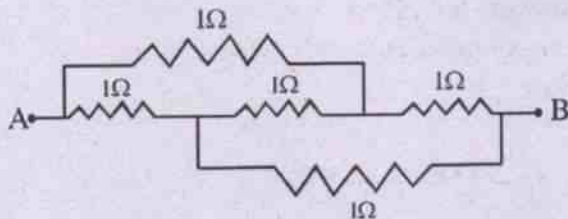

Solution :

The given arrangement of resistors is equivalent to the combination of the resistors as shown in the fig. a, given below.

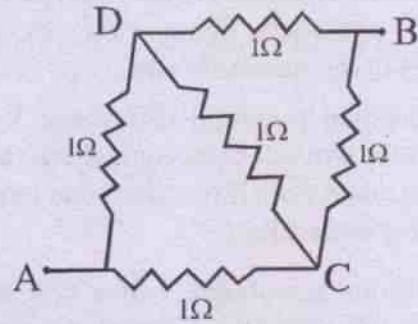

Fig.a

It is a balanced wheatstone's bridge. Hence the points C and D are at the same potential. The 1Ω resistor connected between C and D is totally ineffective. The arrangement is equivalent to Fig. b

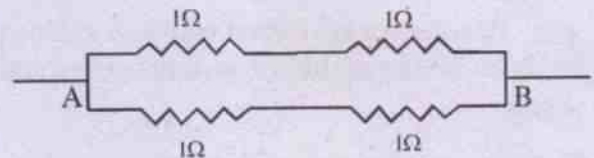

Fig.b

Here two pairs of 1Ω resistors are in parallel, each pair being arranged in series. If the effective resistance between A and B is R, then

$$\frac{1}{R} = \frac{1}{2} + \frac{1}{2}$$

$$\Rightarrow R = 1\Omega$$

SUMMARY

emf : The emf (electromotive force) of a source is the influence of the source to make charges (+ve) move from lower to higher potential.

It is measured by the amount of energy supplied per unit charge to make the charge carriers move completely around a circuit of resistors connected between the terminals of its source.

A source of emf converts some form of nonelectrical energy to electrical in a reversible process. This energy is stored within the source.

Electrochemical batteries, thermocouple, fuel cell, photocell, dynamo etc. are some examples of the sources of emf.

Terminal potential difference V of a source is the work done per unit charge by the source to make them move from one terminal to the other externally.

Internal resistance r of a cell is the resistance offered by the material of the cell to the flow of charges.

The current I in a circuit is related with

$$\mathcal{E}, V, R \text{ and } r \text{ as } I = \frac{\mathcal{E}}{R + r}$$

$$\mathcal{E} - V = Ir$$

Resistances in a circuit may be combined in series or in parallel or in both series and parallel.

For series combination of resistors

$$R = R_1 + R_2 + R_3 + \dots$$

For parallel combination of resistors

$$\frac{1}{R} = \frac{1}{R_1} + \frac{1}{R_2} + \frac{1}{R_3} + \dots$$

A battery is a combination of several cells. When cells are combined in series, the effective emf increases, the current in each cell remaining

the same. It is given by $I = \frac{n\mathcal{E}}{R + nr}$. In parallel combination of cells emf of the circuit is the emf of each cell, current in different cells being different. It is given by

$$I = \frac{n\mathcal{E}}{nR + r}$$

In a mixed grouping of cells, current I is

$$\text{given by } I = \frac{mn\mathcal{E}}{mR + nr}, \text{ where } m \text{ stands for}$$

the no. of rows in parallel and n , the no. of cells in each row.

In mixed grouping of cells current in the circuit becomes maximum when $R_e = r_e$ where R_e stands for the effective external resistance of the circuit and r_e for the effective internal resistance of the cells. Kirchhoff's rules are used to solve for the unknown circuit parameters in complicated network of resistors and cells.

Kirchhoff's first rule : The algebraic sum of currents at any junction of an electrical network of conductors and cells, is zero.

Kirchhoff's second rule : The algebraic sum of emf's around a loop of an electrical network is equal to the algebraic sum of potential drops around it.

A Wheatstone's bridge is an arrangement of four resistors, a cell and a galvanometer to measure the unknown resistance.

The bridge needs to be balanced to measure the unknown resistance using the formula

$$P / Q = R / S$$

A meter bridge and a post office box are two simple practical devices to make a Wheatstone's bridge.

MODEL QUESTIONS**A. Multiple Choice Type Questions :**

1. In a simple d.c. circuit supplying current the emf of a cell is
 - a) always greater than its terminal potential difference.
 - b) always less than its terminal potential difference.
 - c) always equal to its terminal potential difference.
 - d) may be greater than or equal to the terminal potential difference.
2. During charging of a storage cell, its terminal potential difference becomes
 - a) zero
 - b) greater than its emf
 - c) less than its emf
 - d) equal to its emf
3. The phenomenon that works behind the construction of a dynamo is
 - a) thermo electric effect
 - b) magneto mechanical effect
 - c) photo electric effect
 - d) chemical effect.
4. The smallest resistance that one can obtain with five $0.2\ \Omega$ resistors is
 - a) $1\ \Omega$
 - b) $0.5\ \Omega$
 - c) $0.25\ \Omega$
 - d) $0.04\ \Omega$
5. In order to get a resistance of $0.1\ \Omega$, the number of one-ohm resistors to be connected in parallel is
 - a) 1
 - b) 10
 - c) 100
 - d) 1000
6. Three cells each of emf 1.5V and internal resistance $1\ \Omega$ are connected in parallel. The combination will have an emf of
 - a) 4.5V
 - b) 3V
 - c) 1.5V
 - d) 0.5V
7. A primary cell has an emf of 2V . When short circuited, it gives a current of 4A . Its internal resistance is
 - a) $0.5\ \Omega$
 - b) $2\ \Omega$
 - c) $6\ \Omega$
 - d) $8\ \Omega$
8. A wire has a resistance of $12\ \text{ohms}$. It is bent to form a circle. The effective resistance between the ends of any of its diameter is
 - a) $24\ \Omega$
 - b) $12\ \Omega$
 - c) $6\ \Omega$
 - d) $3\ \Omega$
9. Three $2\ \text{ohm}$ resistors are arranged in a triangle. The resistance between any two corners of the triangle is
 - a) $6\ \text{ohm}$
 - b) $2\ \text{ohm}$
 - c) $4/3\ \text{ohm}$
 - d) $3/4\ \text{ohm}$
10. A 50V battery is connected across a $10\ \text{ohm}$ resistor. The current obtained is 4.5A . The internal resistance of the battery is
 - a) zero
 - b) $0.5\ \Omega$
 - c) $1.1\ \Omega$
 - d) $5\ \Omega$
11. Kirchhoff's 1st law is based on the principle of
 - a) conservation of charge
 - b) conservation of energy
 - c) separation of charge
 - d) separation of energy.

12. Three resistors each of resistance $30\ \Omega$ are arranged to form an equilateral triangle. A battery of emf 2V and negligible internal resistance is connected between any two vertices of the triangle. The current delivered by the arrangement is

- a) 0.2 A b) 0.1 A
 c) 0.067 A d) 0.033 A

13. An electric cable of copper has just one wire of radius 9mm . Its resistance is found to be $5\ \Omega$. This single copper wire of the cable is replaced by six different well insulated copper wires each of radius 3mm . The total resistance of the cable now becomes

- a) $7.5\ \Omega$ b) $45\ \Omega$
 c) $90\ \Omega$ d) $270\ \Omega$

14. Five resistances are connected to form a bridge as shown in the circuit diagram given below. The effective resistance between the points A and B is nearly

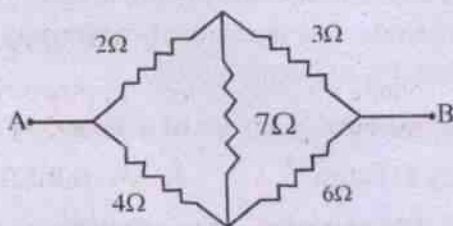

- a) $3.33\ \Omega$ b) $6\ \Omega$
 c) $6.67\ \Omega$ d) $15\ \Omega$

15. A current of 2A enters into the arrangement of resistors given below at A and leaves it at C.

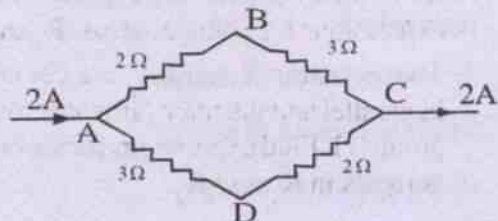

The potential difference between the points B and D i.e. $V_B - V_D$ will be

- a) $+2\text{ V}$ b) $+1\text{ V}$
 c) -1 V d) -2 V

16. Given below is an arrangement of resistors in the form of a wheatstone's bridge.

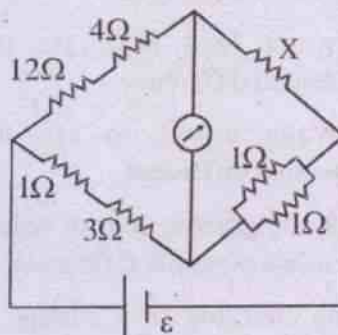

For the bridge to be balanced, the unknown resistance X should be

- a) $4\ \Omega$ b) $3\ \Omega$
 c) $2\ \Omega$ d) $1\ \Omega$

17. Twelve identical resistors each having resistance R are joined to form a skeleton cube. The equivalent resistance between any two diagonally opposite ends will be

- a) 12 R b) 3 R
 c) $6/5\text{ R}$ d) $5/6\text{ R}$

18. A cell having an emf of 3V and negligible internal resistance is connected across a series combination of three resistances of values $3\ \Omega$, $4\ \Omega$ and $5\ \Omega$. The potential difference across the $4\ \Omega$ resistor is

- a) 0.5 V b) 1 V
 c) 1.5 V d) 3 V

19. An electrician has only two resistances. By using them he is able to obtain resistances of $3\ \Omega$, $4\ \Omega$, $12\ \Omega$ and $16\ \Omega$. The two resistances are

- a) $3\ \Omega$ and $13\ \Omega$
 b) $4\ \Omega$ and $12\ \Omega$
 c) $6\ \Omega$ and $10\ \Omega$
 d) $7\ \Omega$ and $9\ \Omega$
20. A total number of 24 cells each of emf 1.5V and internal resistance $0.5\ \Omega$ are combined in mixed grouping to deliver maximum current in an external resistor of $3\ \Omega$. There are m rows of such cells in parallel combination with n cells in series in each row. Then the value of m and n are
- a) $n = 12, m = 2$
 b) $n = 8, m = 3$
 c) $n = 6, m = 4$
 d) $n = 4, m = 6$

B. Very Short Answer Type Questions :

- Define electromotive force (i.e. emf) of a cell.
- Mention the main components of a simple d.c. circuit.
- Can the potential difference across a battery be greater than its terminal potential difference ?
- Does a conductor become charged when a current is passed through it ?
- How will you connect two resistors, each of resistance R to get the maximum current in a circuit of fixed emf ?
- Mention the name of the principle on which is based Kirchhoff's second rule.
- State Kirchhoff's first rule.
- Name the carriers of electric current in a voltaic cell and a lead accumulator.
- Name the carriers of electric current in a solar cell.

- Write down the relation among ε , V , r and R , where the symbols have their usual meaning.
- Define internal resistance of a cell.
- Mention the factor on which the internal resistance of a cell depends.
- A simple chemical cell has an emf of 2V . When the circuit is open what is the difference of potential between its two terminals ?
- Is there a net field which would give rise to a force on a test charge inside the electrolyte of a chemical cell ?
- Name the effect behind the working of a photo cell.
- Name the effect behind the working of a thermo couple.
- Which type of energy is converted to electrical energy in a piezoelectric cell.
- A fuel cell converts _____ type of energy into electrical energy. Fill in the blank.
- Write two factors on which the internal resistance of a cell depends.

[CBSE AI 2010]

- Name the device used for measuring the internal resistance of a secondary cell.

[CBSE 1996]

C. Short Answer Type Questions :

- Explain the action of a source of emf in an electric circuit.
- What is used up in an electric circuit ? Explain.
- Two resistances R_1 and R_2 in series are connected to a source of emf having terminal potential difference V . Find expressions for voltages across R_1 and R_2 .
- Two resistors R_1 and R_2 are connected in parallel and the main current across the group is I . Find expressions for the branch currents in R_1 and R_2 .

5. Although the cost of electric energy from dry cells is high, such sources are widely used. Why?
6. Does a storage cell store up electricity? Explain your answer.
7. Justify that $I\ell = \oint \mathbf{g} \cdot d\mathbf{q}$, where \mathbf{g} is the speed of charges q flowing steadily through a conductor of length ℓ and I is the current in it.
8. Explain the circumstance under which the terminal potential difference of a cell exceeds its emf.
9. When the direction of current in a battery reverses, does the direction of its emf also reverse? Explain.
10. Show that the ratio of voltage drops across two resistors in series is the same as the ratio of their resistances.
11. Show that currents flowing through two resistors in parallel combination are inversely proportional to their resistances.
12. State and explain Kirchhoff's laws in connection with electrical network. (CHSE, 1989 S, 1995, 1996)
13. Distinguish between emf and potential difference. (CHSE 1985 A, 1988 S)
14. Find the effective resistance of two one-ohm resistors connected in parallel. (CHSE, 1990 A)
15. Give a sketch of wheat stone's bridge. (CHSE, 1993 S)
16. The emf of a cell is 12V. In a closed circuit having resistance of 23Ω , it sends a current of 0.5A. What is the internal resistance of the cell? (CHSE, 1994 A)
17. If three cells of emf 6, 9 and 9 volt are connected in parallel, find the output emf. (CHSE, 1994 S)

18. What happens when the two terminals of a cell are connected by a resistance of almost zero value?
19. What is meant by short circuit current?
20. Mention the factors on which the internal resistance of cell, depends.
21. Show that the first rule of Kirchhoff leads to the principle of charge conservation.
22. In a wheat stone's bridge the positions of the battery and the galvanometer are

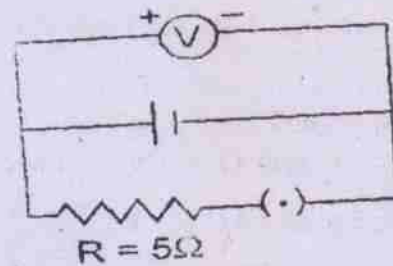

interchanged. Does it affect the balancing condition of the bridge? Explain.

23. Compare and contrast the formulae for the equivalent values of resistance and capacitance when a group of resistors or capacitors are connected in series.
24. Mention the circumstances under which cells are connected in series.
25. Mention the circumstances under which cells are connected in parallel.

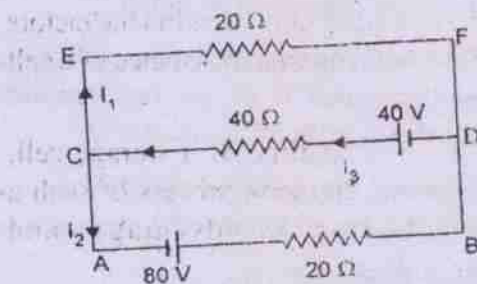

26. State the condition under which the terminal p.d across battery and its emf are equal. [CBSE AI 2004]
27. A car battery is of 12 volt. 8 simple cells connected in series can give 12 volt; but

such cells are not used in starting a car; why? [CBSE Sample Paper]

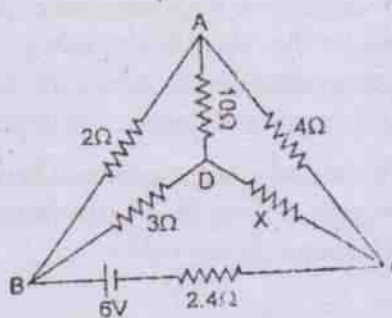

D. Long Answer Type :

1. Explain the meaning of electromotive force and mention its importance in an electrical circuit. Give a brief outline of a

-9-

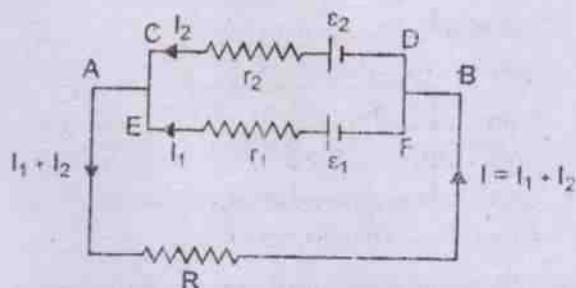

chemical source of emf.

2. Give a brief account of an electrochemical cell. Distinguish between a primary cell and a secondary cell. Mention the factors on which the internal resistance of a cell depends.
3. Give a brief outline of a storage cell. Explain the charging process of such a cell. Mention its advantages and disadvantages.
4. Deduce expressions for the equivalent resistance when a number of resistors are combined (a) in series, (b) in parallel.
5. Deduce an expression for the current supplied by a mixed grouping of cells to an external resistance R . Hence obtain the

condition for maximum current delivered by the combination.

6. State and explain Kirchhoff's laws for an electrical network. Apply them to obtain the condition of balance of a wheatstone's bridge. (CHSE, 1995 S)
7. State and explain Kirchhoff's laws for an electrical network. Apply them to obtain expressions for the equivalent resistance when a number of resistors are connected (a) in series, (b) in parallel.
8. Describe a wheatstone's bridge with a neat circuit diagram and obtain its condition of balance. Mention the importance of such a bridge.

E. Numerical Exercises :

1. The emf of a cell is 12V. In a closed circuit having a resistance of $10\ \Omega$, it sends a current of 1 A. Find the internal resistance of a cell.
2. The potential difference between the terminals of a battery of emf 6V and internal resistance $1\ \Omega$ drops to 5.8V when connected to an external path of resistance R . Find the value of R .
3. An ideal battery sends a current of 5A in a resistor. When another resistor of $10\ \Omega$ is connected in parallel, the current is increased to 6A. Find the resistance of the first resistor.
4. A $10\ \Omega$ resistor and a $20\ \Omega$ resistor are connected in parallel. The combination is connected to a 5.5V cell in one side and a $30\ \Omega$ rheostat in another side. The sliding contact of the rheostat is connected to the other terminal of the battery through an ammeter. Find the maximum and minimum value of current in the circuit. Neglect the internal resistance of the cell.

5. Twelve resistors each of resistance r are joined to form a cube as shown in the figure given below. Find the equivalent resistance between the diagonally opposite points a and f .

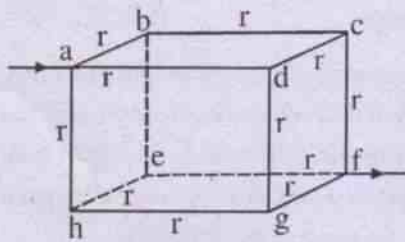

6. Show how four 8 ohm resistors can be connected to provide equivalent resistances of 2Ω , 8Ω , 10.67Ω , 20Ω , and 32Ω .
7. Find the arrangement of 64 identical cells each of internal resistance 1Ω to give a maximum current through an external resistor of resistance 4Ω .
8. Given here is a circuit in which $\epsilon_1 = 2.1V$, $\epsilon_2 = 1.9V$, $R_1 = R_2 = 10\Omega$ and $R_3 = 45\Omega$. Calculate the currents in R_2 and R_3 . Neglect the internal resistances of the batteries.

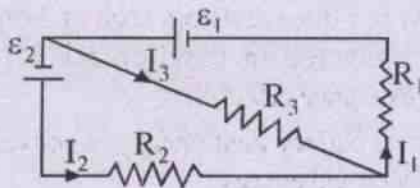

9. In the circuit given below $\epsilon_1 = \epsilon_2 = 2V$, $r_1 = 1\Omega$, $r_2 = 2\Omega$ and $I_1 = 1A$. Find R , I_2 and I_3 in the circuit.

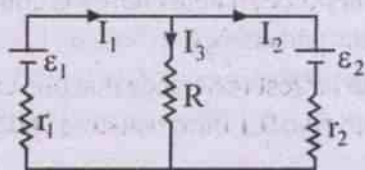

10. Two identical cells each of emf $1.5V$ are joined in parallel. The combination is connected to two 17Ω resistors arranged in parallel. A high resistance voltmeter reads the terminal voltage of the combination of cells to be $1.4V$. Calculate the internal resistance of each cell.
11. Find the equivalent resistance between the points A and B of the network of conductors given below.

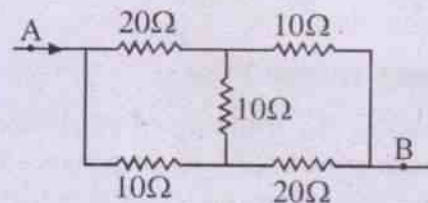

12. Find the equivalent resistance of the network given below between the points a and b .

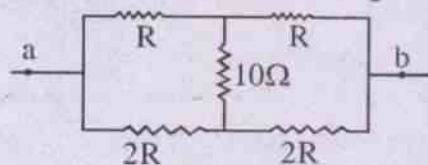

13. Find the effective resistance between the points P and Q in the figure given below.

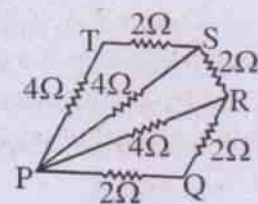

14. Prove that the resistance of the infinite network shown below is equal to $(1 + \sqrt{3})R$ if each resistance in the network is R .

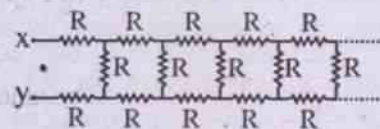

15. The reading of a high resistance voltmeter, when a cell is connected across it, is 2.2 V. When the terminals of the cell are also connected to a resistance of 5Ω , the voltmeter reading drops to 1.8 V. Find the internal resistance of the cell.

[CBSE AI 2010]

16. A battery of emf E and internal resistance r gives a current of 0.5 A with an external resistance of 12Ω and a current of 0.25 A with an external resistance of 25Ω . Calculate (i) internal resistance of the cell and (ii) emf of the cell. [CBSE 2002]
17. Use kirchhoff's laws to determine the value of current I_1 in the electrical circuit given below. [CBSE AI 2007]
18. Find the unknown resistance X , in the following circuit, if no current flows through the section AD. Also calculate the current drawn by the circuit from the battery of emf 6 V and negligible internal resistance. [CBSE 2002]
19. Two cells of emf ε_1 and ε_2 have internal resistance r_1 and r_2 . Deduce an expression for equivalent emf of their parallel combination. [CBSE AI 2008 C]
20. Twelve cells, each of emf 1.5 V and internal resistance 0.5Ω , are arranged in m rows each containing n cells connected in series. Calculate the values of n and m for which this combination would send the maximum current through external resistance of 1.5Ω .

[CBSE Sample Paper]

F. True - False - Type Questions

1. Kirchoff's 1st law is based on the principle of conservation of charge.
2. Kirchoff's 2nd law is based on the principle of conservation of energy.
3. Three resistors each of 1Ω are connected in parallel. The effective resistance is 3Ω .
4. When 25 watt and 100 watt bulbs are

connected in series 25 watt bulb glows brighter.

$$\left[R_1 = \frac{V^2}{P_1} = \frac{V^2}{25}, R_2 = \frac{V^2}{P_2} = \frac{V^2}{100} \Rightarrow R_1 > R_2 \right.$$

$$\left. \therefore I^2 R_1 > I^2 R_2 \right]$$

5. An ordinary battery functions due to chemical reaction within it. C

G. Fill - in - Blank Type Questions

1. Three resistances 2Ω , 3Ω and 6Ω are connected in parallel. The effective resistance is
2. A 50 V battery is connected across a 10Ω resistor. The current obtained is 4.5A. The internal resistance of the battery is
3. A wire of resistance 12Ω is bent to form a circle. The effective resistance between the ends of any of its diameter is
4. A primary cell has an emf of 4V. When short circuited it gives a current of 4A. Its internal resistance is
5. In a battery energy is converted to electrical energy.

H. Correct the following sentences :

1. Kirchoff's 1st law is based on the principle of conservation of energy.
2. When three resistors each of 3 ohm, are connected in parallel, the effective resistance is 9 ohm.
3. In a battery heat energy is converted to electrical energy.
4. When a current flows through a conductor, the conductor gets charged.
5. In a thermo couple chemical energy is converted into electrical energy.
6. In a photocell heat energy is converted to electrical energy.
7. The largest resistance that one can obtain with five 0.1 ohm resistors is 0.5 ohm .

ANSWERS

A. Multiple Choice Type Questions :

1. (d) 2. (b) 3. (b) 4. (d) 5. (b) 6. (c) 7. (a) 8. (d)
 9. (c) 10. (c) 11. (a) 12. (b) 13. (a) 14. (a) 15. (b) 16. (c)
 17. (d) 18. (b) 19. (b) 20. (a)

E. Numerical Problems :

1. 2 ohm
 2. 29 ohm
 3. 2 ohm
 4. $I_{\max} = 0.825\text{A}$, $I_{\min} = 0.15\text{A}$.

5. $\frac{5}{6}r$

6. (i) For 2Ω , All the four connected in parallel. i.e. 

- (ii) For 8Ω , Any one pair in parallel, the two pairs in series i.e. 

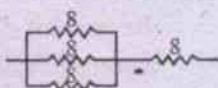
- (iii) For 10.67Ω , Any three in parallel, with the fourth in series, i.e. 

- (iv) For 20Ω , Any two in parallel and the rest in series with it.

- (v) All the four in series.

7. Cells to be combined in 4 rows in parallel with 16 cells in series in each row.
 8. Current I_2 in $R_2 = 0.199\text{A}$, current I_3 in $R_3 = 0.002\text{A}$.
 9. $R = 0.67\text{ohm}$, $I_2 = -0.5\text{A}$, $I_3 = 1.5\text{A}$.
 10. $r = 1.2\text{ohm}$.
 11. 14ohm .
 12. $4R/3$
 13. 2ohm .
 14. Hint - It is an infinite combination. Let the total resistance be S . The net work may be drawn as

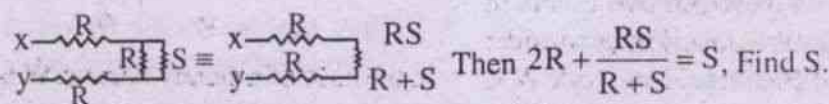

15. 1.1Ω , 16. 1Ω , 6.5V , 17. 1.2A , 18. 6Ω , 1A , 19. $\epsilon = (\epsilon_1 r_2 + \epsilon_2 r_1)/(r_1 + r_2)$.

20. $m=2$, $n=6$

F. (1) True (2) True (3) False (4) True (5) True.

G. (1) 1Ω (2) 1.1Ω (3) 3Ω (4) 1Ω (5) chemical.

7

Thermal And Chemical Effects of Electric Current

In the preceding chapters we have learnt about electric current, the sources which provide it and the circuits or paths in which it is maintained. Electrical energy is supplied through this circuit to different devices where energy conversion from electrical to other forms takes place and work is done. This is exhibited as different effects of electric current such as mechanical, thermal, optical, chemical and magnetic etc. The common devices where such effects are observed include electric fan, electric heater, electric bulb, electric bell, electrolytic cell, electromagnet etc. to name a few. In the present chapter let us discuss about thermal and chemical effects of current mainly, pending discussion on other effects to subsequent chapters. We begin with a discussion on electric energy and power.

7.1 Electric energy and power

When a charge q moves through a potential difference V between two points in an electric field work W is done. Let us consider the simple circuit of Fig. 7.1. Here work W is done by a charge when it moves from A to B.

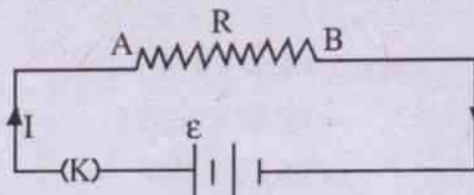

Fig. 7.1

through the resistor R . Since $V_A > V_B$, the charge Δq flowing in time Δt loses energy to R . From the definition of potential difference $V (= V_A - V_B)$, work ΔW done by the charge is written as

$$\Delta W = V \Delta q \quad \dots(7.1.1)$$

If I is the instantaneous current in the circuit

$$\Delta q = I \Delta t$$

$$\text{and } \Delta W = V I \Delta t \quad \dots(7.1.2)$$

When $\Delta t \rightarrow 0$, eq. 7.1.2. is written as

$$dW = V I dt \quad \dots(7.1.3)$$

Hence total work W done by the charges in time 't' is expressed as

$$W = \int_0^t dW = \int_0^t V I dt \quad \dots(7.1.4)$$

In the case of a steady current W is given by

$$W = V I t \quad \dots(7.1.5)$$

This W appears as heat or mechanical energy or light etc depending on the device through which the current is maintained. It represents transformation of electric energy to other forms in a circuit and is transferred to the electrical device connected to it.

When $V_A < V_B$, work is done on the mobile charges which gain energy. Here electric energy is transferred from the circuit elements to the circuit in which these are connected. This happens in the case of charging of a cell.

All electrical devices connected in a circuit have some resistance R . If V is the potential difference between its ends and I , the current through it, then according Ohm's law $V = IR$ and eq. 7.1.5 yields

$$W = V I t = I R \cdot I t = I^2 R t \quad \dots(7.1.6)$$

It can also be written as

$$W = V \cdot \frac{V}{R} t = \frac{V^2 t}{R} \quad \dots(7.1.7)$$

Example 7.1.1 : A 50Ω electric lamp is connected to a 220V line for half an hour. How much energy is drawn from the line ?

$$\text{Here } I = \frac{V}{R} = \frac{220V}{50\Omega} = 4.4 \text{ amp.}$$

$$\therefore W = I^2 R t = (4.4 \text{ amp})^2 \times 50 \text{ ohm} \times 30 \times 60 \text{ sec}$$

$$= 1.74 \times 10^6 \text{ Joules}$$

Electric Power

The time rate of spending electric energy is called electric power P . The instantaneous power in a circuit is expressed mathematically as

$$P = \frac{dW}{dt} = VI \quad \dots(7.1.8)$$

(from eq. 7.1.3)

$$\text{It can also be written as } P = I^2 R \quad \dots(7.1.9)$$

$$\text{and } P = \frac{V^2}{R} \quad \dots(7.1.10)$$

When electric work is done over an interval of time t and current I is not steady, the average power during the interval is given by

$$\bar{P} = \frac{W}{t} = \frac{\int_0^t VI dt}{t} \quad \dots(7.1.11)$$

where W is the total work done during time t . In the case of steady current the average power is equal to the instantaneous power spent by the source of emf.

Units and dimension of power

The S.I. unit of power is watt which is abbreviated as W. From eq. 2.3.7

$$1 \text{ watt} = 1 \text{ volt} \times 1 \text{ amp.}$$

$$= 1 \text{ volt} \times 1 \frac{\text{coul}}{\text{sec}}$$

$$= 1 \frac{\text{joule}}{\text{coul}} \cdot \frac{\text{coul}}{\text{sec}}$$

$$= 1 \text{ Joule / Sec}$$

$$\text{i.e. } 1 \text{ W} = 1 \text{ J/S}$$

Since watt is a small unit of power, its higher multiples like kilowatt (KW), Megawatt (MW), Horse power (HP) etc. are used as its practical units.

$$1 \text{ KW} = 1000 \text{ W} = 10^3 \text{ W}$$

$$1 \text{ MW} = 1000000 \text{ W} = 10^6 \text{ W}$$

$$1 \text{ HP} = 746 \text{ W}$$

1 HP is actually the practical unit of power in British thermal units and often used for commercial purposes.

Kilo Watt Hour (KWH)

When any electrical device designed to draw 1 KW of power is operated continuously for 1 hour, the electrical energy consumed is called 1 kilowatt Hour or 1 KWH.

$$1 \text{ KWH} = 1 \text{ KW} \times 1 \text{ H}$$

$$= 10^3 \text{ W} \times 3600 \text{ S}$$

$$= 3.6 \times 10^6 \text{ WS}$$

$$= 3.6 \times 10^6 \text{ J}$$

1 KWH is also called one B. O. T. (Board of Trade) unit. It is used as 1 unit of electrical energy consumed in households, factories and institutions and the cost of electricity is charged according to the number of such units consumed per month. The meters fixed in our houses directly read the number of units consumed so that

The cost = No. of units x Cost per unit

Example 7.1.2 : Calculate the cost of electric energy if a person uses an electric lamp drawing power from a 250V mains which supplies energy at 1 A for the month of April, the lamp being lighted for 8 hours every day. The cost of electricity is Rs.2/- per unit.

Amount of energy consumed

$$= VIt$$

$$= 250V \times 1A \times 8 \times \frac{\text{hours}}{\text{day}} \times 30 \text{ days}$$

$$= 250 \text{ W} \times 8 \times 30 \text{ hours}$$

$$= 60000 \text{ watt hours}$$

$$= 60 \text{ KWH} = 60 \text{ units.}$$

$$\therefore \text{cost} = \text{Rs. } 2.00 \times 60 = \text{Rs. } 120/-$$

Maximum Power Theorem

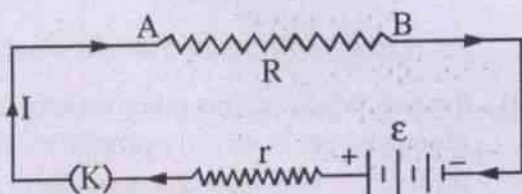

Fig. 7.2

Fig 7.2 shows a simple electric circuit where R and r are the external load resistance and the effective internal resistance of the battery respectively. On closing the key K, current I is maintained in the circuit. It is given by

$$I = \frac{\epsilon}{R+r}$$

Where ϵ represents the effective emf of the battery.

The Power dissipated in the load resistor

$$R \text{ is given by } P = I^2R = \frac{\epsilon^2 R}{(R+r)^2} \quad \dots 7.1.12$$

We may write eq. 7.1.12 as

$$P = \frac{\epsilon^2}{\left(\frac{R}{\sqrt{R}} + \frac{r}{\sqrt{R}}\right)^2}$$

$$= \frac{\epsilon^2}{\left(\sqrt{R} - \frac{r}{\sqrt{R}}\right)^2 + 4\sqrt{R} \cdot \frac{r}{\sqrt{R}}}$$

$$\Rightarrow P = \frac{\epsilon^2}{\left(\sqrt{R} - \frac{r}{\sqrt{R}}\right)^2 + 4r} \quad \dots 7.1.13$$

In 7.1.13 Power P is maximum if the denominator in the R.H.S. is minimum and it happens when

$$\left(\sqrt{R} - \frac{r}{\sqrt{R}}\right)^2 = 0$$

$$\text{or } \sqrt{R} = \frac{r}{\sqrt{R}}$$

$$\text{or } R = r$$

Thus it is seen that a circuit consumes maximum power when its external resistor has a resistance same as the effective internal resistance of the cell. The expression for maximum power then becomes

$$P_{\max} = \frac{\epsilon^2}{4r} \text{ or } \frac{\epsilon^2}{4R} \quad \dots 7.1.14$$

7.2 Heating effect of electric current

When a conductor is connected to the source of emf in a circuit, an electric field is established within the conductor. The charge carriers which are free electrons in case of a metallic conductor, get accelerated in the field and gain kinetic energy. But it is lost very soon because of their collisions with the lattice ions and impurities of the conductor. They suffer a number of such collisions before attaining drift velocity and in every collision some energy is lost within the conductor so that its internal energy increases gradually. It appears in the form of heat which is called **Joule heat**.

Let us consider the circuit given in Fig. 7.2. It is assumed that there is negligible energy loss in the connecting wires of the circuit and the source provides a steady emf so that when the key is closed a steady current I is established in the circuit. It is because of the motion of free electrons within the conductor from B to A and also within the connecting wires. It is equivalent to the motion of positive charge carriers in the sense from A to B.

Let us take the terminal potential difference (TPD) of the source to be V which is the potential difference between the ends of the resistor R . Considering the motion of a small charge dq in infinitesimal time dt along AB, the work done by it against R is given by

$$dW = V dq = VI dt \quad \dots(7.2.1)$$

($\because dq = I dt$.)

\therefore Total work done by the charge carriers within time t is given by

$$W = \int_0^w dW = \int_0^t VI dt = VI t \quad \dots(7.2.2)$$

$\therefore V = IR$, we may write

$$W = IR \cdot It = I^2 R t \quad (7.2.3)$$

This work done by the charge carriers appears as heat in the resistor. Considering the equivalence of work and heat we may write

$$W \propto Q$$

$$\text{or } W = JQ \quad \dots(7.2.4)$$

where J is a constant known as the mechanical equivalent of heat.

When Q is measured in joules $J=1$ so that

$$Q = W = I^2 R t \text{ joules of heat.}$$

When Q is measured in calories $J = 4.19$ joule per calorie so that

$$Q = \frac{W}{J} = \frac{I^2 R t}{J} \text{ calories} \quad \dots(7.2.5)$$

It follows from 7.2.5 that

(i) the heat produced in a given resistor in a given time is directly proportional to the square of current in it.

i.e. $Q \propto I^2$ (when R and t are constants)

(ii) the heat produced in a resistor by a given current in a given time is directly proportional to the resistance for which the current exists in it.

i.e. $Q \propto R$ (when t and I are constants)

(iii) the heat produced in a given resistor by a given current is directly proportional to the time for which current is passed in the resistor.

i.e. $Q \propto t$ (when I and R are constants)

The heating effect of electric current was studied experimentally by **James Prescott Joule** and the laws stated above were given by him basing on his experimental results. Later these could be deduced theoretically. Hence these laws are known as **Joule's laws of heating**.

Experimental verification of Joule's laws of heating

The experimental arrangement is shown in Fig. 7.3. The apparatus consists of a copper calorimeter C insulated from the surroundings by box B. A heating coil of resistance R is connected at its two ends with a circuit consisting of a battery ϵ , key K, a rheostat Rh and an ammeter A, all in series. A voltmeter V is connected at the two ends of the coil in parallel with it. The calorimeter is covered by a lid L made of insulating material. Provisions are made to insert a thermometer T and a stirrer S into the contents of the calorimeter through its lid. About three fourth of the copper calorimeter is filled with water and its initial temperature is recorded. By adjusting the rheostat, a given current I is passed for a given time t. The readings of the ammeter and the voltmeter, and the final temperature of water and calorimeter are recorded at the end. Care is taken to see that current value remains constant during any given interval.

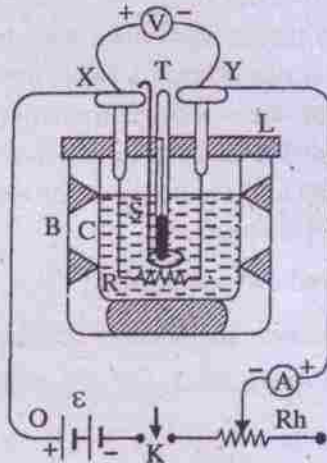

Fig. 7.3 Arrangement for verification of Joule's heating law

The heat produced by the coil is given by

$$Q = \frac{VIt}{J} = \frac{I^2Rt}{J} \quad \dots 7.2.6$$

where V, I and t stand for the voltmeter reading

in volt, the ammeter reading in ampere and time in sec respectively. J stands for mechanical equivalent of heat in joules per calorie and R for the resistance of the heating coil.

The heat Q gained by the calorimeter and its contents during time t is also given by

$$Q = (ms + m_w)(\theta_2 - \theta_1) \quad \dots 7.2.7$$

Here m stands for mass of the calorimeter and stirrer and s for the specific heat of its material. θ_1 and θ_2 stand for the initial and the final temperatures respectively recorded by the thermometer. m_w is the mass of water taken inside the calorimeter.

(a) Verification of 1st law (the law of current)

If two different currents are passed through the contents of the calorimeter for the same time interval in the same coil

$$\frac{Q_1}{Q_2} = \frac{I_1^2}{I_2^2} \quad \text{from } \dots 7.2.6$$

If θ_1, θ_2 and θ_3, θ_4 are the initial and final temperature pairs for the currents I_1 and I_2 respectively maintained for the same time, then

$$\frac{Q_1}{Q_2} = \frac{\theta_2 - \theta_1}{\theta_4 - \theta_3} \quad \text{from } \dots 7.2.7$$

If 1st law is correct one gets

$$\frac{I_1^2}{I_2^2} = \frac{\theta_2 - \theta_1}{\theta_4 - \theta_3}$$

(b) Verification of second law (the law of resistance)

The same current is passed for the same interval through the contents of the calorimeter separately by connecting two coils of resistances R_1 and R_2 which are measured from the ammeter and voltmeter readings. As before if θ_1, θ_2 and θ_3, θ_4 are the initial and final temperature pairs for the two separately, then one would get

$$\frac{R_1}{R_2} = \frac{\theta_2 - \theta_1}{\theta_4 - \theta_3}$$

Using the experimental values if this relation is verified, then the second law is correct.

(c) **Verification of third law (the law of time)**

The same current is passed through the same coil for two different intervals t_1 and t_2 . Let θ_1 be the temperature at the beginning, θ_2 , the temperature at the end of 1st interval and θ_3, θ_4 be the corresponding temperatures at the end of second interval. Then one gets from the relations 7.2.6 and 7.2.7 that

$$\frac{t_1}{t_2} = \frac{\theta_2 - \theta_1}{\theta_4 - \theta_3}$$

Putting the experimental values of $t_1, t_2, \theta_1, \theta_2$ and θ_3 if the above relation is found to be correct, the third law is verified.

7.3 Heating effect in different Conductors

Let us recall the power eq. 7.1.10 i.e.

$P = \frac{V^2}{R}$. Since $R = \frac{\rho \ell}{A}$ (the symbols having their usual meanings) one gets

$$P = \frac{V^2 A}{\rho \ell} \quad \dots 7.3.1$$

This shows that for a given potential difference across R , the power dissipated in the resistor depends on

- (1) the area of cross section A of the resistor
i.e. $P \propto A$ (ρ, ℓ being kept constant)
- (2) the resistivity of the material of the resistor
i.e. $P \propto \frac{1}{\rho}$ (A and ℓ being constant)

- (3) the length of the resistor

i.e. $P \propto \frac{1}{\ell}$ (A and ρ being constant)

For high rate of heat production, the conducting wire should have larger area of cross section, smaller length and lower resistivity. Moreover it should have high melting point to withstand high temperature. Wires made of materials like Nichrome or Molybdenum satisfy such conditions and hence are used in electric furnaces.

Such heating effect of electric current in conductors is used in making many house hold electrical appliances, like electric bulb, electric iron, electric stove, soldering iron, water heater, room heater and fuse etc.

Electric fuse

It is a device for protecting costly electric appliances from damage because of heating effect due to excess current. It is usually made of a conducting wire of copper or tin or lead or an alloy of lead and tin (75%, 25%). It is connected in series with the apparatus to be protected so that it acts as a cutout because it melts when strongly heated. Fuses are designed for maximum safe working current or the fusing current. When the current is more than the rated value it melts and the circuit is broken before the apparatus is damaged.

Some worked out examples

Ex. 7.1 Calculate the highest voltage one can safely put across a $98 \Omega, 0.5 \text{ W}$ resistor ?

Soln.

Given, $R = 98 \Omega$ and $P = 0.5 \text{ W}$

$$\begin{aligned} \therefore P &= \frac{V^2}{R} \\ \therefore V^2 &= PR \\ &= 0.5 \text{ W} \times 98 \text{ ohm} \\ &= 49 \text{ (volt)}^2 \\ \therefore V &= 7 \text{ volt.} \end{aligned}$$

Ex. 7.2 A dry cell of emf 1.5 V and internal resistance 0.1Ω is connected across a resistor in series with an ammeter of very low resistance. When switched on, the ammeter reading settles to a steady value of 2A. Calculate (a) the rate of chemical energy extracted from the cell, (b) the rate of energy dissipation inside the cell (c) the rate of dissipation of energy in the resistor and (d) the power output.

Soln.

$$\text{Given that } \varepsilon = 1.5\text{V}$$

$$r = 0.1\Omega$$

$$I = 2\text{A}$$

- \therefore (a) rate of chemical energy extracted from the source = $\varepsilon I = 1.5\text{ V} \times 2\text{A} = 3\text{ W}$.
- (b) rate of energy dissipation inside the cell = $I^2 r = 4\text{A}^2 \times 0.1\Omega = 0.4\text{W}$.
- (c) rate of dissipation of energy in the resistor = $\varepsilon I - I^2 r = 3\text{W} - 0.4\text{W} = 2.6\text{W}$.
- (d) The power output = rate of dissipation of energy in $R = 2.6\text{W}$.

Ex. 7.3 If a charge of 20 coulomb flows across a potential difference of 220 V maintained between the ends of a resistor how much work is done? How much heat is generated?

Soln.

$$\text{Given } q = 20\text{ C}$$

$$V = 220\text{ V}$$

$$\therefore W = Vq = 220\text{ V} \times 20\text{ C} = 4400\text{ J}$$

$$\therefore Q = \frac{W}{J} = \frac{4400\text{ J}}{4.19\text{ J/Cal}} = 1050\text{ Cal.}$$

Ex. 7.4 A bulb rated as 100 W, 220 V is connected across 110 V line during low voltage. Calculate the power consumed by the bulb.

Soln.

The actual resistance of the bulb

$$R = \frac{V^2}{P} = \frac{(220\text{V})^2}{100\text{W}}$$

$$= \frac{220 \times 220}{100} \Omega = 484\text{ ohm}$$

When connected across 100 V line

$$P' = \frac{V'^2}{R} = \frac{110 \times 110\text{ Volt}^2}{484\text{ ohm}}$$

$$= 25\text{ W.}$$

Ex. 7.5 An electric motor operating at a 50 V d.c. supply draws a current of 12 A. If the efficiency of the motor is 30%, calculate the resistance of its windings.

Soln.

$$\text{Given } V = 50\text{ V}$$

$$I = 12\text{ A}$$

$$\eta = 30\%$$

$$\text{Input power} = VI = 50\text{ V} \times 12\text{ A} = 600\text{ W} = P_i$$

$$\eta = \frac{\text{out put power}}{\text{input power}} = \frac{30}{100}$$

$$\Rightarrow \text{Out put power} = \frac{3}{10} \times \text{Input power}$$

$$= \frac{3}{10} \times 600\text{W} = 180\text{W} = P_o$$

$$\therefore \text{Loss of power} = 600\text{ W} - 180\text{ W} = 420\text{ W.}$$

= the power dissipated in the resistor

$$\therefore \text{Power dissipated} = I^2 R$$

$$R = \frac{\text{Power dissipated}}{I^2} = \frac{420\text{ W}}{12 \times 12\text{ A}^2}$$

$$= 2.92\Omega$$

Ex. 7.6 A battery of emf 6.24 V has an internal resistance of 0.105 ohm. The battery is to be

charged for one day with a current of 5.18 A from a source that maintains a potential difference of 12.65 volts. Calculate

- the heat developed in the rheostat that must be included in the circuit,
- the energy supplied by the source,
- the energy converted into chemical energy.

Soln.

The circuit diagram of the arrangement is given below.

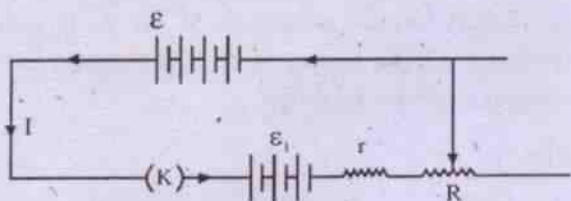

The battery of emf ε is the charging battery and the battery of emf ε_1 is to be charged. R is the resistance of the rheostat. r is the internal resistance of ε_1 .

Given that Charging current $I_1 = 5.18$ A

Terminal potential diff. of $\varepsilon = 12.65$ Volt

Here we have $V = \varepsilon_1 + Ir + IR$
(As the battery is being charged)

$$\therefore \frac{(V - \varepsilon_1)}{I} - r = R$$

$$\Rightarrow R = \frac{(12.65 - 6.24)V}{5.18A} - 0.105\Omega = 1.133\Omega$$

(a) \therefore Heat developed in the rheostat = $\frac{I^2 R t}{J}$

$$= \frac{(5.18A)^2 \times 1.133\Omega \times 24 \times 3600S}{4.2 \text{ J/cal}}$$

$$= 6.254 \times 10^5 \text{ cal.}$$

(b) Energy supplied by the source = VIt
 $= 12.65 \text{ V} \times 5.18 \text{ A} \times 24 \times 3600 \text{ S}$
 $= 5.66 \times 10^6 \text{ J.}$

(c) Energy converted into chemical energy of ε_1

$$= \varepsilon_1 It = 6.24 \text{ V} \times 5.18 \text{ A} \times 24 \times 3600 \text{ S}$$

$$= 2.79 \times 10^6 \text{ J.}$$

7.4 Chemical effect of electric current, Electrolysis

Several liquids like solutions of inorganic salts in water, dilute acids and bases are found to be good conductors of electricity. Chemical reaction takes place when electric current is maintained through such liquids which are known as electrolytes. A vessel with the electrolyte is called an electrolytic cell or voltameter. The mechanism of electric conduction in electrolytes is quite different from that in metals. Such conductivity of the medium is due to the motion of both positive and negative ions into which the compound breaks up. *The separation of positive and negative ions in the chemical reaction brought about by electric current through the conducting solution is called electrolysis.*

Two conducting plates through which the current enters and leaves the electrolyte are called the **electrodes**. These are placed within the electrolytic cell and are externally connected to the electric circuit. Such a circuit containing a voltmeter is shown in Fig. 7.4. It is a Copper voltameter as the electrolysis of copper sulphate (CuSO_4) solution is carried out in it. Some such other voltmeters are Silver voltameter, Water voltameter etc.

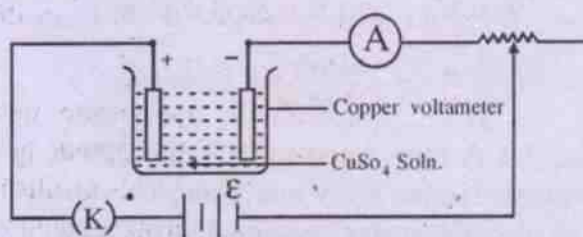

Fig. 7.4

The electrode of the voltmeter connected to the positive terminal of the source of emf is called **anode** and that connected to the negative terminal is called **cathode**. Electric current enters the solution through the anode and leaves it through cathode.

With passage of electricity through the electrolyte, it breaks up into positive and negative ions which move respectively towards cathode and anode. Hence the +ve ions are called cations and the -ve ions the anions. When these ions come to their respective electrodes the following processes may occur.

- (i) Some of the ions may be discharged and the electrons are transferred between ions and electrodes.
- (ii) Fresh ions may be formed from the material of the electrode and go into solution.

For example in a copper voltmeter connected in the circuit given in Fig. 7.4, the Copper Sulphate solution undergoes dissociation into Cu^{++} ions and SO_4^- ions. When the circuit is switched on, the Cu^{++} ions move to the cathode which is a copper plate. There each copper ion receives two electrons from the cathode and gets deposited on it as a copper atom.

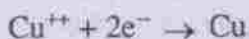

The SO_4^- (Sulphate) ions move to the anode which is also a plate of copper. Here each SO_4^- ion reacts with one copper atom of the plate and forms a CuSO_4 molecule which is liberated into the electrolyte. In the process two electrons are made available to move in the circuit. $\text{Cu} + \text{SO}_4^- \rightarrow \text{CuSO}_4 + 2e^-$.

Thus copper from the anode gets dissolved whereas copper at the cathode gets deposited on the cathode plate. This results in (i) no change in the concentration of the solution, (ii) loss of weight of the anode plate and (iii) gain in weight of the cathode plate. This process

is utilized in purifying copper; where the anode is made up of a block of impure copper and the cathode, a thin sheet of pure copper.

In some Copper voltmeters platinum electrodes are used instead of copper electrodes. When electrolysis is carried out, copper from CuSO_4 solution is deposited at the cathode whereas oxygen is liberated at the anode. In such a voltmeter the strength of copper sulphate solution gradually decreases as more and more electrolysis is carried out.

7.5 Faraday's laws of electrolysis

The first quantitative study of electrolysis was made by Michale Faraday who formulated two laws basing on his experimental results. These are known as Faraday's laws of electrolysis.

First Law

The mass of any substance liberated at an electrode during electrolysis is proportional to the quantity of charge that passes through the electrolyte during the period.

Mathematically $m \propto q$

$$\text{i.e. } m = Zq. \quad \dots(7.5.1)$$

Here m is the mass of the substance liberated and q is the quantity of charge that flows in time t . If the steady current maintained in the circuit is I , then $q = It$, so that from eq. 7.5.1.

$$m = Z I t \quad \dots(7.5.2)$$

In 7.5.1 and 7.5.2 Z is the constant of proportionality which depends on the nature of the substance that is liberated. It is called the "Electro Chemical Equivalent" (E.C.E.) of the substance. Clearly

$$Z = \frac{m}{q} = \frac{m}{It} \quad \dots(7.5.3)$$

Thus E.C.E. of a substance is defined as the mass of the substance liberated during electrolysis per unit quantity of charge i.e. due to unit current maintained per unit time. Clearly

the unit of E.C.E. i.e. $Z = \text{kg/coul}$ in S.I. system. Its dimension is given as $M^1 A^{-1} T^{-1}$. The values of E.C.E. of some substances along with some other useful data are given in table 7.1.

TABLE 7.1

Electro chemical data of some elements

Elements	Atomic mass m_A	Valence v	Chemical Equivalent (c)	Electro Chemical Equivalent (Z) (kg/coul)
Aluminium (Al)	27.1	3	9.033	9.36×10^{-8}
Copper (Cu)	63.6	2	31.8	32.94×10^{-8}
Gold (Au)	197.2	3	65.733	68.12×10^{-8}
Hydrogen (H)	1.008	1	1.008	68.12×10^{-8}
Iron (Fe)	55.8	3	18.6	19.29×10^{-8}
Iron (Fe)	55.8	2	27.9	28.94×10^{-8}
Lead (Pb)	207.2	2	103.6	107.36×10^{-8}
Nickel (Ni)	58.68	2	29.34	30.41×10^{-8}
Oxygen (O)	16.00	2	8	8.29×10^{-8}
Silver (Ag)	107.88	1	107.88	111.8×10^{-8}
Zinc (Z)	63.38	2	31.69	33.87×10^{-8}

Second Law

When the same quantity of charge is passed through different electrolytes, the mass of different substances liberated at the respective electrodes is directly proportional to chemical equivalents.

Mathematically $m \propto c$

where c stands for the chemical equivalent of the substance and is given by the ratio of its atomic weight and valency. If m_1 and m_2 are the masses of two substances liberated during electrolysis by the same quantity of charge and c_1 and c_2 are their chemical equivalents respectively, then from the second law

$$\frac{m_1}{m_2} = \frac{c_1}{c_2} \quad \dots(7.5.4)$$

For example if the same current is passed for the same time through solutions of CuSO_4 , AgNO_3 and acidulated water, then for every one gram of hydrogen liberated during electrolysis, 108 gm of silver and 31.8 gm of Copper will be liberated at their respective electrodes.

Combination of the two laws, Faraday Constant

If m_1 and m_2 are masses of two substances liberated during electrolysis by the passage of the same quantity of charge q , then from eq. 7.5.1

$$\frac{m_1}{m_2} = \frac{Z_1}{Z_2} \quad \dots(7.5.5)$$

Here Z_1 and Z_2 stand for the E.C.E.'s of substances 1 and 2 respectively. Combining this equation with eqn. 7.5.4, we may write

$$\frac{m_1}{m_2} = \frac{Z_1}{Z_2} = \frac{c_1}{c_2} \quad \dots(7.5.6)$$

$$\Rightarrow \frac{c_1}{Z_1} = \frac{c_2}{Z_2} = \frac{c_3}{Z_3} \dots \text{etc.}$$

It thus implies that $\frac{c}{Z}$ for any substance is a constant

$$\text{i.e. } \frac{c}{Z} = F \quad \dots(7.5.7)$$

where F is called the **Faraday Constant**. Since it is true for any substance it may be regarded as a Universal Constant like the Universal gas constant or Universal gravitational constant. This can immediately be verified using table 7.1.

The calculated value of $F = \frac{c}{Z}$ comes to be around

$$9.6539 \times 10^7 \text{ coul/kg for Copper}$$

$$9.6494 \times 10^7 \text{ coul/ kg for Silver}$$

$$9.6 \times 10^7 \text{ coul/kg for Hydrogen}$$

and $9.65 \times 10^7 \text{ coul/kg for Oxygen etc.}$

Experimentally the value of F has been found to be $9.64867 \times 10^7 \text{ coul/kg}$ which very nearly tallies with the different calculated values.

The universally accepted value of $F = 9.65 \times 10^7 \text{ coul per kg equivalent.}$

It means that a charge of $9.65 \times 10^7 \text{ coul.}$ will liberate or dissolve 1.008 kg of hydrogen, 107.88 kg of silver or 31.8 kg of copper etc.

Since the kg equivalent of any substance is equal to 1 kilomole or 10^3 mole of the substance, the Faraday constant is defined as the amount of charge capable of liberating or dissolving 1 kilomole of monovalent substance

during electrolysis. It thus comes to be 96500 coul. per mole and is taken as one bigger unit of the quantity of charge i.e. **Faraday**. Since one mole contains Avagadro's number of atoms or molecules or ions as the case may be, we may write

$$F = N_A e \quad \dots(7.5.8)$$

where N_A is the Avagadro's number and e is the electronic charge. Therefore one Faraday of charge is calculated as

$$\begin{aligned} 1 \text{ Faraday} &= 6.023 \times 10^{23} \text{ electrons} \times e \\ &= 6.023 \times 10^{23} \text{ electron} \times \\ &\quad 1.602 \times 10^{19} \text{ coul/ electron} \\ &\approx 9.65 \times 10^4 \text{ coul.} \\ &= 96500 \text{ coul.} \end{aligned}$$

From eq. 7.5.8 it follows that for monovalent ions charge carried by 1 mole of ions = $1F \text{ coul}$; for divalent ions charge carried by 1 mole of ions = $2F \text{ coul}$ and so on. It confirms the atomicity in electricity.

7.6 Some applications of electrolysis

(a) Electroplating

It is the process of depositing one layer of a metal like nickel, chromium, silver or gold over another material by electrolysis. The material to be electroplated must be conducting and is used as cathode and the metal to be deposited is used as anode. A solution of the salt of the metal to be deposited is used as the electrolyte.

For example in electroplating silver on a copper spoon, a silver rod is used as anode, a copper spoon is used as the cathode and the silver nitrate solution is taken as the electrolyte.

Using similar process zinc is deposited on iron sheets to prevent it from oxidation.

(b) Purification of metals

Metals such as copper, gold, silver etc. are purified by the process of electrolysis. Here

the impure metal is made the anode and pure metal is made the cathode. The solution of a given salt of the metal is taken as the electrolyte and electrolysis is done.

(c) Decomposition of chemical compounds

A chemical compound which can conduct electricity is decomposed into its constituent elements by electrolysis.

(d) Extraction of metals

Some metals like aluminium silver, gold etc. are extracted from their ores by the process of electrolysis.

(e) Callibration of an ammeter

Since a given quantity of charge can deposit a fixed quantity of a substance in the process of electrolysis, the current in a circuit used for electrolysis can be measured by measuring the mass of substance deposited, the E.C.E. of the substance and the time of electrolysis. The calculated value of current is compared with the reading of the ammeter connected in the circuit and thus it is callibrated.

Some worked out examples

Ex. 7.7 Calculate the quantity of hydrogen liberated each day in an acidulated water voltameter in which a constant current of 30 A is maintained. (Z of hydrogen = 1.05×10^{-8} kg/coul)

Soln.

$$\text{Given } I = 30 \text{ A}$$

$$t = 24 \times 3600 \text{ Sec.}$$

$$\begin{aligned} \therefore m &= ZIt = 1.05 \times 10^{-8} \text{ kg/coul} \times 30 \text{ A} \times 24 \\ &\quad \times 36 \times 10^2 \text{ S} \\ &= 0.027216 \text{ kg} \\ &\approx 27.2 \text{ gram.} \end{aligned}$$

Ex. 7.8 A current of 2A is maintained in two coulombmeters in series. One is of silver and the other is an unknown metal of atomic mass 55. In 2 hrs. 2.73 gm of the unknown metal is

deposited at its electrode. Calculate the amount of silver deposited and the valency of the unknown metal ($Z_{\text{Ag}} = 111.8 \times 10^{-8}$ kg/coul)

Soln.

$$I = 2 \text{ A}$$

$$t = 2 \times 3600 \text{ S} = 7200 \text{ S}$$

$$\text{mass of unknown metal} = m = 2.73 \text{ gm}$$

For the unknown metal $m = ZIt$

$$\begin{aligned} \Rightarrow Z &= \frac{m}{It} = \frac{2.73 \text{ gm}}{2 \text{ A} \times 7200 \text{ S}} \\ &= 1.89583 \times 10^{-7} \text{ kg/c} \end{aligned}$$

$$\begin{aligned} \text{Mass of silver deposited} &= m_{\text{Ag}} = Z_{\text{Ag}} It \\ &= 0.16099 \text{ kg} \\ &= 16.1 \text{ gm} \end{aligned}$$

$$\therefore \frac{c}{c_{\text{Ag}}} = \frac{Z}{Z_{\text{Ag}}}$$

$$\therefore c = \frac{Z}{Z_{\text{Ag}}} \times c_{\text{Ag}} = \frac{1.89583 \times 10^{-7} \text{ kg/c}}{111.8 \times 10^{-8} \text{ kg/c}} \times \frac{107.88}{1}$$

$$\Rightarrow c = 18.2936 = \frac{m_A}{v}$$

where m_A = atomic mass

v = valency of unknown metal

$$\therefore v = \frac{m_A}{c} = \frac{55}{18.2936} = 3.007 \approx 3$$

Ex. 7.9 A copper voltameter is connected in series with a coil of resistance 100Ω . A steady current is passed through the circuit for 10 minutes and it deposits 0.1 gm of copper. Calculate the heat generated in the coil. E.C.E. of copper = 32.94×10^{-8} kg/coul.

Soln.

$$\text{Given } t = 10 \text{ min} = 600 \text{ S}$$

$$m_{\text{cu}} = 0.1 \text{ gm.} = 0.0001 \text{ kg}$$

$$Z_{\text{Cu}} = 32.94 \times 10^{-8} \text{ kg/coul}$$

$$\therefore m_{\text{Cu}} = Z_{\text{Cu}} I t,$$

$$\therefore I = \frac{m_{\text{Cu}}}{Z_{\text{Cu}} t} = \frac{0.0001 \text{ kg coul}}{32.94 \times 10^{-8} \text{ kg} \times 600 \text{ S}}$$

$$= \frac{10^{-4} \times 10^8}{32.94 \times 6 \times 10^2} \text{ A}$$

$$= 0.506 \text{ A}$$

\therefore Heat developed in the coil = $I^2 R t$ Joule

$$= (0.506)^2 \text{ A}^2 \times 100 \Omega \times 600 \text{ S}$$

$$= 15362 \text{ J.}$$

Ex. 7.10 A Silver and a Copper voltameter are connected in parallel across a 6V battery of negligible internal resistance. In half an hour 1g of Copper and 2g of silver are deposited. Calculate the rate at which energy is supplied by the battery. Given $Z_{\text{Cu}} = 3294 \times 10^{-7} \text{ g/c}$ and $Z_{\text{Ag}} = 1118 \times 10^{-6} \text{ g/c}$.

Soln.

As the two voltameters are connected in parallel, the current in each is separate. The block circuit diagram is

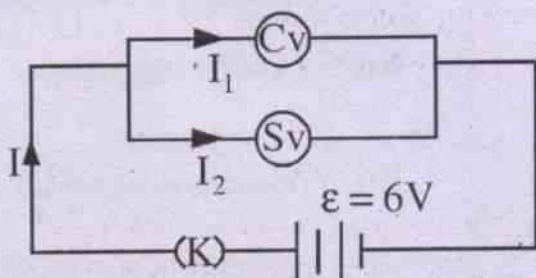

If I_1 and I_2 are the currents in Cu and Ag voltameters respectively, then

$$m_{\text{Cu}} = Z_{\text{Cu}} I_1 t$$

$$m_{\text{Ag}} = Z_{\text{Ag}} I_2 t$$

Here $t = 30 \text{ min} = 1800 \text{ S}$, $m_{\text{Cu}} = 1 \text{ g}$, $m_{\text{Ag}} = 2 \text{ g}$

$$\therefore I_1 = \frac{m_{\text{Cu}}}{Z_{\text{Cu}} t} = \frac{1 \text{ g}}{3294 \times 10^{-7} \frac{\text{g}}{\text{c}} \times 1800 \text{ s}} = 1.687 \frac{\text{c}}{\text{s}}$$

$$= 1.687 \text{ A}$$

$$I_2 = \frac{m_{\text{Ag}}}{Z_{\text{Ag}} t} = \frac{2 \text{ g}}{1118 \times 10^{-6} \frac{\text{g}}{\text{c}} \times 1800 \text{ s}} = 0.9938 \text{ A}$$

$$\therefore I = I_1 + I_2 = 2.681 \text{ A}$$

\therefore Rate at which energy is supplied by the battery = $P = \epsilon I = 6 \text{ V} \times 2.681 \text{ A} = 16.086 \text{ W}$.

Ex. 7.11 In a copper plating experiment difference between final and initial mass of copper cathode is found to be 8.42 g. The ammeter connected in the circuit gives a steady reading of 12.3 A for 35 minutes for which electrolysis is carried out. Calculate the error in the ammeter reading, if any, given that $F = 96485 \text{ c/mol}$, atomic mass of $\text{Cu} = 63.54$.

Soln.

$$\text{Given } m = 8.42 \text{ g}$$

$$t = 35 \times 60 \text{ s} = 2100 \text{ s.}$$

\therefore Atomic mass of $\text{Cu} = 63.54$ and taking its valency to be 2, the chemical equivalent of

$$\text{Cu} = c_{\text{Cu}} = \frac{63.54}{2} = 31.77$$

From the definition of Faraday constant F

31.77 g of Cu can be liberated by 96485 coul of charges

\therefore 8.42 g of Cu can be liberated by

$$\frac{96485 \text{ coul}}{31.77 \text{ g}} \times 8.42 \text{ g} = 25571.41 \text{ coul} = q$$

\therefore The current capable of liberating it = $\frac{q}{t}$

$$= \frac{25571.41 \text{ coul}}{2100 \text{ S}} = 12.18 \text{ A (True current)}$$

Recorded current in the ammeter = 12.3 A

\therefore Error in current reading = 12.3 A - 12.18 A = 0.12 A

Ex. 7.12 It is desired to deposit 0.05 Kg of copper on its cathode in a voltameter. Calculate the time for which a steady current of 20A should be maintained for the purpose if $F = 96485$ coul per mol and atomic mass of Cu = 63.54.

Soln.

Given $m = 0.05$ kg = 50 g

$I = 20$ A

$F = 96485$ coul/mole

c of copper = $\frac{63.54}{2} = 31.77$

$$\therefore Z = \frac{c}{F} = \frac{31.7}{96485 \text{ coul/mol}}$$

Now $m = ZIt$, so that $t = \frac{m}{ZI} = \frac{m}{\frac{c}{F}I} = \frac{Fm}{cI}$

$$\begin{aligned} \Rightarrow t &= \frac{96485 \text{ coul/mol} \times 50 \text{ g}}{31.77 \text{ g/mol} \times 20 \text{ coul/s}} \\ &= \frac{96485 \times 50}{31.77 \times 20} \text{ S} \\ &= 7592.46 \text{ S} \approx 7593 \text{ S} = 2.109 \text{ hr} \\ &= 2 \text{ hr } 6 \text{ min } 54 \text{ S} \end{aligned}$$

SUMMARY

1. Electric energy is the potential energy gained by a charge to move from one point to another in an electric field.

$$W = VIt = I^2Rt = \frac{V^2t}{R}$$

2. Electric power is the time rate of use of electrical energy or electrical work done.

$$P = \frac{W}{t} = VI = I^2R = \frac{V^2}{R}$$

3. Electric energy and power are measured in joule and watt respectively in S.I. system of units.
4. Kilowatt hour is the practical unit of electrical energy in terms of which cost of electricity used is calculated. 1 kilowatt hour = 3.6×10^6 J.
5. Power consumed in a circuit is maximum when $R=r$.
6. Heat developed in a resistor is given by

$$Q = \frac{I^2Rt}{J} \text{ cal}$$

7. Joule's laws of heating

(i) $Q \propto I^2$ (R, t being const.)

(ii) $Q \propto R$ (I, t being const.)

(iii) $Q \propto t$ (I, R being const.)

8. If for a given potential difference across a resistor power P is dissipated in it, then

$P \propto A$ (Area of cross section of the resistor) (ρ and ℓ being const.)

$P \propto \frac{1}{\rho}$ (A and ℓ being const.)

$P \propto \frac{1}{\ell}$ (A and ρ being const.)

9. Electrolysis is the process of separating the +ve and the -ve ions in the chemical reaction brought about by electric current maintained through a conducting solution.
10. +ve terminal of a voltameter is called the anode and the -ve terminal the cathode.
11. Ions liberated at the cathode are cations which are +ve. Ions liberated at the anode are anions which are -ve.

12. Faraday's laws of electrolysis

- (i) mass of ion liberated at an electrode is proportional to the quantity of charge passing through the electrolyte.

$$m \propto q$$

$$\Rightarrow m = Zq = ZIt$$

- (ii) For the same quantity of charge passing through different electrolytes, the masses of different ions liberated are proportional to their respective chemical equivalents.

$$m \propto C$$

$$\frac{m_1}{m_2} = \frac{C_1}{C_2}$$

13. Electro chemical equivalent Z of a substance is the mass of the substance deposited per unit charge passing through the electrolyte.

14. Chemical equivalent of a substance is the ratio of its atomic mass to valency. i.e. $c = m_A / v$ when m_A is atomic mass and v is valency.

15. Ratio of c/Z for any substance is a constant and is called Faraday constant F .

$$F = 9.64867 \times 10^7 \text{ coul/kg.}$$

16. One Faraday is the quantity of charge that liberates gram equivalent of a substance during electrolysis.

$$1F = 96500 \text{ coul}$$

- $1F = N_A e$ where N_A is Avagadro's number and e is electronic charge.

MODEL QUESTIONS

A. Multiple Choice Type Questions :

1. The unit conventionally used to measure electric energy consumed by a consumer is
 - a) 1 Joule
 - b) 1 erg
 - c) 1 calorie
 - d) 1 KWH
2. An electric iron of 750 W power is connected to a 220 V mains. The current drawn by the iron is nearly
 - a) 3.4 A
 - b) 3A
 - c) 0.3 A
 - d) 0.02 A
3. Of the two bulbs used in a house one glows more brightly than the other. Then which of the following statements is true ?
 - a) The brighter bulb has less resistance.
 - b) The brighter bulb has more resistance
 - c) The potential difference across the dimmer bulb is less.
 - d) The potential difference across the brighter bulb is less.
4. The power consumed by a simple circuit having total resistance R is P. If the resistance is reduced by half, the power consumed will be
 - a) P/2
 - b) P
 - c) 2 P
 - d) 4 P
5. Three equal resistors connected in series with a source of emf together dissipate 10 W of power. The power dissipated by these resistors connected in parallel will be
 - a) 10 W
 - b) 30 W
 - c) 90 W
 - d) 100 W
6. A 100 W, 250 V bulb and a 200 W, 250 V bulb are connected in series and the combination is connected across a supply voltage of 230 V. Then
 - a) 100 W bulb glows dimmer.
 - b) 200 W bulb glows dimmer.
 - c) the current through 100 W bulb is more.
 - d) the current through 200 W bulb is more.
7. Two heating wires of equal lengths are first connected in series and then in parallel. If the combinations are separately connected across the same supply line for the same time, the ratio of the heat produced in the first case to that in the second is
 - a) 1:4
 - b) 1:2
 - c) 2:1
 - d) 4:1 (CEE,1990)
8. Under appropriate conditions the maximum power dissipated by an external resistance R, when connected to the cell of emf ϵ and internal resistance r, is
 - a) ϵ^2/r
 - b) $\epsilon^2/2r$
 - c) $\epsilon^2/3r$
 - d) $\epsilon^2/4r$
9. The water in an electric kettle begins to boil 15 minutes after being switched on. To make it boil in 10 minutes by connecting to the same mains the length of the kettle coil should be
 - a) 2/3 of the original length
 - b) 3/2 of the original length
 - c) 4/9 of the original length
 - d) 9/4 of the original length
10. A 40 W tube light is in parallel with a room heater both connected to a stable

- main A.C. supply line. If the light is switched off, the heater output
- will be larger
 - will be smaller
 - will not change
 - will be zero.
- A resistor R_1 dissipates power P when connected to a certain generator. If a resistance R_2 is put in series with R_1 , the power dissipated by R_1 will
 - decrease
 - increase
 - remain the same
 - increase or decrease depending on the values of R_1 and R_2 .
 - In the case of electrolysis of water in a water voltameter, the ratio of the volume of liberated hydrogen to that of oxygen is
 - 1:2
 - 1:1
 - 2:1
 - 4:1
 - The S.I. unit of electrochemical equivalent is given by
 - Kg/A
 - Kg/coul
 - coul/Kg
 - A/Kg
 - In the case of electroplating of iron by nickel
 - iron is used as anode
 - iron is used as cathode
 - nickel used as cathode
 - nickel is used as anode and iron as cathode
 - A copper voltameter and a zinc voltameter are connected in series so that the same quantity of charge can flow through both. The ratio of mass of substance deposited on the cathode of the two is directly proportional to the ratio of their respective
 - densities
 - volume
 - valencies
 - chemical equivalents
 - A steady current of 1 A is maintained through a silver voltameter for 5 hours. If $Z_{Ag} = 111.8 \times 10^{-8}$ kg/coul, the amount of silver liberated during electrolysis will be nearly
 - 0.2 gm
 - 2 gm
 - 20 gm
 - 200 gm
 - The electrochemical equivalent of a material depends on
 - the nature of the material.
 - the current through the electrolyte containing the material.
 - the amount of charge passed through the electrolyte.
 - the amount of the material present in the electrolyte.
 - The dimensions of Faraday constant is
 - $M A^{-1} T^{-1}$
 - $M T A^{-1}$
 - $M A T^{-1}$
 - $M^{-1} AT$
 - The metal which is not extracted by electrolysis is
 - aluminium
 - iron
 - silver
 - gold
 - One Faraday of charge is equal to
 - 9.65×10^7 coulomb
 - 9.65×10^6 coulomb
 - 9.65×10^5 coulomb
 - 9.65×10^4 coulomb
- B. Very Short Answer Type Questions :**
- Name the S.I. units of electric energy and power.

2. How many joules will make one kilowatt hour ?
 3. How many joules will make one calorie ?
 4. Define electrochemical equivalent of a substance.
 5. Define the Faraday constant.
 6. Is Faraday constant a universal constant ?
 7. Is Faraday constant dimensionless ?
 8. Arrange the following energy units in order of increasing magnitude :
Kilowatt hour, foot pound, erg, joule.
 9. State the condition for maximum power consumed by an electric circuit.
 10. Name two important applications of heating effect of current.
 11. Name two important applications of electrolysis.
 12. Mention the dimension of electric power.
 13. What is the percentage of decrease in power if current flowing through a resistor drops by one percent.
 14. How much of charge in coulomb is present in one Cu^{++} ion ?
 15. Mention the relationship between chemical equivalent and electrochemical equivalent of a substance.
 16. Name the liquid that does not undergo electrolysis even if it is a very good conductor of electricity.
 17. A 25 W and 100W bulbs are connected in parallel. Which bulb flows brightly ?
[CBSE Sample Paper]
 18. A 25 watt bulb and a 100 watt bulb are joined in series and connected to mains which bulb will glow brighter ?
[CBSE Sample Paper]
- C. Short Answer Type Questions :**
1. State Joule's laws of heating.
(CHSE, 1995)
 2. State Faraday's laws of electrolysis.
 3. Which will have more resistance, a lamp of 60 W or a lamp of 100 W ? Why ?
 4. Mention the physical significance of Faraday constant.
 5. Show that the maximum power furnished by a cell to a resistor $R = \frac{\epsilon^2}{4R}$ where ϵ stands for the emf of the cell.
 6. Find the resistance of a 25 W, 250 V bulb.
 7. How does a voltmeter differ from a voltmeter ?
 8. Can alternating current (a.c) be used in electrolysis ? Explain your answer.
 9. Distinguish between chemical equivalent and electrochemical equivalent of a substance.
 10. Calculate the cost of electricity if a 1 KW heater is used for 10 days at the rate of 1 hour per day. Assume the cost of energy to be Re 1.00 per unit.
 11. A d.c. motor taking 5A on 220 V line is 80% efficient. Find its power.
 12. Mention why a fuse is used in house wiring.
 13. Two bulbs each of 100 W are connected in parallel. Find the power consumed by the combination. [CHSE, 1997]
 14. A 12 V battery is charged at the rate of 5A for 25 hours. Calculate the energy put into the battery in KWH.
 15. Calculate the mass of copper liberated in a copper voltmeter by the passage of 1A d.c. for 1 hour. $Z_{\text{Cu}} = 6.6 \times 10^{-7} \text{ Kg/C}$.
 16. As temperature increases, the viscosity of liquids decreases considerably. Will it decrease the resistance of an electrolyte ? Explain your answer.
 17. Do the electrodes in an electrolytic cell have fixed polarity like a battery ?
 18. If two electric lamps each of 100W, 220V are connected in series to a power supply of 220V, find the power consumed.
[CHSE 1993 A]

19. One ampere of current flowing through a wire produces 60 cal of heat in 15S. What is the resistance of the wire ?

[CHSE 1992 A]

20. What is the nature of filament inside a zero watt lamp ? (CHSE 1991 S)

21. An electric iron has the marking 880 W and 220 V. Calculate the resistance of the coil inside iron. [CHSE 1991 A]

22. A heater coil is cut into two parts and only one of them is used in the heater. What is the ratio of the heat produced by this half coil to that by the original coil ?

[CBSE Sample Paper]

23. Two heater coils made of same material are connected in parallel across the mains. The length and diameter of the wire of one of coils are double that of the other. Which one of them will produce more heat ? [CBSE Sample Paper]

D. Long Answer Type Questions :

- Obtain an expression for the heat developed in a resistor carrying current. Hence mention Joule's laws of heating. Find the amount of heat generated by a 1 KW, 250 V heater when used for 1 hour by connecting it to a 250 V mains.
- State Joule's laws in connection with heating effect of electric current. Describe how will you verify them experimentally.
- State and explain Faraday's laws of electrolysis. Calculate the value of current required to deposit 0.972 g of chromium in 3 hours. E.C.E of chromium = 0.00018 g / coul.
- State and explain Faraday's laws of electrolysis. Show from the second law that $Z \propto c$ for an element where Z is the electrochemical equivalent of the element and c its chemical equivalent.

Calculate the e.c.e of silver given that e.c.e of copper = 3.293×10^{-7} kg/coul.

c.e. of silver = 107.87

c.e of copper = 31.77 [CHSE 1996 S]

5. Define Faraday constant. How is it related to electronic charge ? Explain the significance of Faraday number and show how it leads to atomicity in electricity.

E. Numerical Problems :

- Calculate the time needed for 1 KW. heater to warm 1 litre of water from 30°C to 90°C.
- A steady current of 10A maintained for 1 hour in an electrolyte deposits 12.2 g of zinc. Find the equivalent mass of Zinc in Kg.
- An electric kettle has two coils. When one of them is switched on, water in the kettle boils in 20 minutes. When the other coil is switched on, water boils in 10 minutes. Calculate the time taken for the water to boil if both the coils are connected in parallel.
- Calculate the energy stored in a 12 V, 50 AH battery if its internal resistance is negligible.
- Find the time required to electroplate 4g of silver on a brass plate by the use of a steady current of 1A. E.C.E of silver is 1.118×10^{-6} kg/coul.
- A 25 W, 120 V light bulb and a 100 W, 120 V bulb are connected in series across a 240 V line. Assuming that the resistance of each bulb does not vary with temperature, calculate the power dissipated in each bulb.
- Calculate the cost of electricity at the rate of Rs. 2.50 per unit if a 60 W and a 100W lamp burn for 15 days at the rate of 3 hours each day.

8. A house is fitted with 20 lamps of 60 W each, 10 fans consuming 0.5 A each and an electric kettle of resistance 110Ω . If energy is supplied at 220 V and costs Rs. 2.50 per unit, calculate the average monthly bill for running each appliance for 6 hrs a day on the average.
9. A spoon is to be silver plated by a steady current of 0.1A. The thickness of silver coating should be 0.0001 cm over a surface of 20 cm^2 . Calculate the period of electrolysis if $\rho_{\text{Ag}} = 10.5 \text{ g/cm}^3$ and $Z_{\text{Ag}} = 1.118 \times 10^{-6} \text{ kg/coul}$.
10. A copper and a silver voltameter are connected in series. How much silver will be deposited in the silver voltameter when 0.5 g of copper is deposited in the copper voltameter. Chemical equivalents of copper and silver are 32 and 108 respectively.
11. A piece of metal weighing 200 g is to be electroplated with 5% of its weight in gold. If a steady current of 2 A is maintained in the circuit, how long will it take to deposit the required amount of gold? $Z_{\text{Au}} = 0.00068 \text{ g/coul}$.
12. A copper and a water voltameter are connected in series. Calculate the volume of oxygen liberated in the latter when 0.5g of copper is deposited in the former. chemical equivalents of copper and oxygen are 32 and 8 respectively.
13. Determine for how long 1 A of current be maintained through a dilute solution of H_2SO_4 to liberate 1 g of oxygen. How much hydrogen is produced at the same time?
14. A copper voltameter is connected in series with a coil of resistance 100Ω . A steady current is passed through the circuit for 10 minutes and it deposits 0.1g of copper. Calculate the amount of heat produced by the resistor. E.C.E. of copper = $3.3 \times 10^{-7} \text{ kg/coul}$.
15. A silver and a copper voltameter are connected in parallel across a 6V battery of negligible internal resistance. In half an hour, 1g of copper and 2 g of silver are deposited. Calculate the rate at which energy is supplied by the battery. E.C.E. of Cu = $3.294 \times 10^{-7} \text{ kg/coul}$ and E.C.E. of Ag = $1.118 \times 10^{-6} \text{ kg/coul}$.
16. Two heaters are marked 200 V, 300 W and 200 V, 600 W. If the heaters are connected in series and the combination connected to a 200 V dc supply, which heater will produce more heat?

[CBSE Sample Paper]

F. True - False - Type Questions

- Two heating coils one of fine wire and the other of thick wire made of same material and of same length are connected in series and then in parallel. Then in series the fine wire liberates more energy, while in parallel the thick wire liberates more energy.
- An ordinary 100W bulb has more resistance than a 60W lamp.
- The kolo Watt-hr is a unit of energy.
- The heat energy produced in a current carrying wire is directly proportional to the square of the current.
- At a constant voltage, the heat developed in a uniform wire varies inversely as the length of the wire used.
- The unit conventionally used to measure electric energy consumed by a consumer is 1 KWH.
- One 1 KWH is equal to $3.6 \times 10^6 \text{ J}$.
- Maximum power dissipated by an external resistance R, when connected to the cell of emf ε , and internal resistance r is $\varepsilon^2/4r$.

G. Fill - in - Blank Type Questions

1. When current is divided between two resistances according to Kirchoff's law, then heat produced is.....
2. Among the bulbs of different wattages joined in parallel, the bulb of wattage glows maximum, but in series the bulb of wattage glows maximum.
3. Kilo Watt hr = $\frac{\text{.....} \times \text{amper} \times \text{.....}}{\text{.....} \times \text{.....}}$

$$= \frac{(\text{Volt})^2 \times \text{.....}}{\text{.....} \times \text{.....} \times \text{.....}}$$
4. A constant voltage is applied between the ends of a uniform metallic wire. The heat developed is doubled of both the length and radius of the wire are.....

5. 10 bulbs of 50 Watt, each glow 10 hrs every day for 30 days. The electric energy (in KWH) consumed will be

H. Correct the following sentences :

1. $1 \text{ KWH} = 3 \times 10^5 \text{ J}$
2. An ordinary 40W bulb has more resistance than 25W bulb.
3. When heat Q is measured in calories and $J = 4.19 \text{ Joules/calorie}$, we have $Q = J I^2 R t$.
4. 5 Joules make a calorie.
5. The value of Faraday constant is approximately $9.65 \times 10^8 \text{ coul./kg}$.
6. Faraday constant is dimensionless.
7. The S.I unit of electro chemical equivalent Z is kg/ab-coul.

ANSWERS

A. Multiple Choice Type Questions :

1. (d) 2. (a) 3. (a) 4. (c) 5. (c) 6. (b) 7. (d) 8. (d)
 9. (a) 10. (c) 11. (a) 12. (c) 13. (b) 14. (d) 15. (d) 16. (c)
 17. (a) 18. (d) 19. (b) 20. (d)

E. Numerical Problems :

1. 4 min 12 sec
 2. 32.7 g
 3. 6 min 40 sec
 4. 2.16×10^4 J
 5. 59 min 36 sec or 1 hr nearly
 6. $P_1 = 64$ W and $P_2 = 16$ W

However the 1st one i.e. 25W bulb glows brilliantly for a moment and gets fused in a short time and the circuit is disconnected.

7. Rs. 18.00
 8. Rs. 1233.00
 9. 3 min 8 sec
 10. 1.688 g
 11. 2 hr 3 min 55 sec
 12. 350 cc
 13. 3 hr 21 min 2 sec, 0.125 g
 14. 3643 cal
 15. 16 J/S
 16. Heat produced in 300 W heater is more than that produced in 600 W heater.

- F. (1) True (2) False $\left(R = \frac{V^2}{P}\right)$ (3) True (4) True (5) True, because $P = \frac{V^2}{R} = \frac{V^2 A}{\rho}$ (6) True
 (7) True (8) True

- G. (1) minimum (2) higher, lower (3) $\frac{\text{Volt} \times \text{ampere} \times \text{sec}}{1000 \times 3600} = \frac{\text{Volt}^2 \times \text{sec}}{1000 \times \text{ohm} \times 3600}$ (4) doubled,

$$P = \frac{V^2}{R} = \frac{V^2 A}{\rho'} = \frac{V^2 \pi r^2}{\rho'} \quad (5) \text{ 15 KWH.}$$

8

Magnetic Effect of Electric Current

8.1 Introduction

We have seen that electric fields are created by electric charges and magnetic fields by magnetic dipoles. The study of these two fields gave rise to the development of electricity and magnetism as two separate branches of physics. No link between the two was known almost till the beginning of nineteenth century. There was an important breakthrough in the year 1820 when Hans Christian Oersted, a Danish physicist observed that a magnetic compass needle kept parallel to and below a current carrying wire was deflected from its normal north-south orientation as shown in Fig. 8.1c. There was no deflection when no current existed in the wire vide Fig. 8.1b. The deflection was in opposite direction when the needle was placed above the wire. Oersted's experimental arrangement is shown in Fig. 8.1. It clearly indicates the presence of a

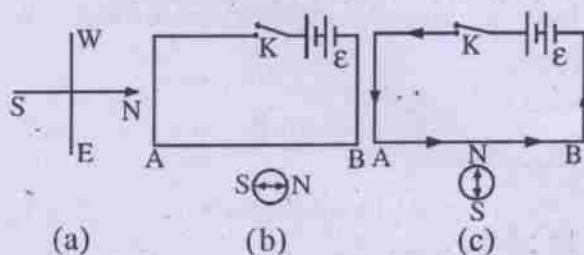

Fig. 8.1

different magnetic field other than the earth's field. Oersted attributed it to the electric current in the wire. Later experiments by others indicated that the magnetic field due to current

existed in planes perpendicular to the conductor and the lines of induction in the field could be traced. Such lines of induction due to a straight current carrying conductor are concentric circles as shown in Fig. 8.2.

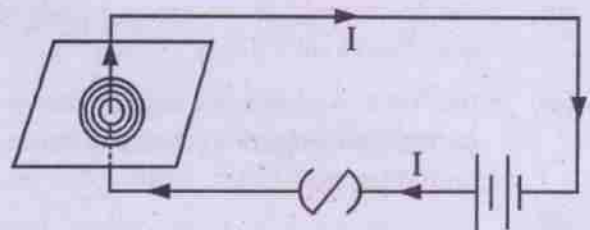

Fig. 8.2

Almost in the same year 1820, Andrae Marie Ampere observed separately that two parallel current carrying conductors placed side by side, attracted each other. He attributed the phenomenon to the interaction existing between the magnetic fields produced by the two currents. From his observations and analysis he said that electric currents could be the source of all magnetism. It could be demonstrated that a freely suspended current carrying wire within the two poles of a strong horse shoe magnet got deflected from its normal position (Fig. 8.3). All these findings established an intimate relationship between electric current and magnetism. Hence a new subject called electromagnetism began to grow. It was subsequently enriched by the contributions of the then researchers like J.B. Biot, F. Savart, Michale Faraday, Joseph Henry, James Clarke

Maxwell and many others. It became the leading topic of nineteenth century physics.

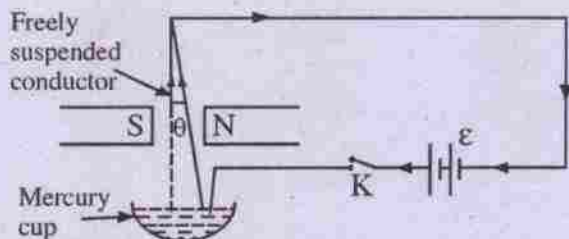

Fig. 8.3

In the present chapter we shall make a simple beginning of the phenomenon and our discussions will be confined to the followings i.e.

- (i) the static magnetic field produced by steady current,
- (ii) the force exerted on moving charged particles in such fields;
- (iii) the forces and torques experienced by current carrying conductors and current circuits in such fields, and
- (iv) the application of the phenomenon to the making and working of some electrical equipments like galvanometer, ammeter and voltmeter.

8.2 The magnetic field and magnetic induction

Earlier we have studied magnetic field as a limited region of space surrounding a magnet. The poles of another magnet brought into this field experience forces. This is called interaction between the field and the magnet. A magnetic field is identified by a vector called magnetic induction \vec{B} at any point. It is defined as the magnetic force per unit pole strength when a small north pole is assumed to be placed at that point. However, it is difficult to measure \vec{B} at any point practically from this definition as a single isolated pole in magnetism cannot be obtained. This difficulty is removed if any magnetic phenomenon is looked upon to have

some electrical origin. Accordingly the magnetic field vector \vec{B} at any point in the field has been defined from the knowledge of the force experienced by a moving charge in a magnetic field. Let us call it the magnetic force \vec{F}_m . A charge does not experience any such force if it is at rest. Experimentally one may observe the following points about magnetic force.

- (i) At any point in the magnetic field there is one fixed direction along which if a charged particle (+ve) moves, it experiences no force. This direction is taken as the direction of \vec{B} at that point.
- (ii) If the velocity \vec{v} of the charged particle makes angle θ with the direction of \vec{B} at any point, the magnitude of magnetic force at that point is proportional to $v \sin \theta$.
- (iii) The magnitude of magnetic force is proportional to the magnitude of the moving charge q .
- (iv) The direction of magnetic force on a moving negative charge is opposite to that on a moving +ve charge.
- (v) The direction of magnetic force is always perpendicular to the direction of \vec{B} and \vec{v} at any point.

Taking all these facts into account the magnetic force \vec{F}_m on a moving charge is written in the form.

$$\vec{F}_m = q (\vec{v} \times \vec{B}) \quad \dots 8.2.1$$

$$\text{Then } |\vec{F}_m| = q |\vec{v}| |\vec{B}| \sin \theta \quad \dots 8.2.2$$

$$\text{and } |\vec{B}| = \frac{|\vec{F}_m|}{q v \sin \theta} \quad \dots 8.2.3$$

One can thus obtain \vec{B} by measuring \vec{F}_m on a

given charge which moves with a known speed \vec{v} in a known direction. The direction of \vec{B} is uniquely defined by applying the rules of vector product. To be more elaborate, if \vec{v} and \vec{B} of eq. 8.2.1 are contained in XY plane as shown in Fig. 8.4, then the direction of \vec{F}_m is along the Z direction by cross product rule.

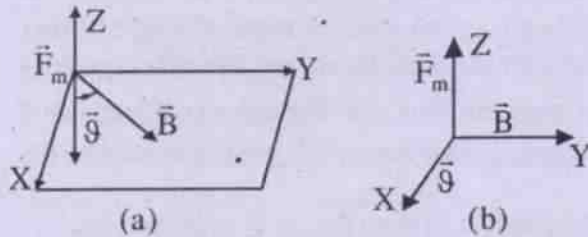

Fig. 8.4

In a special case if \vec{v} is along X-axis, and \vec{B} along Y-axis then \vec{F}_m is along Z axis as in Fig. 8.4b. As $\vec{v} = \hat{i}v$ and $\vec{B} = \hat{j}B$,

$$\begin{aligned}\vec{F}_m &= q\vec{v} \times \vec{B} = q(\hat{i}v \times \hat{j}B) \\ &= (\hat{i} \times \hat{j}) q v B = \hat{k} q v B\end{aligned}$$

To easily remember the direction of \vec{F}_m one may follow the **RIGHT HAND THUMB RULE** which states that "If the other fingers except the thumb of right hand are curled around the thumb from the direction of \vec{v} to that of \vec{B} , then the thumb points in the direction of magnetic force \vec{F}_m . This is shown in Fig. 8.5 i.e.

(a) The right hand rule (in which \vec{v} is swept into \vec{B} through the smaller angle ϕ between them) gives the direction of $\vec{v} \times \vec{B}$ as the direction of the thumb. (b) If q is positive, then the direction of $\vec{F}_m = q\vec{v} \times \vec{B}$ is in the direction of $\vec{v} \times \vec{B}$. (c) If q is negative, then the direction of \vec{F}_m is opposite that of $\vec{v} \times \vec{B}$.

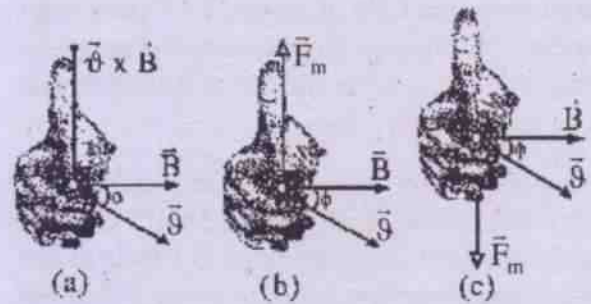

Fig. 8.5

If the plane containing \vec{v} and \vec{B} is taken as the plane of the paper then the magnetic force vector \vec{F}_m will be perpendicular to this plane and will be directed either into the plane of the paper or away from it depending on the orientations of \vec{v} and \vec{B} . When directed into the plane of the paper it is denoted by the symbol \odot and when directed out of the plane of the paper it is denoted by the symbol \otimes .

Unit of \vec{B}

The S.I. unit of \vec{B} is obtained from eq. 8.2.3 and is called a Tesla (T). It is equal to newton per ampere-meter. i.e.

$$\begin{aligned}1 \text{ Tesla} &= \frac{1 \text{ newton}}{1 \text{ coulomb} \times 1 \frac{\text{metre}}{\text{sec}}} \\ &= \frac{1 \text{ n}}{\text{coul} \cdot \text{m}} = \frac{\text{n}}{\text{A} \cdot \text{m}}\end{aligned}$$

There is another C.G.S. electromagnetic unit of \vec{B} called Gauss.

$$1 \text{ Gauss} = \frac{1 \text{ dyne}}{1 \text{ ab amp} \cdot 1 \text{ cm}} = 10^{-4} \text{ Tesla}$$

The dimension of \vec{B} is obtained as $M^1 T^{-2} A^{-1}$.

A Tesla is quite a large unit of magnetic field. The magnetic field at the earth's surface is

around 50×10^{-6} tesla, However, in laboratory large magnetic field of around 10 T have been produced using large superconducting magnets. Magnetic field on the surface of a neutron star is as high as 10^8 T.

Ex. 8.1.1 An alpha particle is projected vertically upward with a speed 3×10^4 km/s. in a region where magnetic field of 1 tesla exists in the direction from south to north. Calculate the magnetic force on the α - particle.

Soln.

Charge q of the α - particle = $+2e$

velocity $\vec{v} = \hat{k} 3 \times 10^7$ m/s

(the vertical direction is taken as the direction of Z axis for convenience)

Field $\vec{B} = 1 \hat{j}$ tesla

(the direction from south to north is taken as the direction of Y-axis)

$$\therefore \vec{F}_m = q(\vec{v} \times \vec{B})$$

$$= 2e(\hat{k} 3 \times 10^7 \text{ m/s} \times \hat{j} \text{ tesla})$$

$$= 2 \times 1.6 \times 10^{-19} \times 3 \times 10^7$$

$$\frac{\text{m}}{\text{s}} \times \frac{1 \text{ n}}{\text{A} \cdot \text{m}} \times (\hat{k} \times \hat{j})$$

$$= 9.6 \times 10^{-12} (-\hat{i}) \text{ n}$$

Thus the force experienced is 9.6×10^{-12} n directed from East to West as shown as.

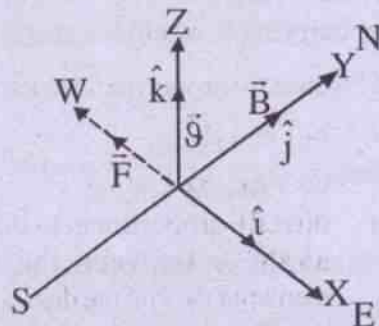

8.3 Magnetic flux

A region of magnetic field is assumed to be filled with magnetic lines of induction. The tangent drawn to such curves at any point gives the direction of \vec{B} at that point. The number density of these lines per unit area held perpendicular to these lines gives a quantitative measure of the field vector \vec{B} relative to a known field. The number of lines of induction through certain area is termed as magnetic flux through the area. However, the exact quantity of magnetic flux $\Delta\phi$ through a small area ΔA around a point is mathematically known by the dot product of the vectors \vec{B} and $\vec{\Delta A}$, i.e.

$$\Delta\phi = \vec{B} \cdot \vec{\Delta A} \quad \dots 8.3.1$$

$$\Rightarrow \Delta\phi = B\Delta A \cos\theta \quad \dots 8.3.2$$

In eq. 8.3.2 the $\Delta A \cos\theta$ is the projection of area ΔA and is perpendicular to direction of \vec{B} , as shown in fig 8.6. It is to be noted here that area is treated as a vector and the outward drawn normal to the area at a point becomes the direction of the area at that point. Taking area $\vec{\Delta A}$ to be infinitesimally small eq. 8.3.2 may be written as

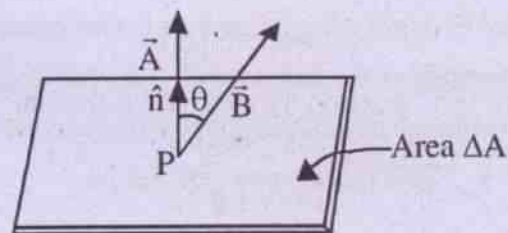

Fig. 8.6 (Area shown as a vector)

$$d\phi = \vec{B} \cdot d\vec{A} = \vec{B} \cdot \hat{n} dA$$

where \hat{n} is unit vector in the direction of normal to dA . Then total flux through area A of the surface is obtained as

$$\phi = \int_0^{\phi} d\phi = \int_A \vec{B} \cdot \hat{n} dA \quad \dots 8.3.3$$

In a special case when \vec{B} is uniform over a region and is perpendicular to the area A at every point

$$\phi = BA \cos 0^\circ = BA \quad \dots 8.3.4$$

$$\text{Then } B = \frac{\phi}{A} \quad \dots 8.3.5$$

Thus B is termed as the magnetic flux density which means magnetic flux per unit area which is held perpendicular to the direction of \vec{B} .

It is to be noted carefully that the magnetic flux through a closed surface is zero.

The unit and dimension of magnetic flux ϕ

The unit of magnetic flux in S.I. system is called Weber (Wb). Using eq. 2.4.6 we can find that

$$\begin{aligned} 1 \text{ weber} &= 1 \text{ Tesla} \times 1 (\text{metre})^2 \\ &= \frac{1 \text{ newton}}{\text{Amp. metre}} \times 1 (\text{metre})^2 \\ &= \frac{\text{newton metre}}{\text{Ampere}} \text{ i.e. } \frac{\text{N m}}{\text{A}} \\ &= \text{Joule/Ampere.} \end{aligned}$$

In C.G.S. electromagnetic units, the unit of magnetic flux is called maxwell.

$$\begin{aligned} 1 \text{ maxwell} &= 1 \text{ Gauss} \times 1 (\text{cm})^2 \\ &= \frac{\text{dyne.cm}}{\text{Ab.amp.}} = 10^{-8} \frac{\text{N.m}}{\text{A}} = 10^{-8} \text{ Tesla} \end{aligned}$$

The dimension of ϕ , from eq. 8.3.4 may be obtained as $M^1 T^{-2} A^{-1} \cdot L^2 = M L^2 T^{-2} A^{-1}$.

Ex. 8.3.1 A rectangular area of 10 cm x 6 cm is held in a uniform magnetic field of 10^{-4} T such

that the field makes angle 30° with the plane of the area. Calculate the magnetic flux through the area.

Soln.

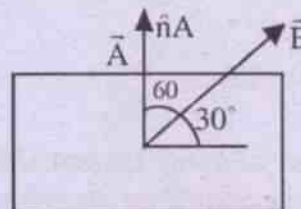

Given that

$$\text{Area } A = 0.1 \text{ m} \times 0.06 \text{ m} = 0.006 \text{ m}^2$$

$$B = 10^{-4} \text{ Tesla.}$$

The plane of the area makes angle 30° with \vec{B} .

\therefore The area vector \vec{A} makes angle 60° with \vec{B} .

$$\therefore \phi = BA \cos \theta = 10^{-4} \text{ T} \times 6 \times 10^{-3} \text{ m}^2 \cos 60^\circ = 3 \times 10^{-7} \text{ weber.}$$

8.4 Biot - Savart Law

Following Oersted's discovery of magnetic field produced by a current in 1820, attempts were made to measure this field quantitatively. Two french physicists Baptiste Biot and Felix Savart first of all formulated a law purely from experimental observations and this is known as the famous Biot-Savart Law in electro magnetism. It is the magnetic equivalent of coulomb's law in electrostatics.

The law states that the magnitude of magnetic field ΔB produced at a field point P (Fig. 8.7) due to a small length $\Delta \ell$ of straight conductor carrying current I is

- (i) directly proportional to the product of I and $\Delta \ell$,
i.e. $\Delta B \propto I \Delta \ell$
- (ii) directly proportional to the sine of angle θ between the current element $I \Delta \ell$ and the distance r from the element to the point,

i.e. $\Delta B \propto \sin\theta$

- (iii) inversely proportional to the square of the distance r between the element and the point.

i.e. $\Delta B \propto \frac{1}{r^2}$

The conductor carrying current I , the length element and the point P are shown in Fig. 8.7.

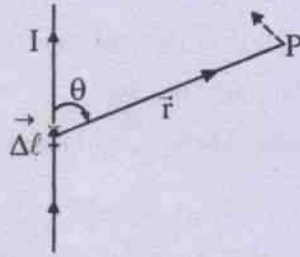

Fig. 8.7 (Magnetic field due to a straight current element)

Mathematically we may write

$$\Delta B \propto \frac{I \Delta \ell \sin\theta}{r^2}$$

$$\Rightarrow \Delta B = \frac{K I \Delta \ell \sin\theta}{r^2} \quad \dots 8.4.1$$

where K is the constant of proportionality depending on the nature of the medium between the element and the point and also on the system of units used.

It is related to magnetic property of the medium called its permeability μ . For vacuum, free space or air this permeability is denoted as

$$\mu_0 \text{ and } K = \frac{\mu_0}{4\pi} = 10^{-7} \text{ Weber/amp.m.}$$

As ΔB is a vector, it is written in vector notation as

$$\vec{\Delta B} = \frac{\mu_0 I \Delta \ell \sin\theta \hat{n}}{4\pi r^2} \quad \dots 8.4.2$$

Where \hat{n} is a unit vector perpendicular to the plane of $\vec{\Delta \ell}$ and \vec{r} and the exact direction is determined by **right hand screw rule**, which states that

"If a screw held in right hand is rotated in the plane of $\vec{\Delta \ell}$ and \vec{r} from $\vec{\Delta \ell}$ to \vec{r} , the direction in which the screw moves gives the direction \hat{n} or $\vec{\Delta B}$."

Eq. 8.4.2 may be written as

$$\vec{\Delta B} = \frac{\mu_0 I \vec{\Delta \ell} \times \vec{r}}{4\pi r^3}$$

using the knowledge of vector product.

To find the total magnetic induction \vec{B} at P the whole length of the conductor is divided into a large number of small elements and the $\vec{\Delta B}_i$'s obtained for each element are added vectorially to find \vec{B} . This is shown in Fig. 8.8.

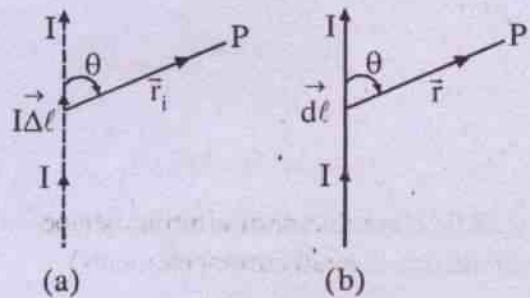

Fig. 8.8

$$\text{Then } \vec{B} = \sum \vec{\Delta B}_i = \sum_i \left(\frac{\mu_0 I \vec{\Delta \ell}_i \times \vec{r}_i}{4\pi r_i^3} \right) \quad \dots 8.4.4$$

If the number i is so large that $\Delta \ell_i$ is infinitesimal, then

$$\vec{B} = \int d\vec{B} = \int \left(\frac{\mu_0 I}{4\pi} \frac{d\vec{\ell} \times \vec{r}}{r^3} \right) \quad \dots 8.4.5$$

The relations 8.4.1 and 8.4.4 obtained by Biot and savart for a straight current carrying conductor were also obtained empirically by Laplace in a later period using a conductor of arbitrary shape as shown in Fig. 8.9. Hence eq. 8.4.1 is also known as **Laplace's equation**.

However, validity of eq. 8.4.1 for small current only cannot be checked by direct experiment for we cannot isolate the effect of one current element from the rest of the circuit. But eq. 8.4.4 or 8.4.5 can be used to find expression for \vec{B} for various current arrangements. The fact that calculated results are consistent with experimental measurements is a general validity of eq. 8.4.1.

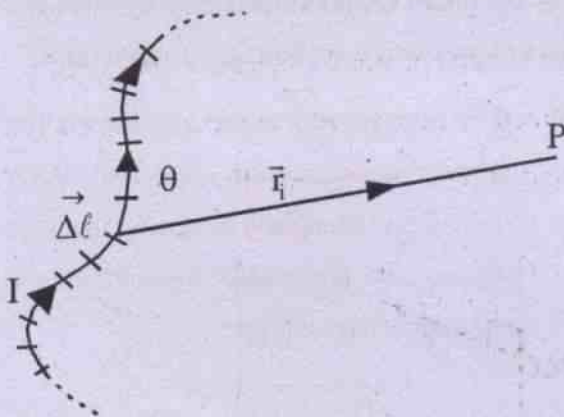

Fig. 8.9 (A conductor of arbitrary shape divided into small current elements)

8.5 Magnetic field due to a straight current

As an application of Biot Savart law let us first of all calculate the magnetic field \vec{B} due to a straight conductor MN of finite length L . Let the steady current in it be I . We shall compute the magnetic field \vec{B} at a point P which is located at a distance $OP = d$ from the conductor. OP is perpendicular distance from P to the conductor.

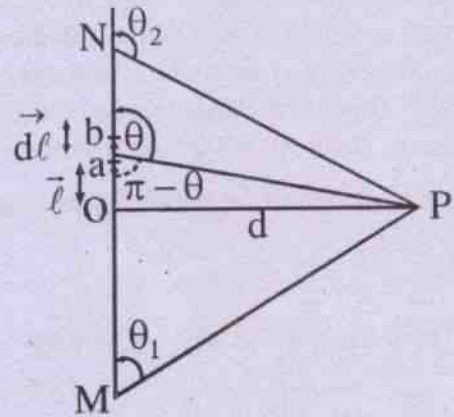

Fig. 8.10 (B due to straight current)

Let us take O as the origin of a cartesian co-ordinate system and the directions \vec{OP} and \vec{ON} (shown in Fig. 8.10) as the directions X and Y axes respectively.

Let ab be a small element of length $d\ell$ of the conductor at a distance ℓ from O . \vec{r} is the vector drawn from $d\ell$ to P and θ is the angle made by $d\ell$ with \vec{r} as shown in the figure.

We have $\vec{r} = \hat{i}d + \hat{j}\ell$

and $d\vec{\ell} = \hat{j}d\ell$

Then $d\vec{B}$ at P due to current element $I d\vec{\ell}$ is written as

$$\begin{aligned} d\vec{B} &= \frac{\mu_0}{4\pi} I \frac{d\vec{\ell} \times \vec{r}}{r^3} \\ &= \frac{\mu_0 I}{4\pi} \frac{\hat{j} d\ell \times (\hat{i}d + \hat{j}\ell)}{r^3} \\ \Rightarrow d\vec{B} &= \frac{\mu_0 I}{4\pi} \frac{(-\hat{k} d\ell d)}{r^3} \quad \dots 8.5.1 \end{aligned}$$

It is thus seen that the direction of \vec{dB} is along the negative direction of Z axis. It is directed into the plane of the paper which is taken as the XY plane. Since the conductor is straight all elements of it lie in XY plane and therefore direction of \vec{B} due to the conductor is directed along $-\hat{k}$.

The magnitude of \vec{dB} is given by

$$\begin{aligned} dB &= \frac{\mu_0}{4\pi} \frac{I r d\ell \sin \theta}{r^3} \\ &= \frac{\mu_0}{4\pi} \frac{I d\ell \sin \theta}{r^2} \quad \dots 8.5.2 \end{aligned}$$

Let us here consider the right angled triangle ObP in which

$$\angle ObP = \pi - \theta. \text{ Then}$$

$$r = d \operatorname{cosec}(\pi - \theta) = d \operatorname{cosec} \theta$$

$$\text{and } \ell = d \cot(\pi - \theta) = -d \cot \theta$$

$$\therefore d\ell = d \operatorname{cosec}^2 \theta d\theta$$

Substituting for r and $d\ell$ in eq. 8.5.2 we have

$$\begin{aligned} dB &= \frac{\mu_0 I}{4\pi} \frac{d \operatorname{cosec}^2 \theta \cdot \sin \theta d\theta}{d^2 \operatorname{cosec}^2 \theta} \\ \Rightarrow dB &= \frac{\mu_0 I}{4\pi} \frac{\sin \theta d\theta}{d} \\ \therefore B &= \frac{\mu_0 I}{4\pi d} \int_{\theta_1}^{\theta_2} \sin \theta d\theta \\ \Rightarrow B &= \frac{\mu_0 I}{4\pi d} [\cos \theta_1 - \cos \theta_2] \quad \dots 8.5.3 \end{aligned}$$

Here in eq. 8.5.3 θ_1 and θ_2 are angles made by the radius vectors drawn from the lowest and the highest elements of the conductor to P

respectively. Taking direction of \vec{B} into account,

$$\vec{B} = (-\hat{k}) \frac{\mu_0 I}{4\pi d} [\cos \theta_1 - \cos \theta_2] \quad \dots 8.5.3$$

Special cases

(i) If the conductor is considered to be infinitely long

then $\theta_1 \rightarrow 0$ and $\theta_2 \rightarrow \pi$, so that

$$\begin{aligned} \vec{B} &= -\hat{k} \frac{\mu_0 I}{4\pi d} [\cos 0 - \cos \pi] \\ &= -\hat{k} \frac{\mu_0 I}{4\pi d} [1 - (-1)] = -\hat{k} \frac{2\mu_0 I}{4\pi d} \\ \Rightarrow \vec{B} &= -\hat{k} \frac{\mu_0 I}{2\pi d} \quad \dots 8.5.5 \end{aligned}$$

It is thus seen that $B \propto I$ and $B \propto \frac{1}{d}$ and this was the result found empirically by Biot and Savart from their experimental observations.

(ii) If P is assumed to be a point on the perpendicular bisector of the conductor of length L, then each distance r from the highest and the lowest elements of the conductor is given by

$$r = \sqrt{\frac{L^2}{4} + d^2}$$

$$\text{and } \cos \theta_1 = \frac{L/2}{\sqrt{d^2 + L^2/4}}$$

$$\cos \theta_2 = \frac{-L/2}{\sqrt{d^2 + L^2/4}}$$

so that $\cos \theta_1 - \cos \theta_2$

$$= \frac{(L/2)(1+1)}{\sqrt{d^2 + L^2/4}} = \frac{L}{\sqrt{d^2 + L^2/4}}$$

$$\therefore \vec{B} = -\hat{k} \frac{\mu_0 I L}{4\pi d \sqrt{d^2 + L^2/4}} \quad \dots 8.5.6$$

Alternative way to find the direction of \vec{B}

The direction of \vec{B} at P can also be found by **right hand thumb rule** which is as follows.

"If the thumb of the right hand is taken along the direction of current along the conductor and the other fingers are curled to pass through P, then the direction of the fingers at P gives the direction of \vec{B} ."

This is shown in Fig. 8.11

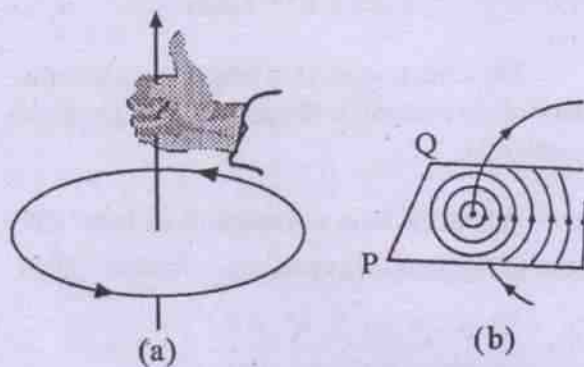

Right hand thumb rule (Lines of induction due to a current)

Fig. 8.11

The lines of induction due to such a current carrying straight conductor are concentric circles in a plane perpendicular to the conductor with the centre on the conductor. This has already been shown in Fig. 8.2.

Ex. 8.5.1 A current of 2A is maintained in a long straight conductor placed in air. Calculate the magnitude of magnetic field at a distance 10cm from the conductor.

Soln.

Given $d = 10 \text{ cm} = 0.1 \text{ m}$

$I = 2 \text{ A}$

$$\therefore B = \frac{\mu_0 I}{2\pi d} = \frac{\mu_0}{4\pi} \frac{2I}{d}$$

$$= 10^{-7} \frac{\text{Wb}}{\text{A.m}} \times \frac{2 \times 2 \text{ A}}{0.1 \text{ m}}$$

$$= 4 \times 10^{-6} \frac{\text{Wb}}{\text{m}^2} = 4 \times 10^{-6} \text{ Tesla}$$

8.6(a) Magnetic field at the centre of a circular coil carrying current.

Shown in Fig. 8.12 is a circular current loop of radius a . We shall calculate the magnetic field \vec{B} due to the loop at its centre when it carries a current I .

For convenience of calculation we assume the loop to be in the XY plane of a cartesian coordinate system having origin at the centre O of a loop. The loop is connected to the current source through two closely spaced parallel leads AB and CD as shown in the diagram.

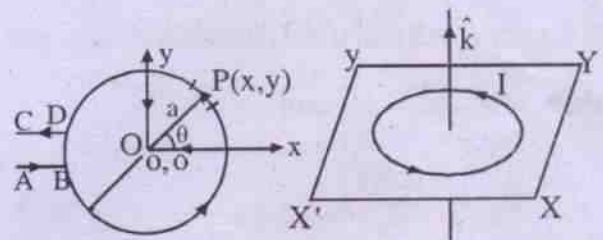

Fig. 8.12

Fig. 8.13

Let us choose a current element $I \vec{dl}$ at $P(x,y)$ located on the loop. From the diagram

$$I \vec{dl} = I (dx \hat{i} + dy \hat{j}) \quad \dots 8.6.1(a)$$

$x = a \cos \theta, y = a \sin \theta, dx = -a \sin \theta d\theta, dy = a \cos \theta d\theta$. The radius vector drawn from this element to the centre is \vec{a} where

$$\vec{a} = x \hat{i} + y \hat{j} \quad \dots 8.6.1(b)$$

Hence the magnetic field $d\vec{B}$ at O due to the element is given by

$$d\vec{B} = \frac{\mu_0 I}{4\pi} \frac{d\vec{\ell} \times \vec{a}}{a^3} \quad \text{(By Biot-Savart law)}$$

Using eqn. 8.6.1(a) and (b), the above gives:

$$= \frac{\mu_0 I}{4\pi a^3} \hat{k} \frac{a^2 d\theta}{a^3}$$

$$\Rightarrow \vec{dB} = \hat{k} \frac{\mu_0 I}{4\pi a} d\theta \quad \dots 8.6.1$$

It is seen that \vec{dB} due to all other elements of the loop is in the same direction which is that of Z-axis and is out of the plane of the paper. As all elements of the loop are on its circumference, the total field \vec{B} due to the entire loop is obtained by integrating eq. 8.6.1.

$$\text{Thus } \vec{B} = \hat{k} \int_0^{2\pi} \frac{\mu_0 I}{4\pi a} d\theta$$

$$\Rightarrow \vec{B} = \hat{k} \frac{\mu_0 I}{4\pi a} \times 2\pi = \hat{k} \frac{\mu_0 I}{2a} \quad \dots 8.6.2$$

It is to be noted that if the current is clock wise then $\vec{dl} = -dx\hat{i} - dy\hat{j}$ and

$$\vec{B}_N = -\frac{\mu_0 NI}{2a} \hat{k} \quad \dots 8.6.3$$

It is seen that the direction of \vec{B} at the centre of the loop is as per right hand thumb rule as shown in Fig. 8.13 i.e. "If the current is in anticlockwise sense, the field is towards the viewer and if it is in clockwise sense it is away from the viewer."

Ex. 8.6.1 Calculate the magnetic induction at the centre of a flat circular coil of 100 turns of wire and 15 cm radius when it carries a current of 6 amps in anticlockwise sense. What would be the magnetic field if the same coil is rewound to have 200 turns?

Soln.

Given that $I = 6 \text{ A}$
 $a = 15 \text{ cm} = 0.15 \text{ m}$
 and $N = 100$

$$\vec{B} = \hat{k} \frac{\mu_0 NI}{2a}$$

(assuming the coil in XY plane)

$$\text{i.e. } |\vec{B}| = \frac{\mu_0 NI}{2a}$$

$$= \frac{\mu_0}{4\pi} \frac{2\pi NI}{a}$$

$$= 10^{-7} \frac{\text{Wb}}{\text{A.m}} \times 2 \times \frac{22}{7} \times \frac{100 \times 6 \text{ A}}{0.15 \text{ m}}$$

$$= 2.5 \times 10^{-3} \text{ Tesla}$$

The direction of \vec{B} is perpendicular to the plane of the coil and is determined by right hand thumb rule.

When the coil is rewound to have 200 turns let the new radius of the coil be a' . Then

$$2\pi Na = 2\pi N' a'$$

$$\text{i.e. } 100 \times 0.15 \text{ m} = 200 a'$$

$$\Rightarrow a' = 0.15 \text{ m} \times \frac{100}{200} = 0.075 \text{ m}$$

$$\therefore B' = \frac{\mu_0 N'I}{2a'}$$

$$= 4\pi \times 10^{-7} \frac{\text{Wb}}{\text{A.m}} \times \frac{200 \times 6 \text{ A}}{2 \times 0.075 \text{ m}}$$

$$= 10 \times 10^{-3} \frac{\text{Wb}}{\text{m}^2} = 10^{-2} \text{ Tesla}$$

8.6 (b) Magnetic field at any point on the axis of a circular coil carrying current

Let us consider a circular coil of radius a and number of turns N in the XY plane which is taken as the plane of the paper. Then the axis of the coil becomes the Z-axis and let us take

the centre of the coil as the origin of the co-ordinate system as shown in Fig. 8.14.

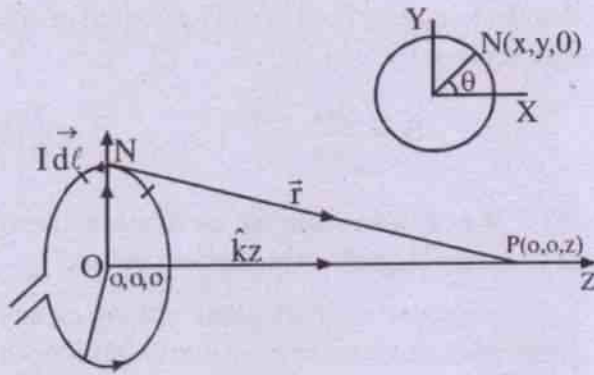

Fig. 8.14 (Magnetic induction at any point on the axis of a circular coil carrying current)

In order to calculate \vec{B} at any point P

$(0, 0, Z)$ on the axis, consider an element $I d\vec{\ell}$ at $N(x, y, 0)$ of coil. The magnetic field due to this element is given as

$$d\vec{B} = \frac{\mu_0 I}{4\pi} \frac{d\vec{\ell} \times \vec{r}}{r^3} \quad \dots 8.6.4$$

As shown in the diagram,

$$d\vec{\ell} = dx\hat{i} + dy\hat{j}; \quad \vec{r} = -x\hat{i} - y\hat{j} + z\hat{k}$$

$$r = \sqrt{x^2 + y^2 + z^2} = \sqrt{a^2 + z^2} \quad \dots 8.6.5$$

This gives

$$d\vec{\ell} \times \vec{r} = (xdy - ydx)\hat{k} - zdx\hat{j} + zdy\hat{i} \quad \dots 8.6.6$$

Since

$$x = a \cos \theta, y = a \sin \theta,$$

$$dx = -a \sin \theta d\theta, dy = a \cos \theta d\theta$$

So

$$d\vec{\ell} \times \vec{r} = \hat{k}a^2 d\theta + \hat{j}za \sin \theta d\theta + \hat{i}za \cos \theta d\theta \quad \dots 8.6.7$$

Using eqn. (8.6.7) in eqn. (8.6.6)

$$d\vec{B} = \frac{\mu_0 I}{4\pi} \frac{(\hat{k}a^2 d\theta + \hat{j}za \sin \theta d\theta + \hat{i}za \cos \theta d\theta)}{(a^2 + z^2)^{3/2}} \quad \dots 8.6.8$$

The net magnetic field due to entire loop is obtained by integrating eqn. (8.6.8).

$$\vec{B} = \int d\vec{B} = \frac{\mu_0 I}{4\pi} \frac{(\hat{k}a^2 \int_0^{2\pi} d\theta + \hat{j}za \int_0^{2\pi} \sin \theta d\theta + \hat{i}za \int_0^{2\pi} \cos \theta d\theta)}{(a^2 + z^2)^{3/2}} \quad \dots 8.6.9$$

$$\vec{B} = \int d\vec{B} = \frac{\mu_0 I}{4\pi} \frac{(\hat{k}a^2 2\pi + 0 + 0)}{(a^2 + z^2)^{3/2}}$$

$$\Rightarrow \vec{B} = \frac{\mu_0 I}{2} \cdot \frac{a^2}{(a^2 + z^2)^{3/2}} \hat{k} \quad \dots 8.6.10$$

If there are N number of terms then

$$\vec{B}_N = \frac{\mu_0 NI}{2} \frac{a^2}{(a^2 + z^2)^{3/2}} \hat{k} \quad \dots 8.6.11$$

It is to be noted that if the current is clock wise then $d\vec{\ell} = -dx\hat{i} - dy\hat{j}$ and

$$\vec{B}_N = -\frac{\mu_0 NI}{2} \frac{a^2}{(a^2 + z^2)^{3/2}} \hat{k}$$

This shows that $|\vec{B}|$ varies with distance z along the axis. It decreases as z increases in either side of the centre O. The direction of \vec{B} is along the axis of the coil and is out of its plane if the current sense is anticlockwise and into its plane if the current is clock wise.

At the centre of the coil $z=0$, so that

$$\vec{B} = \hat{k} \frac{\mu_0 N I}{2a}$$

Which is the same as obtained earlier in eq. 8.6.3. The variation of \vec{B} with distance z is shown graphically in Fig 8.15

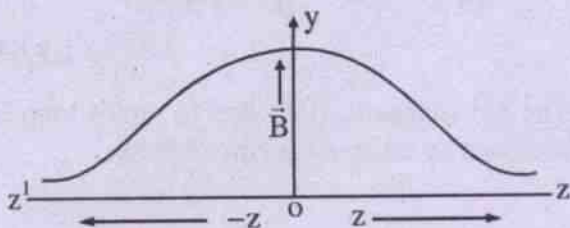

Fig. 8.15 Variation of \vec{B} with distance along the axis of a circular current.

8.7(a) Magnetic dipole moment of the coil and \vec{B} due to it.

The magnetic field at any point on the axis of a circular coil carrying current I is given by eq. 8.6.11 which may be written as

$$\vec{B} = \frac{\mu_0}{4\pi} \frac{2(NI\pi a^2 \hat{k})}{(a^2 + z^2)^{3/2}}$$

$$\Rightarrow \vec{B} = \frac{\mu_0}{4\pi} \frac{2\vec{m}}{(a^2 + z^2)^{3/2}} \quad \dots 8.6.12$$

Where we have written

$$\vec{m} = NI\pi a^2 \hat{k} \quad \dots 8.6.13$$

and let us call \vec{m} given by eq. 8.6.13 as the magnetic dipole moment of the current carrying circular coil. In fact eq. 8.6.13 was obtained earlier while finding the magnetic field at any point on the axis of a bar magnet. Thus we see that a current carrying coil behaves as a magnetic dipole. The magnetic moment of such a coil may be written as

$$\vec{m} = IA \hat{a} \quad \dots 8.6.14$$

Where A is the area of the coil and \hat{a} is outwardly drawn unit vector perpendicular to the area. For a circular coil carrying current $A = \pi a^2 N$ and $A \hat{a} = \pi a^2 N \hat{k}$ when the plane of

the coil is the XY plane, the current being in anticlockwise sense. From eq. 8.6.12 we see that the magnetic field at a distant point on the axis is given by

$$\vec{B} = \frac{\mu_0}{4\pi} \frac{2\vec{m}}{a^3} \quad \dots 8.6.15$$

(b) We can also calculate the dipole moment of a current loop directly as given below.

Consider a small plane circuit of any shape and calculate the field due to this loop at any point P , where the distance from the loop is large compared with the linear dimension of the circuit. Let 'o' be a point inside the circuit and be chosen as the origin. The coordinate axes X, Y, Z are so arranged that Z -axis is along the positive outward drawn normal to the circuit.

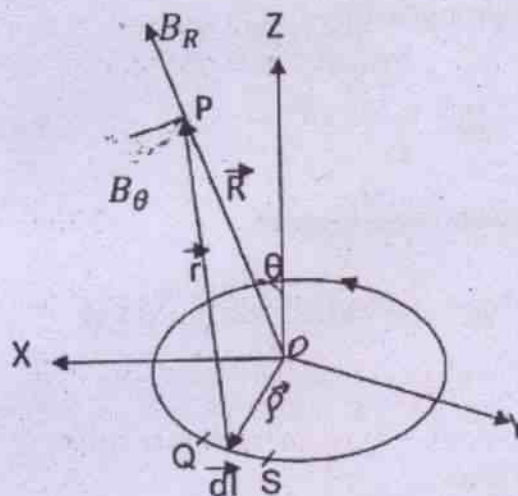

Fig. 8.71

Let \vec{OP} lie in the ZX -Plane. The circuit lies in the XY -Plane. Then

$$\vec{R} = R(\hat{x} \sin \theta + \hat{z} \cos \theta) \quad \dots (8.7.5)$$

$$\hat{R}(\theta) = \frac{\vec{R}}{R} = (\hat{x} \sin \theta + \hat{z} \cos \theta) \quad \dots (8.7.6)$$

$$\hat{\theta} \cdot \hat{R} = 0 \Rightarrow \hat{\theta} = \hat{x} \cos \theta - \hat{z} \sin \theta \quad \text{---(8.7.7)}$$

$$\vec{\rho} = \hat{x}x + \hat{y}y$$

$$(\because \rho \text{ lies in } xy\text{-plane}) \quad \text{---(8.7.8)}$$

Since x, y are small, so ρ is small. Further we find that $\vec{r} + \vec{\rho} = \vec{R}$ -----(8.7.9)

Eqn. 8.7.9 gives

$$\begin{aligned} r^2 &= R^2 + \rho^2 - 2R \cdot \rho = R^2 + \rho^2 - 2Rx \sin \theta \\ \Rightarrow r^2 &= R^2 \left(1 + \frac{\rho^2}{R^2} - \frac{2x}{R} \sin \theta\right) \cong R^2 \left(1 - \frac{2x}{R} \sin \theta\right) \\ \Rightarrow \frac{1}{r^2} &\cong \frac{1}{R^2 \left(1 - \frac{2x}{R} \sin \theta\right)} \Rightarrow \frac{1}{r^2} \cong \left(1 + \frac{3x}{R} \sin \theta\right) \end{aligned}$$

Now according to Biot and Savart's law the magnetic field at P due current element $d\vec{l} = (QS)$ is

$$d\vec{B} = \frac{\mu_0}{4\pi} \frac{i d\vec{l} \times \vec{r}}{r^3} \quad \text{---(8.7.11)}$$

Using eqn.8.7.9 and 10 in eqn.8.7.11 we obtain

$$d\vec{B} = \frac{\mu_0 i}{4\pi R^3} [d\vec{l} \times \vec{R} - d\vec{l} \times \vec{\rho} + \frac{3x}{R} \sin \theta d\vec{l} \times \vec{R} - \frac{3x}{R} \sin \theta d\vec{l} \times \vec{\rho}]$$

Retaining up to 2nd order smallness we get

$$d\vec{B} = \frac{\mu_0 i}{4\pi R^3} [d\vec{l} \times \vec{R} - d\vec{l} \times \vec{\rho} + \frac{3x}{R} \sin \theta d\vec{l} \times \vec{R}] \quad \text{---(8.7.12)}$$

Integrating around the circuit

$$\vec{B} = \frac{\mu_0 i}{4\pi R^3} [\oint (d\vec{l}) \times \vec{R} - \oint (d\vec{l} \times \vec{\rho}) + \frac{3}{R} \sin \theta (\oint x d\vec{l}) \times \vec{R}]$$

Now $\oint d\vec{l} = 0$, as the circuit is closed. Further if we consider the triangle OQS, then its area is $d\vec{a} = \frac{1}{2} \vec{\rho} \times d\vec{l}$ and its direction is along the Z-direction.

$$\text{Hence } \oint (d\vec{l} \times \vec{\rho}) = -2\vec{A} = -2\hat{z}A$$

$$\text{Further } d\vec{l} = \hat{x} dx + \hat{y} dy$$

Hence

$$\oint x d\vec{l} = \hat{x} \oint x dx + \hat{y} \oint x dy = \hat{x} \frac{x^2}{2} \Big|_x + \hat{y} A$$

$$\text{Giving } \oint x d\vec{l} = \hat{y} A$$

So using the above results finally eqn. 8.7.13 gives

$$\vec{B} = \frac{\mu_0 i}{4\pi R^3} [0 + 2\hat{z}A + \frac{3 \sin \theta}{R} (\hat{y}A \times \vec{R})] \quad \text{--- (8.7.15)}$$

Using eqn.8.7.5 we obtain

$$\vec{B} = \frac{\mu_0 i A}{4\pi R^3} [2\hat{z} + 3 \sin \theta (\hat{x} \cos \theta - \hat{z} \sin \theta)] \quad \text{---(8.7.16)}$$

Equation 8.7.16 gives

$$B_R = \hat{R} \cdot \vec{B} = \frac{\mu_0 i A}{4\pi R^3} \cos \theta \quad \text{---(8.7.17)}$$

$$\text{and } B_\theta = \hat{\theta} \cdot \vec{B} = \frac{\mu_0 i A}{4\pi R^3} \sin \theta \quad \text{---(8.7.18)}$$

Using eqn.8.7.6 and 8.7.7 we obtain

$$\vec{B} = B_R \hat{R} + B_\theta \hat{\theta} = \frac{\mu_0 i A}{4\pi R^3} [3(\hat{z} \cdot \vec{R}) \hat{R} - \hat{z}] \quad \text{---(8.7.19)}$$

Equations 8.7.17, 18 and 19 show that the field at a point at large distance from the loop of small dimension is same as that produced by a dipole of magnetic moment $\vec{M} = i\vec{A}$. From eqn.8.7.19 we obtain

$$B = \frac{\mu_0 i A}{4\pi R^3} \sqrt{1 + 3 \cos^2 \theta} \quad \text{---(8.7.20)}$$

Ex. 8.7.1 A closely wound circular coil of radius 10 cm and 50 turns produces a magnetic field of 2×10^{-4} tesla at a point P on its axis, the point being at a distance of 10 cm from its centre.

Calculate the current in the coil.

Soln.

Given that

$$a = 10 \text{ cm} = 0.1 \text{ m}$$

$$B = 2 \times 10^{-4} \text{ T} = 2 \times 10^{-4} \frac{\text{N}}{\text{A.m}}$$

$$N = 50 \text{ (no. of turns)}$$

$$Z = 10 \text{ cm} = 0.1 \text{ m}$$

$$\text{We have } B = \frac{\mu_0 N I a^2}{2(a^2 + z^2)^{3/2}}$$

$$\begin{aligned} \Rightarrow I &= \frac{2B(a^2 + z^2)^{3/2}}{\mu_0 N a^2} = \frac{2B(a^2 + z^2)^{3/2}}{4\pi \frac{\mu_0}{4\pi} N a^2} \\ &= \frac{2 \times 2 \times 10^{-4} \frac{\text{N}}{\text{A.m}} \frac{\text{N}}{\text{A.m}} (0.01 \text{ m}^2 + 0.01 \text{ m}^2)^{3/2}}{4\pi \times 10^{-7} \frac{\text{W}}{\text{A.m}} \frac{\text{N}}{\text{A.m}} 50 \times 0.01 \text{ m}^2} \\ &= \frac{10^3 \frac{\text{N}}{\text{A.m}} \times (0.02)^{3/2} \text{ m}^3}{\pi \frac{\text{W}}{\text{A.m}} 50 \times 10^{-2} \text{ m}^2} = 1.8 \text{ A} \end{aligned}$$

8.8 Magnetic dipole moment of a revolving electron:

In chapter-16, we shall read about the Bohr model of hydrogen atom, wherein it is postulated that electrons move in circular orbits about the nucleus.

We know that a moving charge is equivalent to a current. So the electron with charge $(-e)$ ($e = 1.6 \times 10^{-19}$ Coulomb) perform circular motion around the nucleus. This constitutes the current.

$$i = \frac{|e|}{T} \quad \text{-----(8.8.1)}$$

Where T is the time period of revolution. Now

$$\text{the period of revolution is } T = \frac{2\pi r}{v} \quad \text{-----(8.8.2)}$$

Where v is the speed of electron on the orbit, and r is the radius of the orbit. Using eqn. 8.8.2 in eqn. 8.8.1 we obtain

$$i = \frac{|e|v}{2\pi r} \quad \text{-----(8.8.3)}$$

As discussed in previous section 8.7 a current loop is equivalent to a magnetic dipole of dipole moment iA , so

Dipole moment

$$|\vec{m}| = i|\vec{A}| = i\pi r^2 = \frac{|e|v}{2\pi r} \pi r^2 = \frac{|e|vr}{2} \quad \text{-----(8.8.4)}$$

Where m_e is the mass of the electron and $m_evr = l$, is the orbital angular momentum of the electron. So we write

$$|\vec{m}| = \frac{|e|}{2m_e} l$$

$$\text{Givign } \vec{m} = -\frac{e}{2m_e} l \quad \text{-----(8.8.5)}$$

Where \vec{l} is directed in the opposite direction of m , i.e. along the outward drawn normal. The negative sign indicates the negative charge carried by the electron. Further

$$\frac{m}{l} = \frac{e}{2m_e} \quad \text{-----(8.8.6)}$$

is called the gyromagnetic ratio and is a constant. Its value is 8.8×10^{10} C/kg for an electron. This has been verified by experiment.

The above analysis suggests that even at atomic level there is a magnetic moment and thus supports the existence of atomic magnetic moment.

Within Bohr model

$$l = n\hbar = \frac{n\hbar}{2\pi} \quad \text{-----(8.8.7)}$$

Where h is Planck's constant ($h = 6.626 \times 10^{-34} \text{ J.S}$),
 $n = 1, 2, 3, \dots$ etc. Hence taking $n = 1$, (for the
 lowest orbit)

$$l = \frac{h}{2\pi} = \frac{6.626 \times 10^{-34} \text{ J.S}}{2\pi} = 1.0546 \times 10^{-34} \text{ J.S}$$

$$\text{and } (m_l)_{\min.} = \frac{e}{2m_e} l = 9.27 \times 10^{-24} \text{ Am}^2$$

Where $(m_l)_{\min.}$ is the minimum orbital magnetic moment.

8.9 The Magnetic field at any point on the axis of a solenoid.

A long wire wound in the form of a closely spaced spiral over a nonconducting hollow cylindrical core is called a solenoid (vide fig. 8.16). Usually its length is large in comparison with its diameter. It can be shown that the magnetic field inside a very tightly wound long solenoid carrying a steady current, is uniform at every point on its axis and is nearly zero outside.

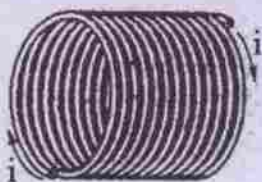

Fig. 8.16 (A solenoid carrying current)

Since the solenoid is made up a large number of similar, coaxial circular turns the magnetic field lines due to any two adjacent turns oppose each other at any outside point whereas these are in the same direction at any inside point. This gives rise to a strong uniform field at any inside point. These lines of force have been shown in Fig. 8.17.

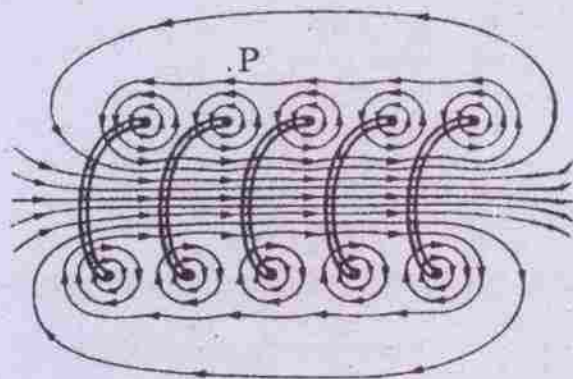

Fig. 8.17

The magnetic field lines in a vertical cross section through the central axis of a "stretched-out" solenoid are shown in Fig. 8.17. The back portions of five turns are shown. Each turn produces circular magnetic field lines near it. Near the solenoid's axis, the field lines combine into a net magnetic field that is directed along the axis. The closely spaced field lines there indicate a strong magnetic field. Outside the solenoid the field lines are widely spaced, the field there being very weak.

Quantitatively the magnetic field at any point on the axis of the solenoid can be calculated assuming that any small element of its length is equivalent to a circular coil of several turns.

Let us consider a solenoid of radius 'a' and length L having N number of closely packed turns wound over it, (Fig. 8.18). Let the axis of the solenoid be the x-axis of the co-ordinate system. Let us take an infinitesimally small element of length Δx having its centre at O. QQ' is the length Δx of the small element. P is a point on the axis of the solenoid at an axial distance x from O. Let the distance QP \cong Q'P be

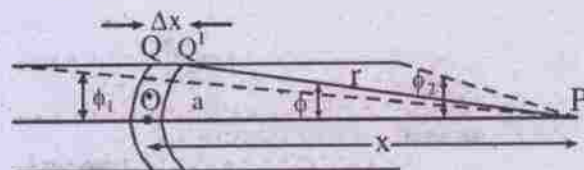

Fig. 8.18 (a)

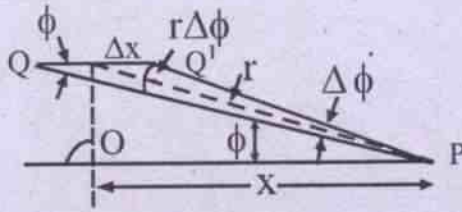

Fig. 8.18 (b)

r. The no. of turns within the small length $\Delta x = \frac{N\Delta x}{L}$. Clearly the infinitesimal length Δx of the solenoid is equivalent to a circular coil of radius a and no. of turns $\frac{N}{L}\Delta x$. Then assuming that the sense of charge flow in the solenoid is anticlockwise the magnetic field at P due to this small element of length Δx can be obtained by using eq. 8.6.11. Let us take this field to be $\vec{\Delta B}$. Obviously

$$\vec{\Delta B} = \hat{i} \frac{\mu_0 I a^2}{2r^3} \cdot \frac{N}{L} \Delta x \quad 8.9.1$$

Taking its magnitude only and integrating it for the whole length of the solenoid we shall obtain

$$B = \int \frac{\mu_0 I a^2}{2r^3} \frac{N}{L} dx \quad \dots 8.9.2$$

(Assuming that $\Delta x \rightarrow dx$, so that $\Delta B \rightarrow dB$) and $\Delta\phi \rightarrow d\phi$

To integrate the R.H.S. of eq. 8.7.2 let us use the diagram 8.18 b and express dx and r in terms of a single variable ϕ . From Fig. 8.18 b it is seen that

$$\begin{aligned} \sin \phi &= \frac{r d\phi}{dx} \\ \Rightarrow dx &= \frac{r d\phi}{\sin \phi} \quad \dots 8.9.3 \end{aligned}$$

$$\text{Also } \frac{a}{r} = \sin \phi \quad \dots 8.9.4$$

Then eq. 8.7.2 is converted to

$$B = \frac{\mu_0 I N}{2L} \int_{\phi_1}^{\phi_2} \sin \phi d\phi \quad \dots 8.9.5$$

Where ϕ_1 and ϕ_2 are the angles made by initial and final end points of the solenoid at P. The integration, on evaluation, gives

$$B = \frac{\mu_0 I N}{2L} [\cos \phi_1 - \cos \phi_2] \quad \dots 8.9.6$$

If the solenoid is long enough and point P is within it, $\phi_1 \rightarrow 0$ and $\phi_2 \rightarrow \pi$ so that,

$$\begin{aligned} B &= \frac{\mu_0 I N}{2L} \times 2 \\ \Rightarrow \vec{B} &= \hat{i} \frac{\mu_0 I N}{L} = \hat{i} \mu_0 n I \quad \dots 8.9.7 \end{aligned}$$

Where $n = \frac{N}{L}$ = no. of turns per unit length of the solenoid. Clearly the field is a uniform one and is independent of the location of P. This makes the solenoid useful when a strong uniform magnetic field is required in an experimental setup.

8.10 Bar magnet as an equivalent Solenoid:

We have seen in sec.8.9 that the magnetic field due to a current carrying solenoid, consisting of 'N' turns and length L is given as (using eqn.8.9.1)

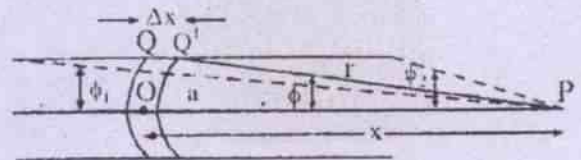

Fig.8.10.1

$$\vec{B} = \hat{i} \int_{-d}^{l-d} \frac{\mu_0 N i a^2}{2r^3} dx = \hat{i} \int_{-d}^{l-d} \frac{\mu_0 N i a^2}{2L(a^2 + X^2)^{3/2}} dx$$

Since $X \gg a$, so the above expression reduces to

$$\vec{B} = \hat{i} \int_{-d}^{l-d} \frac{\mu_0 N i a^2}{2X^3 L} dx = \hat{i} \frac{\mu_0 N i a^2}{2X^3 L} \int_{-d}^{l-d} dx = \hat{i} \frac{\mu_0 N i a^2}{2X^3 L} \cdot L$$

$$\text{Giving } \vec{B} = \hat{i} \frac{\mu_0 N i a^2}{2X^3} = \hat{i} \frac{\mu_0 N i \pi a^2}{2\pi X^3}$$

$$\text{If we define } \vec{m} = N i \pi a^2 \hat{i} = N i A \hat{i}$$

As the magnetic moment of the solenoid, then

$$B = \frac{\mu_0}{4\pi} \cdot \frac{2m}{X^3}$$

The expression 8.10.4 is identical with the expression 4.14.3 which is the magnetic field due to a bar magnet at a far off point. Thus a bar magnet and a solenoid produce similar fields at far off axial points. Hence we conclude that the magnetic moment of a bar magnet is equal to the magnetic moment of an equivalent solenoid that produces the same magnetic field. Thus a bar magnet is equivalent to a solenoid.

8.11 Ampere's circuital law

This law formulated by A.M. Ampere gives an alternative method to find \vec{B} due to a current distribution. It is quite convenient to use in certain specific cases where the geometry of current circuit is symmetrical.

The law states that "The tangential component of \vec{B} i.e. B_t summed over the elements of any closed path is equal to μ_0 times the total current across the area within the path."

$$\text{Mathematically } \sum_{i=1}^N B_t \Delta \ell_i = \mu_0 \sum_{i=1}^{N'} I_i \quad \dots 8.11.1$$

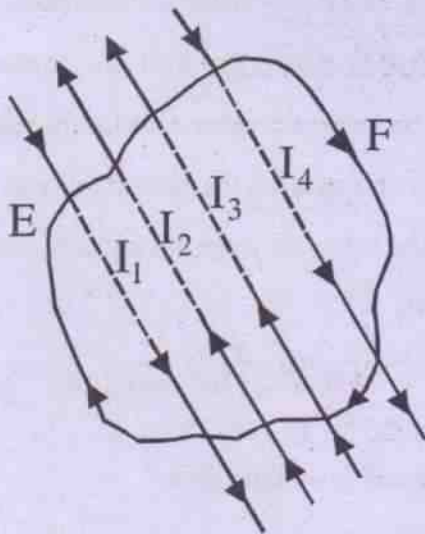

Fig. 8.19 (An Amperian loop enclosing currents)

Here the net current across the area A means the algebraic sum of currents in either directions through the area. To find the sum of these currents we proceed as follows.

- (1) A suitable closed curve called 'Amperian loop' is drawn to enclose all currents within it and a sense is assigned to the curve by giving an arrow mark at any point. This gives whether the curve is described in clockwise or in anticlockwise sense as seen by the viewer.
- (2) The direction of the area vector \hat{n} is then obtained following the right hand screw rule.
- (3) The currents in the same sense as \hat{n} are taken as positive and in the opposite sense are taken as negative.

One such Amperian loop is shown in Fig. 8.19. There are four currents within the loop and following the conventions mentioned as above we have from Ampere's law

$$\sum_{i=1}^N B_t \Delta \ell_i = -I_1 + I_2 + I_3 - I_4 \quad \dots 8.11.2$$

Obviously, if the curve does not enclose any current then

$$\sum_{i=1}^N B_t \Delta \ell_i = 0$$

When the number of elements $\Delta \ell_i$ of the path are infinitesimally small, the summation in eq. 8.8.1 is replaced by integration and we have

$$\oint \vec{B} \cdot d\vec{\ell} = \mu_0 \sum I_i \quad \dots 8.11.3$$

where the integration symbol in the L.H.S. means the integration over the closed loop.

Application

(i) To find B due to a long straight current

The result we have obtained in equation 8.5.5 for the magnetic field B due to a straight current carrying conductor of large length, can also be obtained by using Ampere's law if we take the Amperian loop around the conductor to be a circular path of radius s which is the distance of the point from the conductor as shown in fig. 8.20.

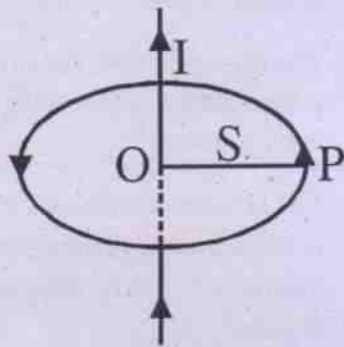

(\vec{B} due to a straight current by Ampere's law)

Fig. 8.20

When the loop is described in anticlockwise sense in a plane perpendicular to the conductor the area vector points upwards which has been the sense of current to as shown in the figure. Since we know that the magnetic lines of induction in such situation are concentric circles, the field vector at every point of the loop is tangential to the loop and we have

$\oint \vec{B} \cdot d\vec{\ell} = \oint B d\ell = \mu_0 I$ from Ampere's law.

$$\Rightarrow B \cdot 2\pi s = \mu_0 I$$

$$\Rightarrow B = \frac{\mu_0 I}{2\pi s} \quad \dots 8.11.4$$

Which is the result obtained earlier in eq. 8.5.5. Here the conductor is assumed to be of infinite extension.

(ii) \vec{B} due to a solenoid at any point inside it.

Fig. 8.21 gives the longitudinal section of a solenoid as described in the previous section.

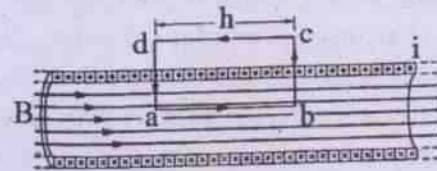

Fig. 8.21

Let us apply Ampere's law to a section of a long ideal solenoid carrying a current I . The Amperian loop is the rectangle $abcd$.

Qualitatively the magnetic lines of induction due to a steady current in the solenoid are closed parallel lines inside it. Such lines are wide apart outside as shown in Fig. 8.17. This nature of the magnetic field becomes convenient enough to find B inside the solenoid. Here we choose the Amperian loop to be a rectangular curve $abcd$ as shown in Fig. 8.21. For such a loop

$$\oint_{abcd} \vec{B} \cdot d\vec{\ell} = \int_a^b \vec{B} \cdot d\vec{\ell} + \int_b^c \vec{B} \cdot d\vec{\ell} + \int_c^d \vec{B} \cdot d\vec{\ell} + \int_d^a \vec{B} \cdot d\vec{\ell}$$

clearly \vec{B} and $d\vec{\ell}$ are in the same direction over ab whereas over bc and da these are perpendicular to each other. Outside the solenoid and over the path cd the field is almost zero. Hence the integrals over the paths bc , cd and da vanish.

$$\text{Hence} \quad \oint \vec{B} \cdot d\vec{\ell} = \int_a^b B d\ell = \mu_0 I \ell n \quad \dots 8.11.5$$

by Ampere's law. This gives

$$B \ell = \mu_0 I \ell n$$

$$\therefore B = \mu_0 n I \quad \dots 8.11.6$$

Where $n = \frac{N}{L}$ = no. of turns per unit length of the solenoid and $ab = \ell$. For anticlockwise current in each turn of the solenoid we may write

$$\vec{B} = \hat{i} \mu_0 \frac{N}{L} I = \hat{i} \mu_0 n I, \quad \dots 8.11.7$$

for a point inside the solenoid assuming its length to be parallel to x-axis.

It is to be noted that eq. 8.8.6 for the magnetic field inside the solenoid can be safely used only when the solenoid is long enough i.e. when its length is at least nearly five to six times its diameter.

(iii) **\vec{B} due to a toroid at any point inside it.**

A solenoid bent in the form of a circle becomes a toroid as shown in Fig. 8.22. It is obtained by winding a long wire closely on a nonconducting ring. The magnetic field inside a toroid can be obtained by applying Ampere's law.

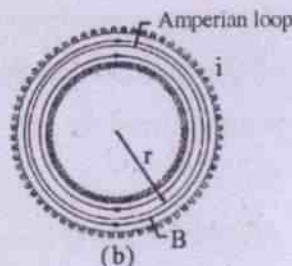

(a) A toroid carrying a current i .
(b) The toroid's cross section.

Fig. 8.22

Here the Amperian loop is chosen to be a concentric circle of radius s where $r_1 < s < r_2$ and r_1 and r_2 are the internal and external radii respectively. The point P inside the toroid is at a distance s from its centre. The field will have equal magnitude at all points of the Amperian loop. Hence by Ampere's law

$$\int \vec{B} \cdot d\vec{\ell} = \mu_0 I$$

$$\Rightarrow 2\pi s B = \mu_0 I$$

$$\Rightarrow B = \frac{\mu_0 I}{2\pi s}$$

If the toroid has N no. of turns, then

$$B = \frac{\mu_0 N I}{2\pi s} \quad \dots 8.11.8$$

At the inner edge of the toroid the magnetic field is the maximum and gradually falls off towards the outer edge.

Ex. 8.8.1 A long solenoid is fabricated by closely winding a wire of radius 0.5 mm over a cylindrical nonmagnetic frame so that the successive turns nearly touch each other. What would be the magnetic field B at the centre of the solenoid if it carries a current of 5A.

Soln.

$$\text{Diameter of the wire} = \text{width of the wire} \\ = 1 \text{ mm} = 10^{-3} \text{ m}$$

Hence no. of turns per metre of solenoid

$$= n = \frac{1}{10^{-3} \text{ m}} = 1000 \text{ per m.}$$

$$I = 5 \text{ A.}$$

$$\therefore B \text{ at the centre of the solenoid} = \mu_0 n I$$

$$= 4\pi \times 10^{-7} \frac{\text{N}}{\text{A}^2} \times 10^3 \frac{1}{\text{m}} \times 5 \text{ A} = 2\pi \times 10^{-3} \frac{\text{N}}{\text{Am}} \\ = 6.28 \times 10^{-3} \text{ Tesla.}$$

8.12 The Lorentz force

We have discussed earlier that a moving charge q experiences magnetic force while moving in a magnetic field \vec{B} , in a direction other than the direction of \vec{B} . The force is named magnetic force to differentiate it from the electric force experienced by the charge if the same region of space contains an electric field \vec{E} too. Denoting the electric and magnetic forces as \vec{F}_e and \vec{F}_m respectively, the net force

\vec{F} experienced by the charge is given by

$$\vec{F} = \vec{F}_c + \vec{F}_m$$

$$\text{i.e. } \vec{F} = q\vec{E} + q(\vec{v} \times \vec{B}) \quad \dots 8.12.1$$

The force \vec{F} is called **Lorentz force**.

It is of interest to find the work done by

Lorentz force for a small displacement $\vec{\Delta\ell}$ of the charged particle in a small time interval Δt . Such work ΔW is given by

$$\begin{aligned} \Delta W &= \vec{F} \cdot \vec{\Delta\ell} \\ &= \{q\vec{E} + q(\vec{v} \times \vec{B})\} \cdot \vec{\Delta\ell} \\ &= q\vec{E} \cdot \vec{\Delta\ell} + q(\vec{v} \times \vec{B}) \cdot \vec{\Delta\ell} \\ &= q\vec{E} \cdot \vec{v} \Delta t + q(\vec{v} \times \vec{B}) \cdot \vec{v} \Delta t \\ &\quad (\because \vec{\Delta\ell} = \vec{v} \Delta t) \\ \Rightarrow \Delta W &= q\vec{E} \cdot \vec{v} \Delta t \quad \dots 8.12.2 \end{aligned}$$

Since $(\vec{v} \times \vec{B})$ is perpendicular to \vec{v} .

Thus it is seen that the work done by Lorentz

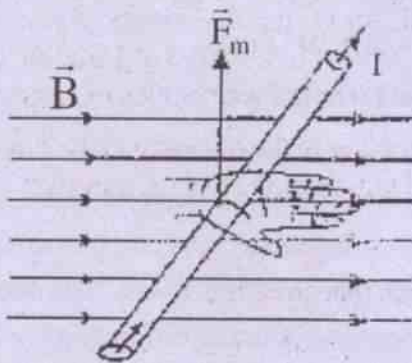

force on a moving charged particle is equal to that done by the electric force on it. The magnetic force does no work on the moving charged particle.

8.13 Motion of a charged particle in a uniform magnetic field.

Let us assume that a charged particle of charge q and mass m moves in a uniform magnetic field \vec{B} in a region where no other force acts on the particle. Hence the total force on it is the magnetic force only.

$$\text{i.e. } \vec{F} = \vec{F}_m$$

Since no work is done by magnetic force on the moving charged particle, its kinetic energy does not change. It implies that its speed v remains constant. However, the particle is accelerated at every moment since the force \vec{F}_m continues to work on it. This force simply changes the direction of motion of the particle at every instant and is perpendicular to the direction of the instantaneous velocity. One may recollect that the situation is the same as that of a uniform circular motion in a plane.

Thus the charged particle in a uniform magnetic field performs uniform circular motion in a plane which is perpendicular to the plane of \vec{v} and \vec{B} . The plane of motion of the particle is the plane of \vec{v} and \vec{F}_m .

The magnetic force \vec{F}_m , in this case, acts as the centripetal force and we may write the centripetal acceleration ' \vec{a}_c ' as

$$\begin{aligned} \vec{a}_c &= \frac{\vec{F}_m}{m} = \frac{q(\vec{v} \times \vec{B})}{m} \\ \Rightarrow \vec{a}_c &= \hat{n} \frac{qvB \sin \theta}{m} \quad \dots 8.13.1 \end{aligned}$$

Here \hat{n} is unit vector in the direction of \vec{F}_m . Fig. 8.23 illustrates the situation. Here the uniform magnetic field \vec{B} is shown to be in a direction perpendicular into plane of the diagram away from the viewer. It is shown by the symbol \otimes . The path of motion of the particle is

circular. The centripetal force $\vec{F}_c = \vec{F}_m$
 $= \hat{n}q\mathcal{G}\sin 90^\circ$

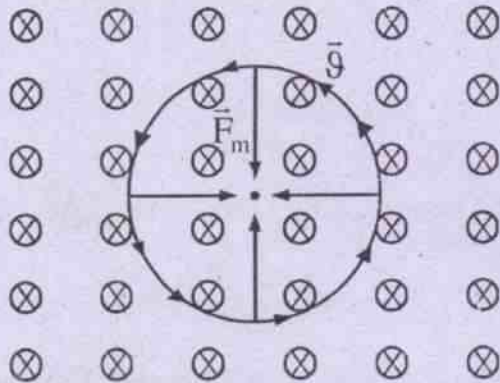

A charged particle moving in a uniform field (\vec{B}) performs circular motion.

Fig. 8.23

$$\Rightarrow \vec{F}_c = \hat{n}q\mathcal{G}B$$

the centripetal accn. $a_c = \hat{n} \frac{q\mathcal{G}B}{m}$...8.13.2

If r is the radius of the circular path described by the particle

$$a_c = \frac{\mathcal{G}^2}{r} = \frac{q\mathcal{G}B}{m}$$

$$\Rightarrow r = \frac{m\mathcal{G}}{qB}$$
 ...8.13.3

This shows that the radius of the path is proportional to speed \mathcal{G} of the charged particle. The time period of revolution of the particle is given by

$$T = \frac{2\pi r}{\mathcal{G}} = \frac{2\pi m\mathcal{G}}{qB\mathcal{G}}$$

$$\Rightarrow T = \frac{2\pi m}{qB}$$
 ...8.13.4

Clearly the time period of revolution is independent of the speed on the trajectory of the particle. The frequency of revolution of the particle is $qB/2\pi m$.

In the above discussion if $\vec{\mathcal{G}}$ is not perpendicular to \vec{B} and the particle moves in a direction making angle θ with \vec{B} , then $\vec{\mathcal{G}}$ is resolved into two components (i) $\mathcal{G}_{\parallel} = \mathcal{G}\cos\theta$ in the direction of \vec{B} . and (ii) $\mathcal{G}_{\perp} = \mathcal{G}\sin\theta$ perpendicular to \vec{B} . The component $\mathcal{G}\sin\theta$ becomes the cause of the circular motion of the particle whereas the other one $\mathcal{G}\cos\theta$ makes it shift parallel to B during each revolution. As a result the path of the particle becomes helical. This is shown in Fig. 8.24.

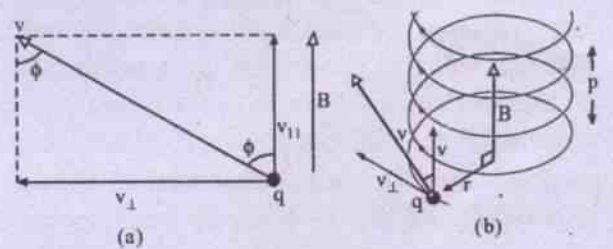

A charged particle moving in a helical path when $\vec{\mathcal{G}}$ is not \perp to \vec{B} .

Fig. 8.24

Ex. 8.10.1 An α - particle moves in a uniform magnetic field of induction 1.2 T in a circle of radius 49 cm. The plane of motion of the particle is perpendicular to the direction of \vec{B} . Find the speed and kinetic energy of the particle.

Soln.

Given that $q = 2e$
 $B = 1.2\text{T}$
 $r = 49\text{ cm} = 0.49\text{ m}$
 $\theta = 90^\circ$
 (the angle between $\vec{\mathcal{G}}$ and \vec{B})

For circular motion of the α -particle in the magnetic field

$$Bq\vartheta = \frac{m\vartheta^2}{r}$$

$$\Rightarrow \vartheta = \frac{Bqr}{m} = \frac{1.2\text{T} \times 2 \times 1.6 \times 10^{-19}\text{C} \times 0.49\text{m}}{4 \times 1.67 \times 10^{-27}\text{Kg}}$$

$$= 2.8 \times 10^7 \text{ m/S}$$

$$\therefore E_k = \frac{1}{2} m\vartheta^2$$

$$= \frac{1}{2} \times 4 \times 1.67 \times 10^{-27}\text{Kg} \times 2.8 \times 2.8 \times 10^{14} \frac{\text{m}^2}{\text{s}^2}$$

$$= 2.62 \times 10^{-12} \text{ J}$$

8.14 Magnetic force on a current carrying conductor.

A current carrying conductor has free electrons which drift along the conductor opposite to the direction of conventional current. It is equivalent to the drift of an equal amount of positive charge carriers in the direction of current. When the conductor is placed in a magnetic field \vec{B} , each of these mobile charges experiences a force \vec{F}' given by the equation,

$$\vec{F}' = e \vec{\vartheta}_d \times \vec{B} \quad \dots 8.11.1$$

Where $\vec{\vartheta}_d$ is the drift velocity of the charge carriers inside the conductor. \vec{B} in the region may or may not be uniform. However, for infinitesimally small length $d\ell$ of a conductor \vec{B} is taken to be uniform. If the cross sectional area of the conductor is A , the number of charge carriers within length element $d\ell = n A d\ell$, where $A d\ell$ is the volume of the element and n is the number of charge carriers per unit volume of the conductor. If the magnetic force on the

charge inside $A d\ell$ be $d\vec{F}_m$ then clearly

$$d\vec{F}_m = \vec{F}' n A d\ell$$

$$\Rightarrow d\vec{F}_m = e(\vec{\vartheta}_d \times \vec{B}) n A d\ell \quad \dots 8.14.2$$

Within the infinitesimal element $d\vec{\ell}$, the direction of $\vec{\vartheta}_d$ is parallel to $d\vec{\ell}$ so that we may write

$$\vec{\vartheta}_d d\ell = \vartheta_d d\vec{\ell}$$

Then from eq. 8.11.2, $d\vec{F}_m = e(d\vec{\ell} \times \vec{B}) n A \vartheta_d$

$$\Rightarrow d\vec{F}_m = I(d\vec{\ell} \times \vec{B}) \quad \dots 8.14.3$$

Where $I = n A e \vartheta_d = j A$, \vec{j} being the current density vector within the conductor.

For the whole of the conductor

$$\vec{F}_m = \int_0^{\vec{F}_m} d\vec{F}_m = \int_{\text{wire}} I(d\vec{\ell} \times \vec{B}) \quad \dots 8.14.4$$

If \vec{B} remains uniform in the region

$$\vec{F}_m = I \left(\int_{\text{wire}} d\vec{\ell} \right) \times \vec{B} \quad \dots 8.14.5$$

For a straight current carrying conductor in a uniform magnetic field \vec{B}

$$\vec{F}_m = I \int_0^{\vec{F}_m} d\vec{\ell} \times \vec{B} = I(\vec{\ell} \times \vec{B}) \quad \dots 8.14.6$$

The direction of the magnetic force is determined by right hand cork screw rule. **For example**, if a straight conductor carrying current is placed parallel to +ve x axis in a region where a uniform magnetic field \vec{B} is along +ve y axis, then the magnetic force on the conductor will be along +ve z-axis.

The following two rules may help the students to find the direction \vec{F}_m in an alternative way.

(a) Right hand rule

One's right hand being held flat with

- (i) fingers pointing in the direction of \vec{B} , and
 (ii) the thumb in the direction of current, the magnetic force \vec{F}_m will be in the direction in which the palm is pulled. This is shown in Fig. 8.25.

Right hand rule to find \vec{F}_m on a current carrying conductor.

Fig. 8.25

Here the current carrying wire and the magnetic field lie in one plane i.e. plane of the palm.

(b) **Fleming's Left Hand Rule**

If the thumb, the first finger and the middle finger of the left hand are stretched mutually perpendicular to one another with

- (i) the first finger in the direction of \vec{B} , and
 (ii) the middle finger in the direction of current,
 (iii) the thumb points in the direction of magnetic force \vec{F}_m on the conductor. This is shown in Fig. 8.26.

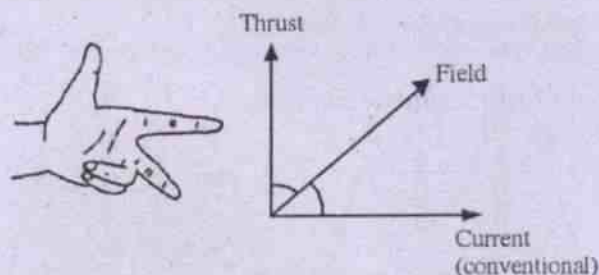
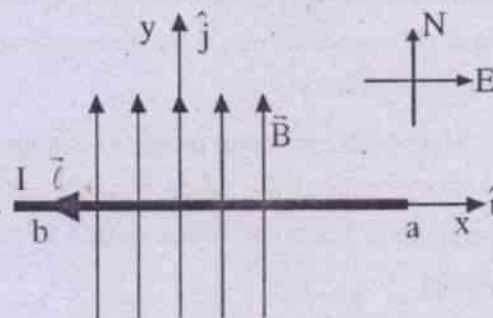

Fig. 8.26 Fleming's Left Hand Rule

From eq. 8.11.6 we see that (i) if the current carrying conductor lies perpendicularly to \vec{B} , it experiences the maximum magnetic force and (ii) if it lies along the direction of \vec{B} , it experiences no magnetic force.

Ex. 8.11.1 A straight conductor of 2m is placed in Earth's magnetic field horizontally. If a current of 0.5 A is maintained in it from east to west find the magnitude and direction of the magnetic force on the conductor. The horizontal component of earth's magnetic field is 0.36 gauss.

Soln.



Let us take

$$\vec{ab} = \vec{l} = 2(-\hat{i})\text{m}$$

(i.e. along -ve x-axis)

$$I = 0.5 \text{ A}$$

$$\vec{B} = 0.36 \hat{j} \text{ gauss}$$

$$= 0.36 \times 10^{-4} \hat{j} \text{ Tesla}$$

$$\therefore \vec{F}_m = I \vec{l} \times \vec{B}$$

$$= 0.5\text{A}(-\hat{i})2\text{m} \times \hat{j}(0.36 \times 10^{-4}\text{T})$$

$$= (-\hat{i} \times \hat{j}) 0.36 \times 10^{-4} \text{ N}$$

$$= -\hat{k} 0.36 \times 10^{-4} \text{ N}$$

i.e. the force on the conductor ab acts perpendicularly into plane of the diagram and is of magnitude 36×10^{-6} newton.

Force between two parallel current carrying conductors

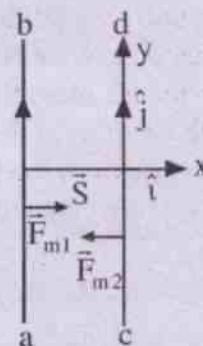

(Mutual force on two long, parallel and straight currents)

Fig. 8.26

As shown in Fig. 8.26, I_1 and I_2 are currents in two long, parallel straight conductors ab and cd respectively. Let the separation between them be S .

Here each conductor produces a magnetic field at any point on the other. Hence each one experiences a magnetic force which is to be found out.

Let us assume that \vec{ab} and \vec{cd} are along the y -axis which is the direction of charge flow in them. \vec{S} is along x -axis. Hence we may write

$$\vec{\ell}_1 = \vec{ab} = \hat{j} \ell_1$$

$$\vec{\ell}_2 = \vec{cd} = \hat{j} \ell_2$$

$$\text{and } \vec{S} = \hat{i}S$$

Then the magnetic field \vec{B}_1 produced by \vec{ab} at any point on cd is given by

$$\vec{B}_1 = \frac{\mu_0 I_1}{2\pi s} (-\hat{k}) \quad \dots 8.14.7$$

(using eq. 8.5.5)

\therefore The magnetic force on cd due to \vec{B}_1 is written as

$$\begin{aligned} \vec{F}_{m2} &= I_2 (\vec{\ell}_2 \times \vec{B}_1) \\ &= I_2 \left[\hat{j} \ell_2 \times (-\hat{k}) \frac{\mu_0 I_1}{2\pi s} \right] \\ &= -\hat{i} \frac{\mu_0}{2\pi s} I_1 \cdot I_2 \ell_2 \quad \dots 8.14.8 \end{aligned}$$

(using eq. 8.11.6)

Similarly the magnetic field \vec{B}_2 produced by cd at any point on ab is given by

$$\vec{B}_2 = \frac{\mu_0 I_2}{2\pi s} \hat{k} \quad \dots 8.14.9$$

Hence the magnetic force on ab is expressed as

$$\begin{aligned} \vec{F}_{m1} &= I_1 (\vec{\ell}_1 \times \vec{B}_2) \\ &= I_1 \left(\hat{j} \ell_1 \times \frac{\mu_0 I_2 \hat{k}}{2\pi s} \right) \\ &= (\hat{j} \times \hat{k}) \frac{\mu_0 I_1 I_2 \ell_1}{2\pi s} = \hat{i} \frac{\mu_0 I_1 I_2 \ell_1}{2\pi s} \quad \dots 8.14.10 \end{aligned}$$

From eqns. 8.14.8 and 8.14.10 it is seen that the magnetic forces on ab and cd are directed towards each other and it seems to be a case of mutual attraction.

If the currents in the two conductors are maintained in opposite directions, the forces can be seen to be directed away from each other. In other words the two conductors seem to repel each other.

The magnetic lines of force produced by the two currents are concentric circles in a plane perpendicular to the plane of the diagram i.e. they lie on the XZ plane. The resultant field pattern is shown in Fig. 8.27.

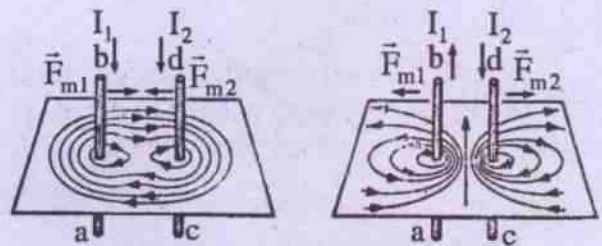

Fig. 8.26 (a) Resultant fields and forces between parallel current-carrying conductors. It is seen that when the charge flow in ab and cd are in the same direction, the lines of force due to them add up in the space between them. The resultant field thus becomes stronger in this region and weaker in the space outside the conductors. Each conductor is, therefore, forced to move from a region of weaker field to the stronger one. This results in attraction.

Similar analysis for two parallel and oppositely directed currents shows that the two conductors repel each other.

Definition of an Ampere :

Ampere is the S.I. unit of electric current. Its definition is based on the mutual magnetic force between two parallel, straight currents.

Let us take two very long straight conductors which carry two parallel currents. Let the separation between them be 1m. If each of the conductors carries current I , then the magnetic force per metre length of each is given by

$$F_m = \frac{\mu_0 I^2}{2\pi} \text{ n/m} \quad \dots 8.14.11$$

(using eqs. 8.14.8 and 8.14.10)

Assuming I to be 1 unit in each, the force can be written as $F_m = \frac{\mu_0}{2\pi} \frac{1}{1} = 2 \times 10^{-7} \text{ n/m}$.

Thus we define **one ampere** as that current which when maintained in two very long, straight and thin parallel conductors separated by one metre makes them attract each other by a force of 2×10^{-7} newton per metre.

8.15 Torque on a current loop in a uniform magnetic field

Consider a rectangular current loop ABCD with side lengths l and b . Let the plane of the coil be taken as XY - plane; with $\overline{CD} = b\hat{x}$, $\overline{AB} = -b\hat{x}$, $\overline{DA} = l\hat{y}$, $\overline{BC} = -l\hat{y}$.

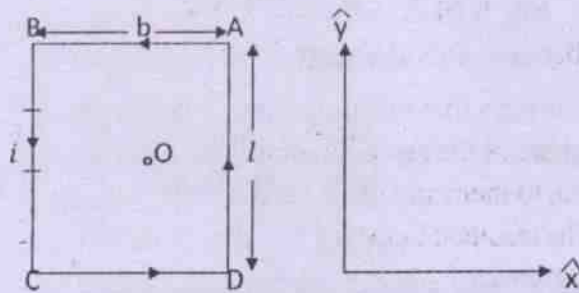

Fig.8.15.1

Then the area of the coil is $\vec{A} = lb\hat{z} = A\hat{z}$

Let a current ' i ' flow in the coil as shown in fig.8.15.1. Let the loop be kept in a uniform magnetic field \vec{B} . The effect of \vec{B} on the loop will depend on the orientation of the field of \vec{B} . So we now attempt to examine this for various orientation of \vec{B}

$$\text{Then } \vec{B} = (B_x\hat{x} + B_y\hat{y}) + B_z\hat{z} \equiv \vec{B}_{||} + \vec{B}_{\perp}$$

Where $B_y = B \sin \theta \sin \phi$, $B_x = B \sin \theta \cos \phi$

and $\vec{B}_{||} = (B_x\hat{x} + B_y\hat{y})$ is parallel to the plane of the coil and $\vec{B}_{\perp} = B_z\hat{z}$ is perpendicular to the plane of the coil.

The force on an element $d\vec{l}$ of the arm AB, shall be

$$d\vec{F}_{AB} = i(d\vec{l} \times \vec{B}) = i(-dx\hat{x} \times \vec{B}) = -idx[\hat{x} \times (B_x\hat{x} + B_y\hat{y} + B_z\hat{z})]$$

$$\text{Giving } d\vec{F}_{AB} = -idx[B_y\hat{z} - B_z\hat{y}] \quad \dots (8.15.3)$$

The net force on the arm AB shall be

$$\int_A^B d\vec{F}_{AB} = \vec{F}_{AB} = ib(B_z\hat{y} - B_y\hat{z}) \quad \dots (8.15.4)$$

Since the current in the arm CD is opposite to that in arm AB, so

$$\vec{F}_{CD} = -\vec{F}_{AB} \quad \dots (8.15.5)$$

In a similar manner we have

$$\vec{F}_{DA} = \int_D^A i dy\hat{y} \times \vec{B} = \int_D^A i dy\hat{y} \times (B_x\hat{x} + B_y\hat{y} + B_z\hat{z})$$

$$\text{Giving } \vec{F}_{DA} = il(B_z\hat{x} - B_x\hat{z}) \quad \dots (8.15.6)$$

Similarly considering the net force on arm BC shall be

$$\vec{F}_{BC} = -\vec{F}_{DA} \quad \dots (8.15.7)$$

The torque about the point O, (the centre of the coil) shall be

$$\begin{aligned} \vec{\tau}_0 &= \left(\frac{b}{2} \hat{x} \times \vec{F}_{DA} \right) + \left(-\frac{b}{2} \hat{x} \times \vec{F}_{BC} \right) \\ &+ \left(\frac{l}{2} \hat{y} \times \vec{F}_{AB} \right) + \left(-\frac{l}{2} \hat{y} \times \vec{F}_{CD} \right) \end{aligned}$$

Using eqns. 8.12.4,5,6 and 7 in the above we obtain

$$\vec{\tau}_0 = iAB_x \hat{y} - iAB_y \hat{x} \quad \text{-----(8.15.7)}$$

Eqns. 8.12.1 and 8.12.2 gives

$$\vec{\tau}_0 = i\vec{A} \times \vec{B} \quad \text{-----(8.15.8)}$$

But in case of an extended body torque about an axis is of relevance; hence we proceed to calculate torque about some convenient axis \hat{a} as

$$\tau_a = \hat{a} \cdot \tau_0 = \hat{a} \cdot (i\vec{A} \times \vec{B}) \quad \text{-----(8.15.9)}$$

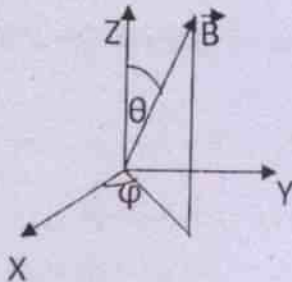

If $\hat{a} = \hat{x}$ then $\tau_x = \hat{x} \cdot \vec{\tau}_0 = -iAB_y = -iAB \sin \theta \sin \phi$ -----(8.15.10)

If $\hat{a} = \hat{y}$ then $\tau_y = \hat{y} \cdot \vec{\tau}_0 = iAB_x = iAB \sin \theta \cos \phi$ -----(8.15.11)

If $\hat{a} = \hat{z}$ then $\tau_z = \hat{z} \cdot \vec{\tau}_0 = 0$ -----(8.15.12)

Equation 8.12.12 shows that the perpendicular component of the magnetic field \vec{B}_\perp i.e.

$\vec{B}_\perp = B_z \hat{Z}$, does not contribute to the rotational torque. If the field lies in the XZ- plane, then $\phi = 0$ and $\tau_x = 0 = \tau_z$ and $\tau_y = iAB \sin \theta$.

Ex. 8.12.1 A 100 turn rectangular coil of sides 20cm and 15 cm is placed in a uniform magnetic field of $4 \times 10^{-2} \text{ W/m}^2$. Find the torque on the coil for a steady current of 100 mA when its plane remains parallel to the field and the 20cm side perpendicular to the field.

Soln.

Given that

$$N = 100$$

$$l = 20 \text{ cm} = 0.2 \text{ m}$$

$$b = 15 \text{ cm} = 0.15 \text{ m}$$

$$I = 100 \text{ mA} = 10^{-1} \text{ A}$$

$$B = 4 \times 10^{-2} \frac{\text{W}}{\text{m}^2} = 4 \times 10^{-2} \frac{\text{n}}{\text{Am}}$$

$$\theta = 0^\circ$$

\therefore The magnitude of the torque

$$\begin{aligned} \tau &= NIAB \cos \theta \\ &= 100 \times 10^{-1} \text{ A} \times (0.2 \times 0.15) \text{ m}^2 \times 4 \times 10^{-2} \frac{\text{n}}{\text{Am}} \\ &= 10^{-1} \times 3 \times 10^{-2} \times 4 \text{ nm} \\ &= 12 \times 10^{-3} \text{ mn} \end{aligned}$$

Ex.8.12.2 A current carrying coil of 50 turns experiences a maximum torque of 0.2 mn when placed in a uniform magnetic field of 0.05 T. Calculate the magnitude of magnetic dipolemoment of the coil and the current in it if its face area is 0.1 m^2 .

Soln.

Given that $N = 50$

$$|\vec{A}| = 0.1 \text{ m}^2$$

$$\tau_{\text{max}} = 0.2 \text{ mn}$$

$$B = 0.05 \text{ T} = 0.05 \text{ n/Am}$$

$$\therefore |\vec{m}| = \frac{\tau_{\text{max}}}{B} = \frac{0.2 \text{ mn}}{0.05 \frac{\text{n}}{\text{Am}}}$$

$$= 4 \text{ Am}^2$$

$$\text{and } I = \frac{|\vec{m}|}{N|\vec{A}|} = \frac{4 \text{ Am}^2}{50 \times 0.1 \text{ m}^2}$$

$$= 0.8 \text{ A}$$

8.16 The moving coil galvanometer :

A galvanometer is a device to detect current and sometimes to measure small current, when suitably calibrated.

Principle and theory:

It is based on the principle that when a loop carrying current is placed in a uniform magnetic field it experiences a torque, and the loop gets rotated about a suitable axis.

If 'N' be number of turns of a coil, 'i' be the current flowing in the coil, \vec{A} be the vector area of the coil and \vec{B} be the magnetic field, then the torque experienced by the loop about an axis defined by unit vector \hat{a} is given by (see eqn. 8.12.8)

$$\tau_a = \hat{a} \cdot (Ni \vec{A} \times \vec{B}) \quad \text{----(8.16.1)}$$

$$\text{Where } \vec{A} = A\hat{n} \quad \text{----(8.16.2)}$$

and \hat{n} is the outward drawn normal to the area. In case the plane of the coil coincides with the XY-plane (initially) described anticlockwise (current being anticlockwise), then $\hat{n} = \hat{z}$, i.e., the outward drawn normal is along Z-direction.

Now if the field \vec{B} lies in the XZ-plane, the plane of the coil coincides with the XY-plane (initially) and axis of rotation is Y-axis (i.e. $\hat{a} = \hat{y}$), then

$$\tau_y = \hat{y} \cdot [NiA\hat{z} \times (B_x\hat{x} + B_z\hat{z})] = \hat{y} \cdot [NiAB_x\hat{y}] = NiAB \sin \theta$$

$$\text{Thus } \tau_y = NiAB \sin \theta \quad \text{----(8.16.3)}$$

Where θ is the angle between the field \vec{B} and the normal to the plane of the coil ($\hat{n} = \hat{z}$) the Z-axis.

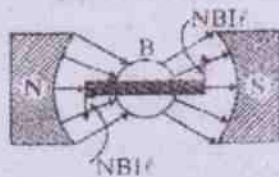

(Radial field produced by concave poles)

Fig.8.16.1

If the pole pieces of the magnets is made cylindrical so that the field is radial (see fig.8.16.1) and always parallel to the plane of the coil (i.e. perpendicular to the normal to the coil) i.e. $\theta = 90^\circ$, then

$$\tau_y = NiAB \quad \text{----(8.16.4)}$$

This couple tends to rotate the coil (about the axis of rotation) to a position at right angles to the field (i.e. the normal to the coil and the field are parallel). But this is prevented by an opposing torque developed due to twist of the wire (because of its elastic reaction). If 'c' be couple per unit twist of the suspension fibre and the coil rotates through α (so that the fibre is twisted through α) then in equilibrium position

$$\tau_y = NiAB = c\alpha \quad \text{----(8.16.5)}$$

$$\text{Givign } i = \left(\frac{c}{NAB} \right) \alpha \equiv k\alpha \quad \text{----(8.16.6)}$$

Where $k = \left(\frac{c}{NAB} \right)$ is a constant for a given galvanometer and is called as reduction factor of a moving coil galvanometer.

In case of pivoted type galvanometer the opposing torque arises due elastic reaction of the phosphor bronze spring holding the coil.

The measurement of the angle ' α ' are made as follows:

(a) Lamp and scale arrangement:

In this case when the suspension fibre rotates through ' α ' the mirror attached on the fibre rotates through α so that the reflected ray from the mirror rotates through 2α . As a result the light spot on the scale gets displaced through d, such that

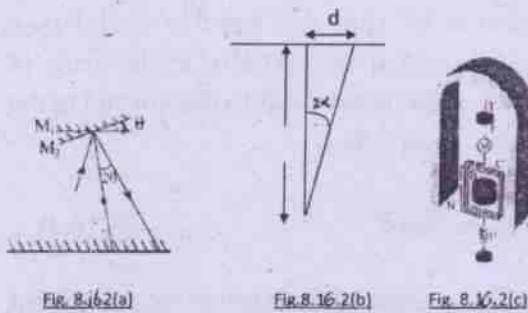

Fig. 8.16.2(a)

Fig. 8.16.2(b)

Fig. 8.16.2(c)

(Suspended coil galvanometer)

$$\tan 2\alpha = \frac{d}{D} \cong 2\alpha$$

$$\Rightarrow \alpha = \frac{d}{2D} \quad \text{---(8.16.7)}$$

$$\text{Therefore } i = \left(\frac{c}{NAB} \right) \alpha = \left(\frac{c}{2NABD} \right) d = k_1 d \quad \text{---(8.16.8)}$$

Thus the deflection 'd' of the spot on the scale is proportional to the current strength.

(b) Weston type galvanometer:

In this case an aluminium pointer is attached to the coil. The pointer gets deflected through 'd' as the coil rotates through α (see fig. 8.18.2). Hence

$$\tan \alpha = \frac{d}{D} \cong \alpha$$

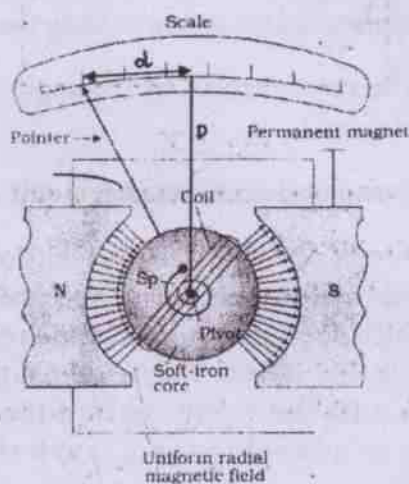

Fig. 8.16.3

$$\text{Giving } i = \left(\frac{C}{NABD} \right) d = k_2 d \quad \text{---(8.16.9)}$$

Constructions:

It consists of a coil having a large number of turns of this copper wire and wound on a soft iron core. The coil is suspended by means of a phosphor-bronze wire from a rigid support between two cylindrical pole pieces as shown in fig. 18.16.2(c). (i) A mirror is attached to the phosphor-bronze wire in case of lamp and scale arrangement. Light from a lamp falls on the mirror and the reflected spot from the mirror falls on a scale kept in front of the mirror. (ii) In case of Pivoted type (Weston type) an aluminium pointer is attached to the coil.

working:

(a) In case of lamp and scale arrangement; the lamp is adjusted so that when no current flows in the galvanometer, the light spot remains at the centre of the scale. Then the current is allowed to flow in the galvanometer and the deflection of the light spot on the scale is noted from which using eqn. 8.16.8 'i' can be calculated.

(b) in case of Pivoted type (Weston type) it is first of all observed that when no current flows through the galvanometer the aluminium pointer remains at the centre of the attached scale. Then the current is allowed and the deflection 'd' is observed. This is used in eqn. 8.16.9 to find the current 'i'.

Sensitivity of Galvanometer (Figure of Merit of Galvanometer):

(a) In case of lamp and scale arrangement '**Current sensitivity of the galvanometer is defined as the minimum current (in microampere) required to produce a deflection of the light spot through 1mm, on a scale fixed at a distance of 1 meter from the mirror attached on the fibre suspending the coil between the pole pieces**'. This is also called as **Figure of merit of galvanometer**.

Sensitivity = $k_1 = \frac{i}{d}$; d is the deflection of the light spot on the scale

(b) In case of Pivoted type (Weston type) "current sensitivity of the galvanometer is defined as the current in microampere required to produce 1mm deflection on the attached scale".

Sensitivity = $k_2 = \frac{i}{d}$, d is the deflection on the attached scale

A galvanometer is said to be more sensitive when its sensitivity is low.

Ex. 8.14.1: The coil of a pivoted coil galvanometer has 60 turns and has an area of 5 cm^2 . It swings in a radial magnetic field of 0.02 T . If the torsional constant of the spring is 10^8 mn find the angular deflection for a current of 1 mA in the coil. Calculate its "current sensitivity" and "Sensitivity".

Soln.

Given $N = 60$

$$|\vec{A}| = 5 \text{ cm}^2 = 5 \times 10^{-4} \text{ m}^2$$

$$|\vec{B}| = 0.02 \text{ Tesla}$$

$$C = 10^8 \text{ mn}$$

$$I = 1 \text{ mA} = 10^{-3} \text{ A}$$

$$\therefore \theta = \frac{I}{K} = \frac{NAB I}{C} \quad (\text{from eqs. 8.13.4 and 8.13.5})$$

$$\Rightarrow \theta = \frac{60 \times 5 \times 10^{-2} \text{ m}^2 \times 2 \times 10^{-2} \frac{\text{n}}{\text{Am}} \times 10^{-3} \text{ A}}{10^8 \text{ mn}}$$

$$= 6 \times 10^{-13} \text{ radians}$$

$$\text{Current Sensitivity} = S'_i = \frac{\theta}{I} = \frac{NAB}{C}$$

$$= \frac{60 \times 0.0005 \times 0.02}{10^8 \text{ mn}}$$

$$= \frac{6 \times 10^1 \times 5 \times 10^{-4} \times 2 \times 10^{-2}}{10^8}$$

$$= 6 \times 10^{-12} \text{ rad / Amp}$$

$$\text{Sensitivity} = S_i = \frac{1}{S'_i}$$

$$= \frac{1}{6 \times 10^{-12} \frac{\text{rad}}{\text{Amp}}}$$

$$= 0.167 \times 10^{12} \text{ Amp / rad}$$

Shunt :

A small current is sufficient to deflect the coil of a galvanometer. If a larger current is allowed to pass through it, the coil may burn. Hence while connecting a galvanometer in a circuit a suitable low resistance S is connected in parallel with the galvanometer coil to save it from damage. Such low resistance is called a shunt. A shunted galvanometer is shown in Fig.8.32.

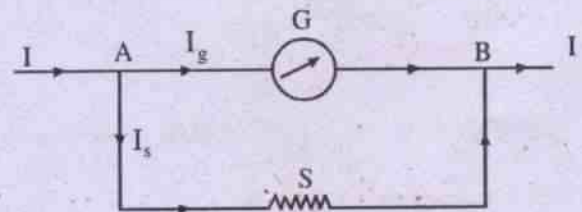

Fig. 8.32

(A galvanometer connected to a shunt S)

The main current I is divided at A into I_g and I_s which flow through the galvanometer and the shunt respectively. These two currents meet at B again to become I . The potential difference between A and B i.e. V_{AB} can be written as

$$V_{AB} = I_g G = I_s S$$

and $I = I_g + I_s$, so that $I_s = I - I_g$

$$\therefore V_{AB} = I_g G = (I - I_g) S$$

$$\Rightarrow I_g = \frac{S}{G+S} I \quad \dots 8.14.6$$

As $S \ll G$, I_g is a very small fraction of I and it saves the galvanometer from damage.

8.17 Conversion of galvanometer to ammeter:

An ammeter is an electrical device for measuring current in a circuit and is always used in series in a circuit.

A galvanometer can also measure current if suitably calibrated; but for a small current the pointer goes out of scale and a little considerable current may damage the galvanometer. Further as soon as the galvanometer is inserted in the circuit the current flowing in the circuit becomes different. For example consider the circuit shown in fig. 8.14.1, in which the current $i = \frac{E}{R}$ is to be measured. But when we insert the galvanometer of resistance G for measuring the current ' i ' we actually measure a current

$$i_1 = \frac{E}{R+G} = \frac{E}{R(1+\frac{G}{R})} \neq i$$

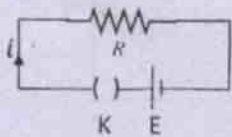

Fig. 8.17.1

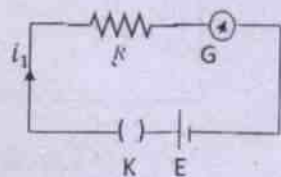

Fig. 8.17.2

So in order to enable the galvanometer measure current (i.e. work as an ammeter) its effective resistance should be reduced so that it affects the circuit to the minimum extent. This is achieved by connecting a shunt resistance in parallel to the galvanometer as discussed below.

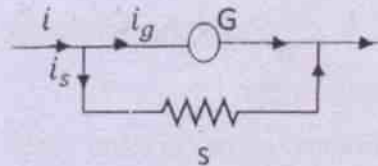

Fig. 8.17.3

The effective resistance G' is now given as

$$\frac{1}{G'} = \frac{1}{G} + \frac{1}{S} \text{ Giving } G' = \frac{GS}{G+S} = \frac{S}{1+\frac{S}{G}}$$

$$\text{-----(8.17.2)}$$

When $S \ll G$ we find $G' \cong S$, implying that the effective resistance of the galvanometer is greatly reduced and now current in the circuit is almost unaffected as shown below

$$i_1 = \frac{E}{R+G'} = \frac{E}{R(1+\frac{G'}{R})} \cong \frac{E}{R(1+\frac{S}{R})} \approx \frac{E}{R} = i$$

$$(\because S \ll R) \text{ ---(8.17.3)}$$

Further applying Kirchoff's law we have

$$i_g G = i_s S = (i - i_g) S \quad \text{-----(8.17.4)}$$

Solving this we obtain

$$i_g = i \frac{S}{G+S} = i \frac{S}{G(1+\frac{S}{G})} \cong i \frac{S}{G} \text{ ----(8.17.5)}$$

Equation 8.17.5 shows that a very small portion of the total current flows in the galvanometer and major portion of the current is by passed through the shunt. Thus the damage to the galvanometer is avoided. But this has now an added advantage of enhancement of the range of the galvanometer as discussed below.

Suppose $i_g^N = kN$ gives full scale deflection without causing damage and i_g^N is the safe value of the current, k is the current required to produce unit deflection on the scale.

Then from eqn.8.17.5 we have

$$\frac{i}{i_g} = \frac{G+S}{S} = 1 + \frac{G}{S} = N$$

This gives $S = \frac{G}{N-1}$ -----(8.17.6)

Equation 8.17.6 gives the value of the shunt resistance to increase the range of the galvanometer by N-times (when used as an ammeter), when the galvanometer resistance is G.

Ex. 8.16.2: A galvanometer is designed to give full scale deflection by a current of 0.1 A. If its coil resistance is 60 ohm, find the value of the resistance to be shunted with it to make it an ammeter reading upto 5A.

Soln.

Given that $I_g = 0.1$ A

$I = 5$ A

$G = 60 \Omega$

$S = ?$

We have $I = \left(\frac{G+S}{S}\right) I_g$

$\Rightarrow (I - I_g)S = I_g G$

$\Rightarrow S = \frac{I_g G}{(I - I_g)}$
 $= \frac{0.1A \cdot 60\Omega}{(5 - 0.1)A}$

$= 1.2\Omega$

8.18 Conversion of galvanometer to voltmeter :

A voltmeter is an electrical device used for measuring potential difference between two points in a circuit.

A galvanometer can be used to measure potential difference between two points by

calibrating the scale in terms of $V = i_g G$. But this has to be connected in parallel between two points and a little current should pass through the galvanometer to avoid any damage. For example if a current i passes through a resistance R , then P.D. across the resistance R is iR and it has to be measured. But as soon as the bare galvanometer is inserted, the current through R is disturbed and we fail to measure the actual P.D= iR ; but rather measures $i_g R = V_g \neq V$ as illustrated below.

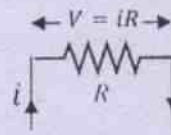

Fig.8.18.1

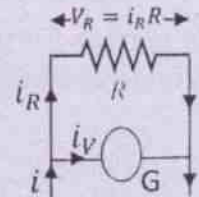
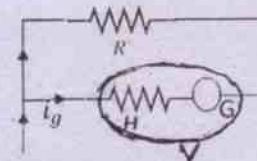

Fig.8.18.1

Thus we need that $i_R \rightarrow i$ and $i_g \rightarrow 0$. This in turn requires effective galvanometer resistance should be high. In order to achieve this condition a high resistance H is connected in series with the galvanometer as shown below.



The effective galvanometer resistance is

$G' = G + H$ -----(8.18.1)

and consequent effective resistance of the circuit is

$$R' = \frac{G'R}{G'+R} = \frac{R}{1 + \frac{R}{G'}} = \frac{R}{1 + \frac{R}{G+H}}$$

Since $(G + H) \gg R$ so $R' \cong R \Rightarrow$ almost no change in the current in the circuit. Now applying Kirchoff's law we get

$$i_R R = i_g (G + H) = (i - i_R)(G + H) \text{ ----(8.18.2)}$$

Its solution gives

$$i_R = i \frac{G + H}{R + (G + H)} = i \frac{1}{1 + \frac{R}{G + H}} \cong i$$

$$[\because (G + H) \gg R] \text{ ----(8.18.3)}$$

$$\text{This implies } i_R R \cong iR = V \text{ -----(8.18.4)}$$

i.e. the galvanometer measures the original P.D $iR = V$. Again we further find that if i_g^N be the safe current for the galvanometer then the maximum P.D measured is

$$V = i_g^N (G + H) = i_g^N \left(1 + \frac{H}{G}\right) = V_0 \left(1 + \frac{H}{G}\right) \text{ -----(8.18.5)}$$

Where $V_0 = i_g^N G$ is the old range of P.D that could be measured by the galvanometer. Now eqn. 8.18.5 gives

$$\frac{V}{V_0} = 1 + \frac{H}{G} = N$$

Giving the value of the high resistance

$$H = G(N - 1) \text{ -----(8.18.6)}$$

Thus the range is N-times increased.

Ex. 8.16.3: A moving coil galvanometer has a resistance of 40Ω . It gives full scale deflection with a current of 2 mA . How is it to be modified to convert it to a voltmeter of 5 volt range?

Soln.

$$\text{Given } G = 40 \Omega$$

$$i_g = 2 \times 10^{-3} \text{ A} = 0.002 \text{ A}$$

$$V_m = 5 \text{ V}$$

$$\text{We have } I_g R_v = 5 \text{ V}$$

$$\Rightarrow 0.002 \text{ A} (R_h + G) = 5 \text{ V}$$

$$\Rightarrow 0.002 R_h \text{ A} + 0.002 \times 40 \text{ V} = 5 \text{ V}$$

$$\Rightarrow 0.002 R_h \text{ A} = (5 - 0.08) \text{ V}$$

$$\Rightarrow R_h = \frac{4.92 \text{ V}}{0.002 \text{ A}} = 2460 \Omega$$

A resistance of 2460Ω is to be connected in series with the Galvanometer to convert it to a voltmeter of 5 V range.

Miscellaneous Numerical Examples

Ex. 1: A vertical straight wire in which a current of one ampere is maintained, is placed in the magnetic field of earth where the horizontal component of the field is $0.3 \times 10^{-4} \text{ tesla}$. Find the distance where the neutral point is obtained from the wire.

Soln.

The neutral point in this case is that point where the magnetic field of the straight conductor balances the horizontal component of the earth's magnetic field. Let the point be located at S from the straight conductor.

$$\text{Then } B_H = \frac{\mu_0 I}{2\pi S}$$

$$\Rightarrow S = \frac{\mu_0 I}{2\pi B_H}$$

Substituting the datas in the R.H.S.

$$S = 2 \times 10^{-7} \frac{\text{W}}{\text{A.m}} \frac{1 \text{ A}}{0.3 \times 10^{-4} \text{ T}}$$

$$= 6.67 \times 10^{-3} \frac{\text{Tm}^2 \text{ A}}{\text{A.m T}}$$

$$= 6.67 \times 10^{-3} \text{ m.}$$

Ex.2: A rectangle of size $50 \text{ cm} \times 40 \text{ cm}$ is placed horizontally in a uniform magnetic field which makes angle 45° with the vertical. Find the magnitude of the magnetic field if the flux over the rectangle is 0.17 Weber .

Soln.

Length of the rectangle = 50 cm = 0.5 m

Breadth of the rectangle = 40 cm = 0.4 m

$$\therefore \text{Area} = 0.20 \text{ m}^2$$

Assuming current to be maintained in clockwise sense the vector associated with A is in the vertically downward direction. Hence

$$\vec{A} = -0.2 \hat{k} \text{ m}^2$$

\therefore Angle between \vec{B} and $\hat{k} = 45^\circ$

$$\text{Magnetic flux } \phi = \vec{B} \cdot \vec{A} = |\vec{B}|A \cos 45^\circ$$

$$= 0.2 \frac{|\vec{B}|}{\sqrt{2}} \text{ m}^2$$

$$\Rightarrow 0.17 \text{ W} = \frac{0.2}{\sqrt{2}} B \text{ m}^2$$

$$\Rightarrow |\vec{B}| = \frac{0.17 \times \sqrt{2}}{0.20} \text{ W/m}^2$$

$$= 1.202 \text{ W/m}^2$$

Ex.3: A particle of mass 0.1g and charge $5 \times 10^{-10} \text{ C}$ is fired horizontally with speed 60 km/S. A horizontal magnetic field applied normally to the initial velocity direction of the particle keeps it moving undeviated along the horizontal path. Find the magnitude of the magnetic field. (neglect earth's magnetic field).

Soln.

Let the particle be fired horizontally along +ve X axis in the plane of the paper.

$$\begin{aligned} \text{Then velocity of the particle } \vec{v} &= 60 \frac{\text{km}}{\text{s}} \hat{i} \\ &= 6 \times 10^4 \hat{i} \frac{\text{m}}{\text{s}} \end{aligned}$$

Let the direction of the magnetic field \vec{B} be along +ve Y direction in the plane of the paper

$$\text{Then } \vec{B} = \hat{j}B$$

$$\therefore q = 5 \times 10^{-10} \text{ C}$$

$$\vec{F}_m = q(\vec{v} \times \vec{B})$$

$$= 5 \times 10^{-10} \text{ coul} (6 \times 10^4 \hat{i} \frac{\text{m}}{\text{s}} \times \hat{j}B)$$

$$= 30 \times 10^{-5} B \hat{k} \frac{\text{coul.m}}{\text{s}}$$

This force directed vertically upwards balances the force of gravity on the particle at every point of motion so that it does not deviate from its path.

$$\text{Then } \vec{F}_m + m\vec{g} = 0$$

$$\Rightarrow 3 \times 10^{-5} \hat{k} B \frac{\text{coul.m}}{\text{s}} + 0.1 \times 10^{-3} \text{ kg} \times 9.8 \frac{\text{m}}{\text{s}^2} (-\hat{k}) = 0$$

$$\Rightarrow 3 \times 10^{-5} \frac{\text{coul.m}}{\text{s}} B = 10^{-4} \times 9.8 \frac{\text{kg.m}}{\text{s}^2}$$

$$\begin{aligned} \Rightarrow B &= \frac{9.8 \times 10^{-4} \text{ kg.m}}{3 \times 10^{-5} \text{ S}^2} \times \frac{\text{S}}{\text{A.S.m}} \\ &= 32.67 \frac{\text{Newton}}{\text{Amp.m}} = 32.67 \text{ Tesla} \end{aligned}$$

Ex.4: A particle having a charge of 2 nanocoulomb is accelerated through a potential difference of 1000 V where it enters a uniform magnetic field of 1 Tesla normally. Find the mass of the particle if it follows a circular path of diameter 8 cm.

Soln.

$$\text{Given } q = 2 \times 10^{-9} \text{ C,}$$

$$\text{(a) } V = 1000 \text{ V} \quad \text{(b)}$$

$$B = 1 \text{ T}$$

$$d = 8 \text{ cm}$$

$$\therefore r = 4 \text{ cm} = 0.04 \text{ m}$$

$$m = ?$$

∴ The accelerating potential is 1000 V, the K.E. of the charged particle $E_k = \frac{1}{2}m\vartheta^2$

$$= qV = 2 \times 10^{-9} \text{ C} \times 1000 \text{ V}$$

$$= 2 \times 10^{-6} \text{ J}$$

$$\Rightarrow m\vartheta^2 = 4 \times 10^{-6} \text{ J}$$

$$\Rightarrow \vartheta = \frac{2 \times 10^{-3}}{\sqrt{m}} \text{ kg}^{1/2} \frac{\text{m}}{\text{s}}$$

The magnetic force F_m on the particle

$$= B q \vartheta \sin 90^\circ$$

$$= B q \vartheta$$

Hence the centripetal force $\frac{m\vartheta^2}{r} = B q \vartheta$

$$\text{i.e. } \frac{4 \times 10^{-6} \text{ J}}{0.04 \text{ m}} = 1 \text{ T} \times 2 \times 10^{-9} \text{ C} \times \frac{2 \times 10^{-3}}{\sqrt{m}} \text{ kg}^{1/2} \text{ m/s}$$

$$\Rightarrow \sqrt{m} = \frac{1 \times 2 \times 10^{-9} \times 2 \times 10^{-3} \times 0.04 \frac{\text{A} \cdot \text{m}}{\text{A} \cdot \text{S} \cdot \text{kg}^{1/2} \cdot \text{m} \cdot \text{m}}}{4 \times 10^{-6} \frac{\text{S} \cdot \text{n} \cdot \text{m}}{\text{m}}}$$

$$\Rightarrow \sqrt{m} = 4 \times 10^{-2} \times 10^{-12} \times 10^6 \text{ kg}^{1/2} \\ = 4 \times 10^{-8} \text{ kg}^{1/2}$$

$$\therefore m = 16 \times 10^{-16} \text{ kg} = 1.6 \times 10^{-15} \text{ kg}$$

Note: In such problems $qV = \frac{1}{2}m\vartheta^2$, so that

$$\vartheta^2 = \frac{2qV}{m} \quad \dots(1)$$

$$\text{Also } B q \vartheta = \frac{m\vartheta^2}{r} \\ \Rightarrow \vartheta = \frac{Bqr}{m} \\ \Rightarrow \vartheta^2 = \frac{B^2 q^2 r^2}{m^2} \quad \dots(2)$$

From (1) and (2)

Equating eqns (1) & (2)

$$\frac{2qV}{m} = \frac{B^2 q^2 r^2}{m^2} \\ \Rightarrow m = \frac{B^2 q r^2}{2V} \quad \dots(3)$$

Substituting the values of B, q, r and V with proper units, the value of m is obtained from (3).

Ex.5: Calculate the period of revolution of a free electron moving in a plane normal to earth's magnetic field of induction of 0.6×10^{-6} Tesla.

Soln.

$$\text{Since } T = \frac{2\pi r}{\vartheta} \text{ and } e\vartheta B = \frac{m_e \vartheta^2}{r}$$

We have from the two relations

$$\frac{r}{\vartheta} = \frac{m_e}{eB}, \text{ so that } T = \frac{2\pi r m_e}{eB}$$

Given $B = 0.6 \times 10^{-6}$ Tesla. Then using standard values of m_e and e , i.e. ($m_e = 9.1 \times 10^{-31}$ kg, $e = 1.6 \times 10^{-19}$ coul), we have

$$T = \frac{2\pi \times 9.1 \times 10^{-31} \text{ kg}}{1.6 \times 10^{-19} \text{ coul} \times 0.6 \times 10^{-6} \text{ T}} = 59.6 \times 10^{-6} \text{ s}$$

Ex.6: A beam of charged particles moves undeflected when passed perpendicular to a crossed electric and magnetic field of strength 600 V/m and 1.2 T respectively. Calculate the velocity of the charged particles.

Soln.

Let the electric field be along X axis so that $\vec{E} = \hat{i}E$ and the magnetic field be along Z axis, so that $\vec{B} = \hat{k}B$.

Let the velocity of the charged particles be $\vec{v} = \hat{y}v$ (\hat{y} being unit vector along \hat{y})

The magnetic force \vec{F}_m on the charged particles of charge $q = q(\vec{v} \times \vec{B})$

The electric force \vec{F}_e on the charged particles = $q\vec{E}$

\therefore The particles remain undeflected in the crossed field

$$q\vec{E} + q(\vec{v} \times \vec{B}) = 0$$

$$\Rightarrow q\vec{E} = -q(\vec{v} \times \vec{B})$$

$$\Rightarrow \hat{i}E = -(\hat{y} \times \hat{k})vB$$

This shows that $\hat{i} = -\hat{y} \times \hat{k}$ and $v = \frac{E}{B}$ i.e.

$$-\hat{y} = \hat{j} \quad \text{and} \quad v = \frac{600 \text{ V}}{1.2 \text{ T m}} = \frac{600 \text{ J}}{1.2 \text{ C}} \cdot \frac{\text{A} \cdot \text{m}}{\text{m} \cdot \text{n}}$$

$$(\because \hat{j} \times \hat{k} = \hat{i}) \quad = 500 \text{ m/s}$$

$$\therefore \vec{v} = \hat{y}v = -\hat{j}v = -500\hat{j} \text{ m/s}$$

Ex.7: Two straight infinitely long and thin parallel wires are spaced 10 cm apart and carry a current of 10A each. Find the magnetic field at a point distant 0.1 m from both wires when the currents are in the same direction.

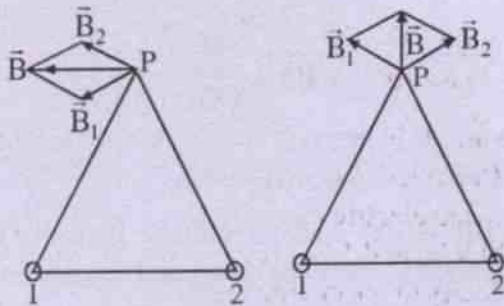

In Fig. (a) 1 and 2 represent the positions of the straight conductors remaining perpendicular to the plane of the diagram \odot . The symbol \odot denotes that the current direction in both of them is upwards. $d = 0.1 \text{ m}$ = separation between them. Point P is at distance $10 \text{ cm} = 0.1 \text{ m}$ from both 1 and 2. The magnetic fields \vec{B}_1 and \vec{B}_2 due to the two at P are shown in (a). Angle between \vec{B}_1 and $\vec{B}_2 = 60^\circ$ from the geometry of the diagram.

$$\therefore \vec{B} = \vec{B}_1 + \vec{B}_2$$

$$\text{and } |\vec{B}|^2 = |\vec{B}_1|^2 + |\vec{B}_2|^2 + 2|\vec{B}_1||\vec{B}_2|\cos 60^\circ$$

$$= 2|\vec{B}_1|^2 + 2|\vec{B}_1|^2 \cdot \frac{1}{2} = 3|\vec{B}_1|^2$$

$$\therefore |\vec{B}| = \sqrt{3}|\vec{B}_1|$$

$$\therefore |\vec{B}_1| = \frac{\mu_0 I}{2\pi d}, \text{ we have } |\vec{B}| = \sqrt{3} \frac{\mu_0 I}{2\pi d}$$

$$= \sqrt{3} \times 2 \times 10^{-7} \frac{\text{W}}{\text{A} \cdot \text{m}} \cdot \frac{10 \text{ A}}{0.1 \text{ m}}$$

$$= 3.46 \times 10^{-5} \frac{\text{W}}{\text{m}^2}$$

The direction of \vec{B} is parallel to the line joining 1 and 2. In Fig. (b) the current (1) is directed vertically upward \odot whereas current (2) is directed vertically downwards \oplus . Clearly the magnetic fields \vec{B}_1 and \vec{B}_2 due to them are as shown in Fig (b). Though $|\vec{B}_1| = |\vec{B}_2|$, the angle between them is now 120° . Then

$$|\vec{B}|^2 = |\vec{B}_1|^2 + |\vec{B}_2|^2 + 2|\vec{B}_1||\vec{B}_2|\cos 120^\circ$$

$$= 2|\vec{B}_1|^2 + 2|\vec{B}_1|^2 \left(-\frac{1}{2}\right)$$

$$= |\vec{B}_1|^2$$

$$\begin{aligned} \therefore |\vec{B}| = |\vec{B}_1| &= \frac{\mu_0 I}{2\pi d} = 2 \times 10^{-7} \frac{\text{W}}{\text{A.m}} \cdot \frac{10\text{A}}{0.1\text{m}} \\ &= 2 \times 10^{-5} \frac{\text{W}}{\text{m}^2} \end{aligned}$$

\vec{B} in this case is directed perpendicular to the line joining 1 and 2 at the midpoint in the plane of the diagram.

Ex.8: The electron in the hydrogen atom circles round the proton with a speed of 2.18×10^6 m/s in an orbit of radius 5.3×10^{-11} m. Calculate the magnetic field produced by it at the point where the proton is located. Find the current in the orbit.

Soln.

Since the electron moves round the proton and is associated with a charge, it is equivalent to a current.

$$q = |-e| = 1.6 \times 10^{-19} \text{ coul.}$$

and

$$T = \frac{2\pi r}{v} = \frac{2\pi \times 5.3 \times 10^{-11} \text{ m}}{2.18 \times 10^6 \text{ m/s}} = 15.3 \times 10^{-17} \text{ S},$$

$$\text{we have } I = \frac{q}{T} = \frac{1.6 \times 10^{-19} \text{ coul}}{15.3 \times 10^{-17} \text{ S}}$$

$$= 1.05 \times 10^{-3} \text{ A}$$

\therefore Magnetic field B at the centre of the circular path

$$\begin{aligned} &= \frac{\mu_0 I}{2r} = 2\pi \times 10^{-7} \frac{\text{W}}{\text{A.m}} \times \frac{1.05 \times 10^{-3} \text{ A}}{5.3 \times 10^{-11} \text{ m}} \\ &= 12.45 \text{ Tesla.} \end{aligned}$$

Ex.9: Two infinitely long straight conductors A and B are parallel to each other and are 50 cm apart. A and B carry currents of 6A and 4A respectively in the same direction. Find a point on the line joining the two wires where the net magnetic field due to the two wires is zero. Calculate the force per metre length of each wire.

Soln.

A and B are the points where the two wires carry currents in vertically upward directions. $AB = 0.5$ m. P is the point where the two fields due to the two wires cancel.

$$AP = x \text{ (say)}$$

$$\therefore PB = 0.5\text{m} - x$$

Then B_1 due to 1st wire at the point P

$$= \frac{\mu_0 I_1}{2\pi x}$$

and B_2 due to 2nd wire at the point P

$$= \frac{\mu_0 I_2}{2\pi(0.5\text{m} - x)}$$

$$\therefore \vec{B}_1 + \vec{B}_2 = 0 \text{ at P}$$

$$|\vec{B}_1| = -|\vec{B}_2|$$

$$\therefore \frac{\mu_0 I_1}{2\pi x} = \frac{\mu_0 I_2}{2\pi(0.5\text{m} - x)}$$

$$\Rightarrow I_1(0.5\text{m} - x) = I_2 x$$

$$\Rightarrow 6\text{A}(0.5\text{m} - x) = 4\text{A} \cdot x$$

$$\Rightarrow 3\text{m} - 6x = 4x$$

$$\Rightarrow 10x = 3\text{m}$$

$$\therefore x = 0.3\text{m}$$

The force per meter length of each wire

$$= \frac{\mu_0 I_1 I_2}{2\pi S}$$

$$= 2 \times 10^{-7} \frac{\text{W}}{\text{A.m}} \frac{6\text{A} \times 4\text{A}}{0.5\text{m}}$$

$$= 9.6 \times 10^{-6} \text{ n/m}$$

Ex.10: A flat circular coil of 10 turns lies horizontally where the horizontal component of

the earth's magnetic field has a flux density of $2 \times 10^{-5} \text{ W/m}^2$. Calculate the torque acting on the coil if it has a diameter of 20 cm and it carries a current of 0.5A.

Soln.

\therefore The plane of the coil is horizontal, it makes angle zero with the horizontal component of the earth's field

$$\therefore \theta = 0$$

Given $N = 10,$

$$I = 5 \text{ A}$$

$$B = 2 \times 10^{-5} \frac{\text{W}}{\text{m}^2}$$

and radius $r = 10 \text{ cm} = 0.1 \text{ m}$

$$\begin{aligned} \therefore |\vec{A}| &= \pi r^2 = 3.14 \times 0.01 \text{ m}^2 \\ &= 3.14 \times 10^{-2} \text{ m}^2 \end{aligned}$$

$$\begin{aligned} \therefore \text{Torque } \tau &= NI |\vec{A}| B \cos \theta \\ &= 10 \times 5 \text{ A} \times 3.14 \times 10^{-2} \text{ m}^2 \\ &\quad \times 2 \times 10^{-5} \frac{\text{W}}{\text{m}^2} \cos 0^\circ \\ &= 10^2 \times 3.14 \times 10^{-2} \times 10^{-5} \text{ mn} \\ &= 3.14 \times 10^{-5} \text{ mn.} \end{aligned}$$

Ex.11: A voltmeter reads full scale when it is connected to a power source that is maintained at a potential difference of 125 volts. When a 33,750 ohm resistor is placed in series with the voltmeter, its reading drops to 13.89 volts. Calculate the resistance of the meter.

Soln.

Let the resistance of the original meter be R_v , and let i_g be the current in it for full scale deflection θ .

$$\begin{aligned} \text{Then } \theta &\propto i_g \\ \Rightarrow \theta &= K i_g \quad \dots(1) \end{aligned}$$

$$\text{Also } i_g R_v = 125 \quad \dots(3)$$

When $R = 33,750 \Omega$ is connected in series with R_v , we have deflection $\theta' = K i_g'$ where i_g' is the new current in the meter.

$$\therefore \frac{\theta'}{\theta} = \frac{K i_g'}{K i_g} = \frac{i_g'}{i_g} \quad \dots(4)$$

$$\text{But } i_g' = \frac{125}{R_v + R}$$

$$\text{so that } i_g' (R_v + R) = 125 \quad \dots(5)$$

From (3) and (5)

$$i_g R_v = i_g' (R_v + R)$$

$$\Rightarrow \frac{i_g'}{i_g} = \frac{R_v}{R_v + R} \quad \dots(6)$$

From (4) and (6)

$$\frac{i_g'}{i_g} = \frac{\theta'}{\theta} = \frac{R_v}{R_v + R}$$

$$\Rightarrow \frac{13.89}{125} = \frac{R_v}{R_v + R}$$

$$\Rightarrow 13.89 R_v + 13.89 R = 125 R_v$$

$$\Rightarrow 13.89 R = (125 - 13.89) R_v$$

$$\Rightarrow 13.89 \times 33750 = 111.11 R_v$$

$$\Rightarrow R_v = \frac{33750 \times 13.89}{111.11}$$

$$= 4219.13 \Omega$$

$$= 4219 \text{ ohm.}$$

Ex.12: A moving coil galvanometer has a resistance of 2.5 ohm and it gives full scale deflection for a potential difference of 50 mV. If the galvanometer is converted into an ammeter with full scale deflection at 5 A, calculate the current in the coil when it reads 4A.

Soln.

$$\begin{aligned} \text{Given } G &= 2.5 \text{ ohm} \\ V &= 50 \times 10^{-3} \text{ V} = 5 \times 10^{-2} \text{ V} \end{aligned}$$

$$\begin{aligned} \therefore I_g &= \frac{V}{G} = \frac{5 \times 10^{-2} \text{ V}}{2.5 \text{ Ohm}} \\ &= 2 \times 10^{-2} \text{ A} = 0.02 \text{ A} \end{aligned}$$

Let S be the shunt connected in parallel with the galvanometer coil to convert it to ammeter of range 5A. Then

$$I = 5 \text{ A}$$

$$\therefore I_s = I - I_g = (5 - 0.02) \text{ A} = 4.98 \text{ A}$$

$$\therefore I_g G = I_s S$$

$$\begin{aligned} S &= \frac{I_g G}{I_s} = \frac{0.02 \text{ A} \times 2.5 \text{ ohm}}{4.98 \text{ A}} \\ &= 0.01 \Omega \end{aligned}$$

When the ammeter reads 4A, let the current in the coil be I'_g . Then clearly

$$I'_g G = (4 - I'_g) S$$

$$\Rightarrow 2.5 I'_g = 4 \times 0.01 - 0.01 I'_g$$

$$\Rightarrow 2.51 I'_g = 0.04$$

$$\Rightarrow I'_g = \frac{0.04}{2.51} = 0.016 \text{ A}$$

SUMMARY

A **magnetic field** is a region of space in which a moving charge experiences a force in addition to the electrostatic force of attraction or repulsion, if any, on it.

The field vector characterizing the magnetic field at any point is called **magnetic**

induction \vec{B} .

Magnetic force \vec{F}_m on a charge q moving with velocity \vec{v} in the magnetic field \vec{B} is given by

$$\vec{F}_m = q(\vec{v} \times \vec{B})$$

The magnitude of \vec{F}_m is given by $|\vec{F}_m| = q|\vec{v}||\vec{B}|\sin\theta$ where θ is the angle between increasing directions of \vec{v} and \vec{B}

The direction of \vec{F}_m is perpendicular to the plane of \vec{v} and \vec{B} and is determined by vector cross product rule.

If the region of space contains both the magnetic field and the electric field total force on a moving charge q is given by

$$\vec{F} = q\vec{E} + q(\vec{v} \times \vec{B})$$

\vec{F} is called the **Lorentz force**.

Magnetic flux (ϕ) of \vec{B} through an area \vec{A} in the magnetic field is given by $\phi = \vec{B} \cdot \vec{A} = BA \cos\theta$ where θ is the angle between \vec{B} and the direction of outwardly drawn normal to A.

Thus $B = \frac{\phi}{A \cos\theta}$ and is therefore called **magnetic flux density**.

Unit of \vec{B} is newton/Ampere. meter = $\frac{\text{n}}{\text{A.m.}}$ and called a **Tesla (T)** in S.I. system.

Unit of ϕ is $\frac{\text{newton.metre}}{\text{Ampere}} = \frac{\text{n.m}}{\text{A}}$ and it is called a **Weber (W)** in S.I. system.

1 Tesla = 1 Weber per (metre)² i.e.

$$T = \frac{W}{\text{m}^2}$$

In C.G.S. electromagnetic units, units of \vec{B} and ϕ are called **Gauss** and **Maxwell** respectively. 1 Gauss = 10^{-4} Tesla and 1 Maxwell = 10^{-8} Weber.

The magnetic field produced by a current i.e. (charges in motion) is given by **Biot-Savart**

Law, i.e. "The magnetic field $d\vec{B}$ produced by a current length element $I d\vec{\ell}$ at point P located at a distance r from the element is given by

$$d\vec{B} = \frac{\mu_0}{4\pi} \frac{I d\vec{\ell} \times \vec{r}}{r^3}$$

where \vec{r} is the position vector of P with respect to $I d\vec{\ell}$ and μ_0 is the permeability constant of free space having value

$$4\pi \times 10^{-7} \frac{\text{Tesla.metre}}{\text{Ampere}}$$

\vec{B} due to a long straight wire carrying current I at a distance s

from it is given by $\vec{B} = \frac{\mu_0 I}{2\pi s} \hat{n}$, where \hat{n} is unit vector perpendicular to the plane of the wire and s .

\vec{B} due to a **circular coil**, of radius 'a' and no. of turns N and carrying current I , at its **centre**

is given by $\vec{B} = \frac{\mu_0 NI}{2a} \hat{n}$ where \hat{n} is unit vector directed along the axis of the coil.

\vec{B} due to the same **circular coil** at any **point on its axis** and located at distance Z from

its centre is given by $\vec{B} = \frac{\mu_0 NI a^2}{2(a^2 + z^2)^{3/2}} \hat{n}$.

A **circular coil** carrying current behaves as a magnetic dipole. The dipole moment \vec{m} associated with the coil is written as $\vec{m} = NI\vec{A}$,

where $\vec{A} = \pi a^2 \hat{n}$ = the face area of a single turn of the coil and \hat{n} is unit vector associated with the area.

\vec{B} at any point on the axis of a long

solenoid carrying current I is given by

$\vec{B} = \mu_0 n I \hat{n}$ where n is the number of turns per unit length of the solenoid and \hat{n} , the unit vector along its axis.

Ampere's circuital law states that

$\oint \vec{B} \cdot d\vec{s} = \mu_0 I_{enc}$, i.e. "The tangential

component of \vec{B} summed over the elements of any closed path is equal to μ_0 times the total current across the area within the path.

Lorentz force \vec{F} on a moving charge q is the total force experienced by the charge due to the simultaneous presence of electric and magnetic field in a region of space. It is given by

$$\vec{F} = \vec{F}_e + \vec{F}_m = q\vec{E} + q(\vec{v} \times \vec{B})$$

A charged particle of charge q , mass m and moving in a uniform magnetic field \vec{B} with velocity \vec{v} , describes a circular path of radius r . The centripetal accn. of the particle is given

by $\vec{a} = \frac{q(\vec{v} \times \vec{B})}{m}$ and the radius r is given by

$$r = \frac{mv}{qB}$$

The magnetic force on a straight conductor of length ℓ and carrying current I in a magnetic field \vec{B} is given by $\vec{F}_m = I(\vec{\ell} \times \vec{B})$.

Flemings' left hand rule gives a clue to remember the direction of magnetic force on a current carrying conductor. i.e. If the thumb, the first finger and the middle finger of the left hand are kept perpendicular to one another then they point respectively the directions of magnetic force, the magnetic field and the current respectively. Two **parallel** and straight **current carrying conductors attract** each other

whereas the **antiparallel** ones **repel**. The magnitude of the force of attraction or repulsion per metre length of each conductor is given by

$$F = \frac{I_1 I_2}{2\pi S}$$

where I_1 and I_2 are the currents in the

wires and S , the separation between them.

One ampere of current is defined as that current which when maintained in two very long and straight parallel conductors separated by a metre, makes them attract each other by a force of 2×10^{-7} newton per metre.

If a loop of wire of area A carries current I and is suspended or pivoted freely in a uniform magnetic field B , it experiences a torque τ given by $\tau = NIAB \cos \theta$, where θ is the orientation of the coil with the direction of \vec{B} . Vectorially $\vec{\tau} = NIA(\hat{n} \times \vec{B})$, where \hat{n} is the direction of unit vector normal to the area A of the coil.

A **moving coil galvanometer** is a device commonly used to **detect current** in an electric circuit. It is made on the principle that a freely suspended or pivoted current carrying coil experience a torque in a magnetic field and gets deflected.

$$\text{The deflection } \theta \text{ is given by } \theta = \frac{NIBA}{C}$$

where C is the couple per unit twist of the coil.

A **galvanometer** is converted to an **ammeter** by connecting a low resistance S of suitable value in parallel with the galvanometer

$$\text{coil. } S \text{ is given by } S = \frac{G I_g}{I - I_g}$$

where G is the resistance of the galvanometer and I_g , the current in it. An ammeter is used to measure current and is connected in series with the circuit. It is a low resistance instrument.

A **galvanometer** is converted to a **voltmeter** of range V_m by connecting a high resistance R_h of suitable value in series with the galvanometer coil. R_h is given by

$$R_h = \frac{V_m}{I_g} - G$$

the symbols having their usual

meaning, given earlier. A voltmeter measures potential difference between two points in a circuit and is connected in parallel with the circuit between the points. It is a high resistance instrument.

MODEL QUESTIONS

A. Multiple Choice Type Questions :

1. The magnetic force \vec{F}_m per unit charge which moves with a velocity \vec{q} in a magnetic field \vec{B} is expressed by
 - a) $\vec{F}_m = (\vec{q} \cdot \vec{B})$
 - b) $\vec{F}_m = (\vec{q} \times \vec{B})$
 - c) $\vec{F}_m = \frac{1}{q}(\vec{q} \times \vec{B})$
 - d) $\vec{F}_m = \frac{1}{q}(\vec{q} \cdot \vec{B})$

2. The S.I. unit of magnetic flux density is called
 - a) Weber
 - b) Tesla
 - c) Maxwell
 - d) Gauss

3. (Newton.meter) per ampere is the unit of
 - a) magnetic induction
 - b) magnetic susceptibility
 - c) magnetic permeability
 - d) magnetic flux

4. The dimension of magnetic induction is written as
 - a) $M^1 L^0 T^{-2} A^{-1}$
 - b) $M^1 L^1 T^{-2} A^{-1}$
 - c) $M^1 L^2 T^{-2} A^{-1}$
 - d) $M^1 L^0 T^{-2} A^1$

5. Two conducting circular coils have radii of 5 cm and 10 cm respectively. The coil having radius 5 cm has 50 number of turns and carries a current of 2 amperes. The other one has 100 number of turns and carries a current of 0.5 ampere. The ratio of the magnetic field produced by the first coil at its centre to that produced by the second one at its centre is
 - a) 1 : 2
 - b) 1 : 1
 - c) 2 : 1
 - d) 4 : 1

6. A long straight conductor of negligible radius carries a current of 1A and is directed along Z axis. The magnetic field \vec{B} produced by it at a distance of 1m on the +Y axis is
 - a) 4×10^{-7} Tesla along + X direction
 - b) 2×10^{-7} Tesla along + X direction
 - c) 4×10^{-7} Tesla along - X direction
 - d) 2×10^{-7} Tesla along - X direction

7. A long straight solid metal wire of radius 4 mm carries a current uniformly distributed over its circular cross section. If the magnetic induction at any point on its surface is B, then the same at any point at a distance 2mm from its centre will be
 - a) $B/2$
 - b) B
 - c) 2B
 - d) 4B

8. A solenoid of radius $r = 5\text{cm}$ has a length of 2 metres. If the number of turns on the solenoid is 1000 and it carries a current of 1 ampere, the magnetic field at its midpoint is nearly
 - a) $2 \times 10^{-7} \pi$ tesla
 - b) $4 \times 10^{-7} \pi$ tesla
 - c) $4 \times 10^{-4} \pi$ tesla
 - d) $2 \times 10^{-4} \pi$ tesla

9. A charged particle having velocity \vec{v} is projected into a magnetic field \vec{B} at an angle θ with it. The path described by the particle in the field will be
- a) straight b) circular
c) helical d) elliptical
10. A charged particle of charge q and mass m moves with a velocity \vec{v} in a magnetic field \vec{B} in a circular path of radius r . If the same particle is projected with a velocity $2\vec{v}$ into a magnetic field $2\vec{B}$ in such a way that it moves in a circular path of radius r' , then
- a) $r' = r/2$ b) $r' = r$
c) $r' = 2r$ d) $r' = 4r$
11. A current carrying coil of area A is freely suspended in a magnetic field of induction B . The torque experienced by the coil is maximum when the plane of the coil makes an angle θ with the direction of \vec{B} where θ is equal to
- a) 0° b) 45°
c) 60° d) 90°
12. A coil of 100 turns carries a current of 1A and is freely suspended in a magnetic field of induction 0.5 tesla. If the face area of the coil is 0.2 m^2 , the magnetic moment associated with the coil has value
- a) 50 S.I. units b) 40 S.I. units
c) 20 S.I. units d) 10 S.I. units
13. A moving electron enters normally into a uniform magnetic field; its
- a) direction of motion will change
b) speed will increase
c) speed will decrease
d) velocity will remain the same.
14. The deflection of a galvanometer falls from 50 divisions to 20 divisions when a 12 ohm shunt is applied. Assuming the circuit resistance R to be much greater than G , the value of G is
- a) 18 ohm b) 24 ohm
c) 30 ohm d) 36 ohm
- (Orissa M.B.B.S.E.E. 1984)
15. In a magnetic field acting along X-axis, a conductor carries a current along the Y axis. The force experienced by the conductor is along
- a) the +ve Z-axis
b) the -ve Z-axis
c) the -ve X-axis
d) the -ve Y-axis
- (Orissa M.B.B.S.E.E., 1990)
16. A charge of $10 \mu \text{ coul.}$ enters a uniform magnetic field parallel to its direction. The charge will
- a) perform circular motion in a plane perpendicular to the field.
b) perform circular motion in a plane parallel to the field.
c) continue to move with acceleration.
d) move undeviated with constant velocity.
- (Orissa M.B.B.S.E.E., 1992)
17. For conversion of a Galvanometer into an ammeter, one should use
- a) a high resistance in series
b) a high resistance in parallel
c) a low resistance in series
d) a low resistance in parallel

18. A galvanometer has a resistance of 55 ohm. It gives full scale deflection for a current of 10 miliampere. To convert it to an ammeter of range one ampere, the resistance to be connected across it is
- a) 0.555Ω b) 5.55Ω
 c) 55.5Ω d) 555Ω
19. A circular coil has radius R and it carries a current so that the magnetic field produced at its centre is B . The magnetic field at a distance of $R\sqrt{3}$ from its centre on its axis is
- a) $B/2$ b) $B/3$
 c) $B/4$ d) $B/8$
20. A beam of charged particles is made to pass through a magnetic field. The work done on the beam by the field is
- a) zero
 b) dependent on the speed of the beam
 c) dependent on the deflection of the beam
 d) dependent on the value of the field.
21. Two particles X and Y have equal charges. After being accelerated through the same potential difference, both enter a region of uniform magnetic field B and describe circular paths of radii R_1 and R_2 respectively. The ratio of the mass of X to that of Y is
- a) (R_2 / R_1) b) $(R_1 / R_2)^{1/2}$
 c) (R_1 / R_2) d) $(R_1 / R_2)^2$
 (IIT, 1988)
22. The direction of force due to earth's magnetic field on a wire carrying current vertically downward is
- a) horizontally towards north
 b) horizontally towards east
 c) horizontally towards south
 d) horizontally towards west.
23. A direct current I is maintained through an infinitely long and straight thin walled tube. The magnetic induction at any point inside the tube at a distance r metres from its axis is
- a) zero b) infinite
 c) $\frac{\mu_0 I}{2r}$ d) $\frac{\mu_0 I}{2\pi r}$
24. A proton and an alpha particle enter a uniform magnetic field with the same velocity. The period of rotation of the α -particle will be
- a) four times that of the proton
 b) two times that of the proton
 c) same as that of the proton
 d) half of that of the proton
25. Two thin long parallel wires separated by a distance b are carrying a current i amp each. The magnitude of the force per unit length exerted by one wire on the other is
- a) $\frac{\mu_0 i^2}{b^2}$ b) $\frac{\mu_0 i^2}{2\pi b}$
 c) $\frac{\mu_0 i}{2\pi b}$ d) $\frac{\mu_0 i}{2\pi b^2}$
 (I.I.T.E.E. 86)
26. A conducting circular loop of radius r carries a constant current i . It is placed in a uniform magnetic field B such that B is perpendicular to the plane of the loop. The magnetic force acting on the loop is
- a) $2\pi irB$ b) πirB
 c) $i r B$ d) zero
27. The time rate of work done by a magnetic field on a charged particle moving on a helical path is
- a) qB b) qB/v
 c) $q B v^2$ d) zero

B. Very Short Type Questions :

1. Define a tesla.
2. Define a weber.
3. Draw the magnetic lines of induction due to a conductor carrying current in the upward direction.
4. Sketch a curve to show how the magnetic flux density near a straight conductor carrying current, varies with distance away from the current.
5. The number of turns and the radius of a flat circular coil carrying current are both doubled. What happens to the original magnetic field produced at its centre?
6. Write down Biot-Savart law in vector form.
7. Why are concave shaped pole pieces used in a moving coil galvanometer?
8. How is an ammeter connected in a circuit?
9. Is the resistance of a voltmeter high or low?
10. A stream of protons moves parallel to a stream of electrons. Do they tend to come closer or move apart?
11. Under what condition a charged particle moving through a magnetic field experiences no force?
12. A charged particle moves through a magnetic field in a direction perpendicular to the lines of force. Is there any change in (a) its energy? (b) its momentum?
13. Mention the use of an ammeter.
(CHSE, 1985)
14. Is the magnetic field at the centre of a current carrying circular coil parallel to its plane?
(CHSE, 1987)
15. What should be done to convert a galvanometer into an ammeter?
(CHSE, 1987, 1991)
16. Which of the following radiations are not deflected by a magnetic field? (i) α -ray, (ii) β -ray, (iii) γ -ray. (CHSE, 1988)
17. How do two parallel wires carrying current in opposite directions influence each other?
18. What is the nature of force between two parallel currents? (CHSE, 1996)
19. What is Lorentz force?
20. Under which condition is the Lorentz force on a charged particle moving in a combined electric and magnetic field zero?
21. Does the magnetic field inside a current carrying solenoid vary from point to point?
22. State Fleming's Left hand rule.
23. Define current sensitivity of a galvanometer.
24. How is radial magnetic field achieved in a moving coil galvanometer?
25. Write down the mathematical form of the magnetic moment associated with a current carrying coil. Explain the symbols.
26. Write the dimension of magnetic moment.
27. The distance between two parallel currents is reduced to half of the original value. What happens to the force between them?
28. What is the work done on a charged particle moving in a uniform magnetic field?
29. A charged particle moves in a direction that makes an angle θ with the direction of a uniform magnetic field. Mention the nature of path described by the particle?
30. Sketch the curve showing the variation of magnetic field produced by a circular current carrying coil with distance from its centre along its axis.

31. Is \vec{B} constant in magnitude for points that lie on a given line of induction ?
32. A beam of 20 Mev protons emerges from a cyclotron. Is a magnetic field associated with these particles ?
33. Sketch the curve to show how magnetic flux density near a long, straight current varies with the distance away from the current.
34. What physical quantity has the unit Wb/m^2 ? Is it a scalar or vector quantity ?
[CBSE 2004]
35. Sketch the magnetic field lines for a current carrying circular loop.
[CBSE 2007, A.I 2006]
36. The magnetic force on a moving charged particle is $\vec{F} = q(\vec{v} \times \vec{B})$. which two pairs of the vectors $\vec{F}, \vec{v}, \vec{B}$. are always perpendicular to each other ?
[CBSE 1998]
37. What will be the path of a charged particle moving along the direction of a uniform magnetic field ? [CBSE 2005]
38. Under what condition is the force acting on a charge moving through a uniform magnetic field is minimum ?
[CBSE AI 2005]
- C. Short Answer Type Questions :**
- Show that 1 tesla = 10^4 gauss.
 - Show that 1 weber = 10^8 maxwell
 - Define an 'ampere'.
 - State and explain right hand rule.
 - Explain why like currents attract.
 - A current is sent through a helical spring and it appears to be compressed. Explain.
 - Distinguish between the deflections of a charged particle in electric and magnetic fields.
 - An electron moves in a region of space but is not deflected. What type of field, electric or magnetic, may be present in the space ? Explain your answer.
 - Two long wires are hanging freely and are parallel to each other. The two are connected in series to a battery. What happens and why ?
 - The two long parallel wires are hanging freely and are connected in parallel to a battery. What happens and why ?
 - Two concentric circular loops of wire of radii r_1 and r_2 carry currents in the same direction. Explain the nature of force on the inner loop. Given $r_2 > r_1$.
 - A flexible wire is wrapped loosely around a strong magnet. Explain what will happen when a heavy current is maintained in the wire.
 - Why should an ammeter have low resistance whereas a voltmeter have high resistance ?
 - Distinguish between an ammeter and a voltmeter.
 - Explain the meaning of magnetic moment. Write down the mathematical expression of the same for a current carrying coil.
 - How is a galvanometer converted to a voltmeter ?
 - How is a galvanometer converted to an ammeter ?
 - Mention the necessity of radial magnetic field in making a galvanometer. How is it achieved ?
 - State and explain Ampere's circuital law.
 - State and explain Biot-Savart law.

21. A cable carrying a direct current is buried in a wall that stands in a north-south plane. On the west side of the wall a horizontal compass needle points south instead of north. What are (a) the position of the cable and (b) the direction of current in the cable.
22. A stream of electrons is projected horizontally towards right. A magnet brought near the electron beam produces a field directed downward. Explain what happens.
23. What sort of path will electrically charged particles follow if they are initially moving at right angles to a uniform flux density in vacuum? Will such particles experience an energy change during this motion? Explain briefly.
24. Why are magnetic fields used in many machines designed to accelerate charged particles to high energy?
25. In what respects are the actions of a galvanometer and a motor similar?
26. An ammeter and a voltmeter of suitable ranges are to be used to measure the current and voltage of an electric lamp. If a mistake were made and the meters are interchanged what will happen? Explain.
27. Plot a curve to show the variation of the torque on a coil in a magnetic field as the plane of the coil is rotated with respect to the field.
28. In electronics, wires that carry equal but opposite currents are often twisted together to reduce their magnetic effect at distance points. Why is this effective?
29. What is the basis of saying that a current loop behaves as a magnetic dipole? Explain.
30. State some of the reasons why it is a disadvantage to use a galvanometer which has too high sensitivity for the purpose in question.
31. An electron is moving along the positive X-axis in the presence of uniform magnetic field along Y-axis. What is the direction of force acting on it?
[CBSE AI 2007]
32. How will the magnetic field intensity at the centre of a circular coil carrying current change if the current through the coil is doubled and the radius of the coil is halved? [CBSE 2002]
33. Which one of the following will experience maximum force when projected with the same velocity v perpendicular to the magnetic field B . (i) α -particle and (ii) β -particle. [CBSE 2002C]
34. An ammeter and a milliammeter are converted from the same galvanometer. Out of the two which current measuring instrument has a higher resistance? [CBSE AI 2006, 2002]
35. A current is set up in a copper pipe. Is there a magnetic field (i) inside and (ii) outside the pipe? [CBSE AI 1995]
- D. Long Answer Type Questions :**
- State and explain Biot-Savart law and hence obtain an expression for the magnetic induction produced by an infinitely long straight conductor at any point near it. (CHSE, 1994)
 - Explain Biot-Savart law and apply it to obtain the magnetic induction at the centre of a circular coil carrying current. (CHSE, 1996)
 - Deduce an expression for the magnetic flux density at any point on the axis of a circular coil carrying current due to the coil.
 - A charged particle moves in a plane perpendicular to a uniform magnetic field. Show that the path of the particle is a circle. Obtain an expression for the radius of the orbit and the time period of revolution of the particle.

5. A current I is maintained in a conductor of length l which is placed in a uniform magnetic field. Find an expression for the magnetic force experienced by the conductor.
 6. Obtain an expression for the force between two straight, parallel conductors carrying currents in the same direction. Hence obtain the definition of an 'ampere'.
 7. Explain Lorentz force experienced by a moving charged particle. Find the condition under which the Lorentz force on a charged particle moving in a combined electric and magnetic field is zero.
 8. Show that a current carrying loop is equivalent to a magnet. Obtain an expression for the magnetic moment of the loop in terms of the loop parameters.
 9. Obtain an expression for the magnetic force between two moving charged particles. Compare it with the electrostatic force between two charges when these are static.
 10. Obtain an expression for the torque experienced by a freely suspended current carrying loop in a uniform magnetic field. Mention the factors on which the torque depends.
 11. Give the principle of construction and working of a moving coil galvanometer. Can a galvanometer be used to measure current? Explain your answer.
 12. Describe the construction and working of an ammeter. How is an ammeter connected in a circuit and why?
 13. Describe the construction and working of a voltmeter. How is a voltmeter connected in a circuit? Explain.
 14. Give the principle of construction and working of an ammeter. How is its range changed? Explain with necessary mathematical equations.
 15. Discuss how a moving coil galvanometer is converted into a voltmeter of different ranges.
 16. Give the principle of construction of a dead beat type galvanometer. Explain galvanometer sensitivity.
 17. A beam of +vely charged particles moves vertically upwards and another beam of -vely charged particles moves vertically downwards. Do the two beams attract or repel. Explain with necessary mathematical equations.
 18. "Helmholtz coils" consist of two large, flat, circular coils mounted with a common axis and at a distance apart equal to their common radius. Show that this arrangement produces a uniform magnetic flux density over a small space midway between the coils. Derive an equation for this flux density when the coils have the same currents in the directions to produce additive effects.
 19. Derive the formula that gives the resistance necessary to increase N -fold the range of a voltmeter. Obtain similar formula for the resistance of the shunt required to increase N -fold the range of an ammeter.
 20. A tangent galvanometer consists of a flat circular coil of a few turns N and radius r . The coil is placed with its plane parallel to the horizontal component of the earth's magnetic field of flux density \bar{B} . A small compass needle mounted at the centre of the coil is deflected through θ when there is a current I in the coil. Show that $\frac{\mu_0 NI}{2r} = B \tan \theta$.
- E. Numerical Problems :**
1. Calculate the magnetic induction at the centre of a flat circular coil of 100 turns

- of wire and 1.52 cm radius that carries a current of 6.28 A. Show by a sketch the direction of this field.
2. A flat circular coil of 120 turns has a radius of 18cm and carries a current of 3 amperes. Find the magnitude and direction of the flux density at a point on the axis of the coil at a distance from the centre equal to the radius of the coil.
 3. An alpha particle describes a circle of radius 0.49 m in a uniform magnetic field of induction 0.6 Tesla. Assuming that the velocity of the particle is perpendicular to the field, calculate its speed and kinetic energy. ($m_p = 1.67 \times 10^{-27}$ kg)
 4. The electron in the hydrogen atom circles round the proton with a speed of 2.18×10^6 m/s in an orbit of radius 5.3×10^{-11} m. Calculate the magnitude of the magnetic field produced by it at the nucleus and find its frequency and the current in the orbit.
 5. Copper has 8×10^{28} conduction electrons per cubic meter. A one metre long copper wire having 8×10^{-6} m² cross sectional area carries a current in it and lies at right angle to a magnetic field of strength 0.05 tesla. If the force on the wire is 0.8 newton, find the drift speed of free electrons in the wire.
 6. A horizontal wire of length 0.1 m carries a current of 5A. Calculate the magnitude and direction of the magnetic field which can support the weight of the wire. Assume that the mass per metre length of the wire is 3×10^{-3} kg.
 7. Two long parallel wires each carrying a current of 10A and separated by 4 cm, lie in a vertical plane. Find the magnitude and direction of the magnetic field at a point lying at 4 cm to the left of the first wire on the line joining the two wires in a horizontal plane.
 8. Two long wires each carrying a current of 0.5A are directed along x and y axes respectively. If the wires are well insulated from each other and intersect at a point O in the xy plane, find the magnitude and direction of the force on a length element of 0.2 cm of the wire lying along x axis, the element being at a distance of 10 cm from O.
 9. A long vertical wire carrying a current of 10A in the upward direction is placed in a region where a horizontal magnetic field of 2×10^{-3} tesla exists from south to north. Locate the point where the resultant magnetic field is zero.
 10. An electron makes 3×10^5 revolutions per second in a circle of radius 0.5 angstrom. Find the magnetic field B at the centre of the circle.
 11. A semi circular wire of radius 10 cm carries a current of 5 amperes. Calculate the magnetic field due to it at the centre of the circle.
 12. A long cylindrical wire of radius 2.5 mm carries a current of 1A distributed uniformly over its cross section. Find the magnitude of the magnetic field at a point inside the wire at a distance of 1mm from the axis.
 13. A long solenoid has closely wound turns such that the successive turns nearly touch each other but are well insulated. If the wire used in the solenoid has a radius of 0.5 mm find the magnetic field at the centre of the solenoid when it carries a current of 5A.
 14. A magnetic field of $4 \times 10^{-3} \hat{k}$ tesla exerts a force of $(4\hat{i} + 3\hat{j}) \times 10^{-10}$ newton on a particle having a charge of 10^{-9} coulomb in the XY plane. Find the velocity of the particle.

15. A rectangular coil of 100 turns and of length 5 cm and width 4 cm is suspended in a uniform magnetic field with its plane parallel to the field. A torque of 0.2 m.n acts on the coil when a current of 0.2A is maintained in it. Find the magnitude of the magnetic field.
16. A moving coil galvanometer has a resistance of, 30 ohms through which a current of 1 mA flows. Find the value of the multiplier resistance to be used with the galvanometer to convert it to a voltmeter of range (a) 2.5 volts, (b) 10 volts.
17. A rigidly supported long horizontal wire carries a current I_a of 100 A. Directly above it and parallel to it is a fine wire that carries a current I_b of 20A and weighs 0.073 n/m. How far above the lower wire should this second wire be strung so that it may be supported by magnetic repulsion? (Assume the diameter of the wires to be small).
18. Two parallel wires separated by 2m carry currents of 3A each in opposite directions. Find the magnetic induction for points between the wires and at a distance 50cm from each wire.
19. In the Bohr model of hydrogen atom the electron circulates around the nucleus in a path of radius 5.1×10^{-11} m at a frequency of 6.8×10^{15} rev/Sec. Find the magnetic induction at the centre of the orbit. Calculate the equivalent magnetic dipole moment.
20. A straight wire segment of length ℓ carries a current I . Show that the field of induction \vec{B} due to it at a distance R from the segment along a perpendicular bisector is given in magnitude by

$$B = \frac{\mu_0 I}{2\pi R} \frac{\ell}{(\ell^2 + 4R^2)^{3/2}}$$

Calculate the same for $I = 1A$, $\ell = 1m$ and $R = 1m$.

21. A 25 turn rectangular coil 12 by 15 cm is placed with its plane parallel to a flux density of 0.004 W/m^2 . Calculate the torque produced in it for current of 400 mA when the 12 cm side is parallel to the flux density. Will the torque be different if the same side is perpendicular to the flux density?
22. A 50 mili voltmeter has a resistance of 5 ohms. A multiplier has been inserted to produce a voltmeter of range 3 volts. How can multiplier be modified so that the new meter will have a range of 15 volts?
23. A galvanometer of resistance 12 ohm gives full scale deflection for a current of 2.5 mA. How will you convert it to an ammeter of range 7.5A. Find the resistance of the ammeter.
24. A portable galvanometer gives full scale deflection for a current of 1 mA. With a resistance of 9900 ohm in series with its coil it can measure potential diff. upto 10 volts. Find the resistance of the galvanometer. How can you convert it to an ammeter of 10 mA range?
25. A galvanometer of resistance 50Ω produces full scale deflection by a current of 0.15A. Determine the value of the shunt required to make it an ammeter of range (i) 1.5 A and (ii) 5A.
26. A uniform magnetic field \vec{B} of magnitude 1.2 mT points vertically upward throughout the volume of a laboratory chamber. A proton with kinetic energy 5.3 Mev enters the chamber moving horizontally from south to north. Find the magnetic deflecting force acting on the proton as it enters the chamber. What acceleration is produced in the proton? The proton mass is 1.67×10^{-27} kg.
27. A Helmholtz coil consists of two thin, flat co-axial coils separated by a distance equal to half the radius of each coil. Compare the magnetic field induction at the centre of each coil with that produced at the mid point of the axis and show that inside the Helmholtz coil the field is almost uniform.

28. Find the magnetic field at the centre of a square of side 'a' carrying current I amp. [CBSE 1994]
29. A semi circular arc of radius 20 cm carries a current of 10 A. calculate the magnetic field at the centre of the arc. [CBSE 2002]
30. Two small identical circular loops, marked (1) and (2), carrying equal currents, are placed with the geometrical axes perpendicular to each other as shown in the figure. Find the magnitude and direction of the magnetic field produced at the point O. [CBSE2008, 05]

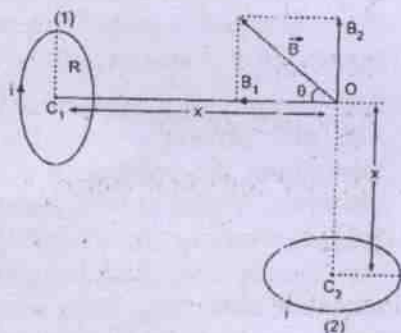
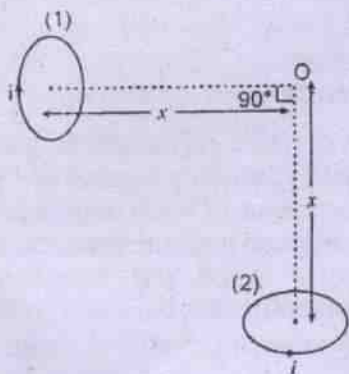

F. Answer as directed:

- Is there any change in the energy of a charged particle moving in a magnetic field although a force is acting on it?
- An electron is travelling horizontally towards west. A magnetic field acts in vertically downward direction. The force

on the on the electron is in the direction of _____.

- The torque acting on current carrying coil is zero if the plane of the coil is _____ to the lines of induction.
- Will a voltmeter be damaged, if it is connected in series to an electric circuit? (Yes/No)
- A voltmeter always gives lower value of P.D. why?
- For a moving coil galvanometer, when the current through the coil will be directly proportional to its deflection?
- Two charges q_1 and q_2 move with equal speeds v parallel to each other. What is the ratio of the magnetic and electrical forces between them?
- If a long copper rod carries a direct current, the magnetic field associated with the current will be both inside and outside the rod-(True/False)
- What is the unit pole-strength?
- A neutron enters a magnetic field of strength B (tesla), perpendicular to the magnetic lines of force, with speed v . What is the force on the neutron?

G. Correct the following sentences:

- S.I unit of magnetic lines of force is Maxwell.
- 1 weber = 10^{-8} maxwell.
- 1 tesla = 10^6 gauss.
- The magnetic field at the centre of a circular coil of radius a, carrying current I, is given as $B = \mu_0 I / 4\pi a$.
- The magnetic field due to an infinitely long straight current is given as $B = \mu_0 I / 4\pi d$.
- Fleming's right hand rule gives the direction of magnetic force on the conductor due to a current.
- A galvanometer is converted to an ammeter by connecting a suitable small resistance in series with it.

ANSWERS

A. Multiple Choice Type Questions :

1. (b) 2. (b) 3. (d) 4. (a) 5. (d) 6. (d) 7. (a) 8. (d)
 9. (c) 10. (b) 11. (a) 12. (c) 13. (a) 14. (a) 15. (b) 16. (d)
 17. (d) 18. (a) 19. (d) 20. (a) 21. (d) 22. (b) 23. (a) 24. (b)
 25. (b) 26. (d) 27. (d)

E. Numerical Problems :

1. 0.026 Tesla. Dirn. is along the axis of the coil.
2. $B = 4.4 \times 10^{-4}$ Weber / m^2 , Dirn. is along the axis of the coil.
3. $v = 1.4 \times 10^7$ m/s, $E_k = 6.54 \times 10^{-13}$ J
4. $B = 12.4$ T, $f = 6.5 \times 10^{15}$ Hz, $I = 1.05 \times 10^{-3}$ A
5. 1.56×10^{-4} m/s
6. $|\vec{B}| = 5.88 \times 10^{-3}$ T, If dirn. of charge flow is from West to East the direction of \vec{B} is from South to North in the horizontal plane.
7. $\vec{B} = 0.375 \times 10^{-4} (-\hat{j})$ Tesla if line joining 1 to 2 is along \hat{i}
8. 5×10^{-7} n along y direction
9. 1 mm west to the wire.
10. 6×10^{-10} T
11. 1.6×10^{-5} T
12. 3.2×10^{-5} T
13. $2\pi \times 10^{-3}$ T
14. $(-75\hat{i} + 100\hat{j})$ m/s
15. 0.5 T
16. (a) 2470 ohms, (b) 9970 ohm
17. 5.5 mm
18. 7×10^{-7} W/ m^2 in each case
19. 14 W/ m^2 , 9×10^{-24} Am²
20. 9×10^{-8} T nearly
21. 7.2×10^{-4} mn, No.
22. By adding 1.2×10^3 ohm in series with the original coil of the meter.
23. Resistant of shunt 4×10^{-3} ohm, $R_A = 4 \times 10^{-3} \Omega$
24. $G = 100 \Omega$, By connecting a shunt of resistance 0.09 ohm.
25. (i) 5.5 ohm (ii) 1.55 Ω
26. $f_m = 6.1 \times 10^{-15}$ newton $a = 3.7 \times 10^{12}$ m/S²
27. $B_1 = \frac{\mu_0 n I}{2a} (1.7155)$ $B_2 = 0.9130 \frac{\mu_0 n I}{a}$, $\frac{B_2}{B_1} = 1.0644$
28. $2\sqrt{2}\mu_0 I / \pi a$, 29. 1.57×10^{-5} T, 30. $B = (\mu_0 / 4\pi) (2\sqrt{2}\mu_0 i A / x^3)$

- F. (1) No change (2) North (3) Perpendicular (4) No. (5) (It takes some current for its own deflection (6) The magnetic field should be radial (7) $7^2/c^2$ (8) True (9) amp-m. (10) zero